



TOHNICHI

Professional Torque Product Catalogue

2015

Your Torque Partner

Through advances in torque technology, Tohnichi contributes to the creation of a safer world by helping to obtain the highest level of product safety in transportation, information technology, and many other fields that affect our daily lives.

TORQUE CENTER

A wide variety of services available including: theoretical information, application assistance, training seminars, and testing facilities.

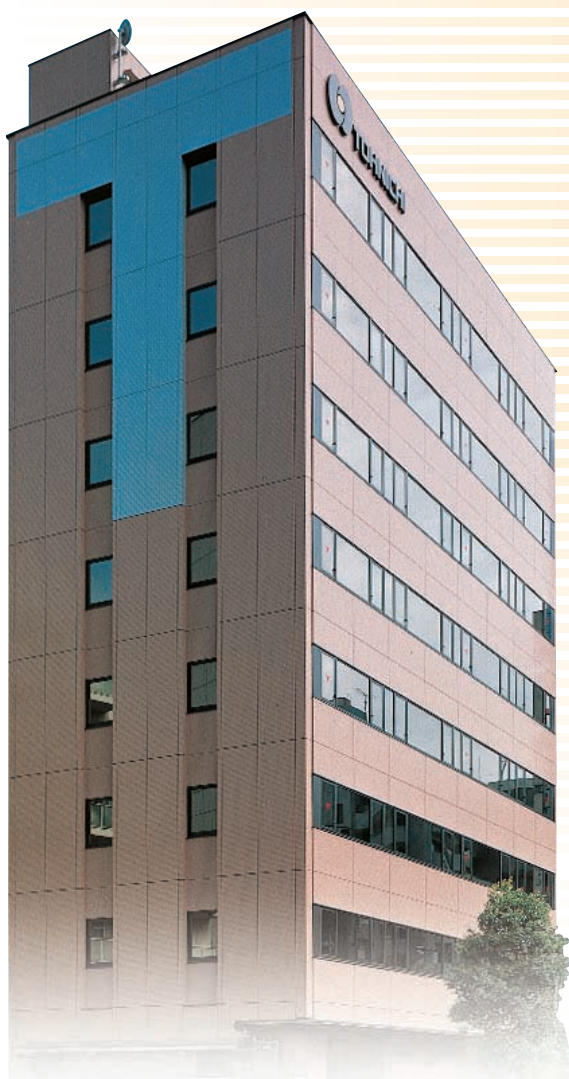

Tohnichi Torque Center in Tokyo

Laboratory

Visitors can use this space. Actual work piece is carried in and proper tightening torque can be measured.



Showroom

Tohnichi torque products are set-up and displayed so that visitor can have a clear look on what is available on the torque market and what will be coming up soon.

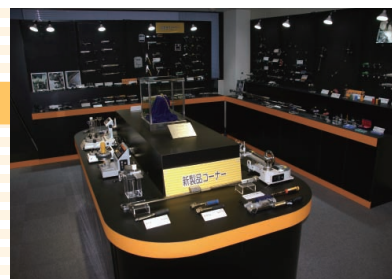

Lecture room

Various courses of torque engineering seminars are available.



Training room

Our customers can attend workshops, covering a global training, general repair and adjustment on torque products.



The above facilities and services are available at Tokyo, Osaka, Nagoya in Japan, Tohnichi Shanghai in China, Tohnichi Europe in Belgium, and Tohnichi America in Chicago.

Contents

How to Select Torque Products (by Model)	2
From Torque Control to Tightening Assurance System	4

Torque Screwdriver

RTD	Rotary Slip Adjustable Torque Screwdriver	6
LTD	Adjustable Torque Screwdriver	6
RTDLS/RNTDLS	Rotary Slip type Torque Screwdriver with Limit Switch	6
RNTD	Rotary Slip Preset Torque Screwdriver	7
NTD	Preset Torque Screwdriver	7
RTDZ/RNTDZ	Rotary Slip Adjustable/Preset Insulated Torque Screwdriver	7
AMRD/BMRD	Rotary Slip Adjustable Torque Screwdriver for Small Screws	8
AMLD/BMLD	Adjustable Torque Screwdriver for Small Screws	8
FTD	Dial Indicating Torque Screwdriver with Memory Pointer	9
MTD	Micro Dial Indicating Torque Screwdriver	9
STC2-G/STC2-G-BT	Digital Torque Screwdriver	10
Interchangeable Bit		11

Torque Wrench for Assembly

QL/QLE2	Ratchet Head Type Adjustable Torque Wrench	12
QL-MH	Ratchet Head Type Adjustable Torque Wrench with Metal Handle	12
CL/CLE2	Interchangeable Head Type Adjustable Torque Wrench	13
CL-MH	Interchangeable Head Type Adjustable Torque Wrench with Metal Handle	13
DQL/DQLE2	Dual Square Drives Type Adjustable Torque Wrench	14
MTQL	Torque Wrench for Motorsports	14
MT70N	Moto Tork (Pre-Lock Adjustable Specialty Torque Wrench)	14
TiQL/TiQLE	Titanium Type Adjustable Torque Wrench	15
PHL/PHLE2	Pipe-Wrench Head Type Adjustable Torque Wrench	15
QRSP	Open Ring Head Type Preset Torque Wrench	15
PQL	Ratchet Head Type Pre-Lock Torque Wrench	16
PQLZ	Pre-Lock Adjustable Insulated Torque Wrench	16
QSPZ	Preset Insulated Torque Wrench	16
PCL	Interchangeable Head Type Pre-Lock Torque Wrench	17
SCL	European Style Interchangeable Head Type Adjustable Torque Wrench	17
SCSP	European Style Interchangeable Head Type Preset Torque Wrench	17
QSP	Ratchet Head Type Preset Torque Wrench	18
QSP-MH	Ratchet Head Type Preset Torque Wrench with Metal Handle	18
BQSP5	Bi-Directional Type Preset Torque Wrench	18
CSP	Interchangeable Head Type Preset Torque Wrench	19
CSP-MH	Interchangeable Head Type Preset Torque Wrench with Metal Handle	19
BCSP5	Bi-Directional Interchangeable Head Type Preset Torque Wrench	19
SP-SP2/-MH	Open End Head Type Preset Torque Wrench	20
RSP-RSP2/-MH	Ring Head Type Preset Torque Wrench	20
SP-H	Torque Wrench for Piping Work	21
SP-N/SP-N-MH	Notched Head Type Preset Torque Wrench	21
NSP100CNx8	Break-Over Torque Wrench	21
QSPCA	Slip Type Torque Wrench	22
YCL2	Two Step Motion Torque Wrench	22
CPT-G	PRO TORK (Digital Torque Wrench for Tightening)	23
CTA2	Digital Torque and Angle Wrench	24
DWQL	Analog Torque with Digital Angle Module	25
WQL	Analog Torque and Angle Wrench	25
MPQL/MQL	Marking Torque Wrench	26
MQSP	Marking Torque Wrench	26
CMQSP	Marking Torque Wrench	26
MPQL/MQL/MQSP Optional Accessories		27
Pokayoke, Error-Proofing System		28
Torque Wrench with Limit Switch		29
FH256MC	Radio Frequency Torque Wrench System	30
FMA	Radio Frequency Torque Wrench System (USA)	31
CNA-4mk3	POKA Patrol (Count Checker)	31
Tightening Data Management System		32

Torque Wrench for Quality Inspection

CEM3-G	DATA TORK (Digital Torque Wrench)	36
CTB2-G	Digital Retightening Torque Wrench	37

DB/DBE/DBR	Dial Indicating Torque Wrench	38
CDB-S	Interchangeable Head Type Dial Indicating Torque Wrench	39
SCDB-S	European Style Interchangeable Head Type Dial Indicating Torque Wrench	39
T-S	T-Handle Dial Indicating Torque Wrench	39
SF/F/FR	Beam Type Torque Wrench	40
CSF/CF	Interchangeable Head Type Beam Type Torque Wrench	40
QF/QFR	Ratchet Head Beam Type Torque Wrench	40
Interchangeable Socket		41

Accessories

Interchangeable Head	42
Auxiliary Equipment	46
Connecting Cable	47
Quick Charger, Battery Pack, AC Adapter	47

Power Torque Tools

AUR	UNITORK (Pistol Type Pneumatic Torque Screwdriver)	48
HAT	HANDYTORK (Battery Operated Torque Screwdriver)	48
U/UR	UNITORK (Straight & Pistol Pneumatic Torque Screwdriver)	49
A/AC	Semi-Automatic Airtork	50
AS	Fully-Automatic Airtork	50
AP	Fully-Automatic Airtork	51
DAP	Fully-Automatic Electric Torque Wrench	51
ME/MC	Multiple Unit (Pneumatic Straight Style)	52
MG/MF	Multiple Unit (Pneumatic Straight Style)	52
AME	Multiple Unit (Pneumatic Right Angle Style)	52
DCME	Multiple Unit (Electric Straight Style)	53

Torque Tester/Checker

DOTE3-G	Digital Torque Wrench Tester	54
DOT	Analog Torque Wrench Tester	54
TF	Fully Automatic Digital Torque Wrench Tester	55
TCC2-G	Digital Torque Wrench Tester	55
LC3-G	Torque Wrench Line Checker	56
ST3-G/ST3-G-BT	SPINTORK (Rotary Peak Torque Meter)	56
TDT3-G	Digital Torque Screwdriver Tester	57
ATG/BTG	Analog Torque Gauge	58
ATGE-G	Digital Torque Gauge	58
BTGE-G	Digital Torque Gauge	59
TME2	Digital Torque Meter	60
TM	Analog Torque Meter	60
TCF	Fixed Type Torque Sensor	61
TCR	Rotary Type Torque Sensor	61
Calibration Kit		62

Force Measurement Instrument

BTM/B-BTM	Bolt Tension Meter	63
Fcon	Bolt Tension Stabilization	63
TT2000	Ultrasonic Tension Meter	64
FP	Force Pen	65
FG	Force Grip	65

Optional Equipment

CD5	Compact Display	66
R-DT999	Data Tank	66
DFS	Data Filing System (CD-ROM)	66
EPP16M3	Printer	67
DECA	10:1 Ratio Torque Multiplier	67
EVERTORQUE	Lubricant for repairing torque products	67

Technical Data

Torque Settings for Torque Screwdrivers	68
Torque Settings for Torque Wrenches	69
Torque Conversion List	70
Standard Tightening Torque	71
Tohnichi's Worldwide Services System	72

How to Select Torque Products (by Model)

Select the correct Tohnichi product for an application.

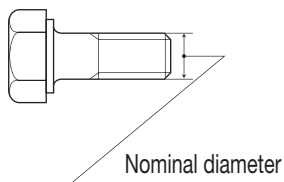

TORQUE PRODUCTS

TORQUE WRENCH

Nominal diameter
M4-M40

FOR TIGHTENING

Tightening bolts at a given torque

QL

Standard model for tightening

P.12

FOR INSPECTION

Inspecting the torque of tightened bolts

DB/CDB

Standard model for inspection

P.38

TORQUE SCREWDRIVER

Nominal diameter
M1.6-M6

FOR TIGHTENING

Tightening screws at a given torque

RTD/LTD/AMRD/AML

Rotary slip torque screwdriver
(Over-torque prevention)

P.6

FOR INSPECTION

Inspecting the torque of tightened screws

FTD-S/FTD

Direct reading type

P.9

TORQUE GAUGE/ TORQUE METER

Measuring torque for
special products

FOR MEASURING VERY SMALL TORQUE

Inspecting small torque ranging
from 0.05cN-m-150cN-m

ATG/BTG
with 3-jaw chuck

P.58

FOR MEASURING CAP OPENING TORQUE

For checking torque on bottle caps,
starting torque test, and twisting torque, etc.

TM

Analog type

P.60

If other types of head is requested

CL



Interchangeable head version of QL P.13

In such working condition where resin handles are not suitable

QL-MH



Metal handle version of QL P.12

CL-MH



Metal handle version of CL P.13

If tightening at one particular torque only

QSP



Preset version of QL P.18

CSP



Interchangeable head version of QSP P.19

If tightening the same bolts at particular torque only

SP



Preset type open end head P.20

SP-MH



RSP



Preset type ring head P.20

RSP2-MH



SF/F/QF/CF



Beam type P.40

CEM3-G/CTB2-G



Digital type P.36

For calibrating torque wrenches



TCC2-G

P.55



DOTÉ3-G

P.54

Tightening at one particular torque only

RNTD/NTD



Preset version of RTD P.7

STC2-G



Digital type P.10

For daily inspection of torque wrenches



LC3-G Line Checker P.56



Other Torque Wrench Testers:
DOT and TF models are also available.

Other Torque Measurement

ST3-G/TCF/TCR

P.56

P.61

ATGE-G



Digital type P.58

BTGE-G



Digital type P.59

TME2



Digital type P.60

Example

CL 100 N × 15D

Size of interchangeable head
* Interchangeable head type only

Unit (N = N-m, CN = cN-m, MN = mN-m)

Torque range (Maximum torque in S.I. unit)

Model

Please refer to the **"Torque Handbook vol. 8"** for further technical information.

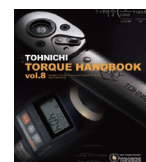

From Torque Control to Tightening Assurance System

Tohnichi's Torque Assurance System advises the users how to tighten bolts properly and how to eliminate various mistakes which occur during bolt tightening operations.

Total Tightening Management System, which completes tightening assurance, will be created through cooperation of your staffs. Each component and product which consists of the system can be sold separately. The components and products are described in the catalog.

TOHNICHI TIGHTENING ASSURANCE SYSTEM

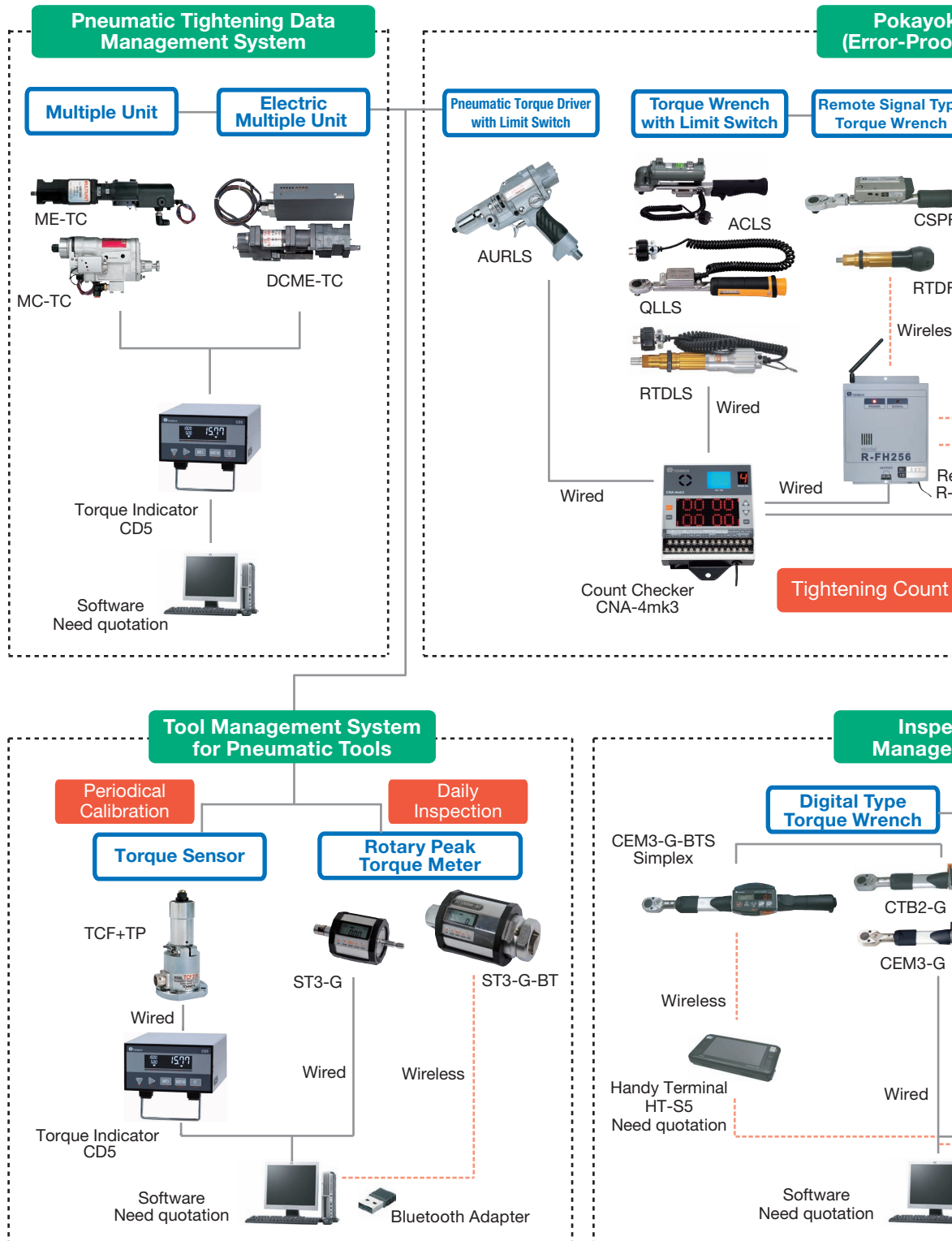

Characteristic factors (4M's) of defects in bolt tightening

- | | |
|--|---|
| <p>1. MAN (Tightening operator human error)</p> <ul style="list-style-type: none"> · Missed tightening · Improper tightening tool usage <p>2. METHOD (Improper tightening specification)</p> <ul style="list-style-type: none"> · Wrong tightening value specification · Wrong tightening procedure · Wrong tightening tool selection | <p>3. MACHINE (Improper tightening equipment)</p> <ul style="list-style-type: none"> · Inaccuracy · Mechanical failure <p>4. MATERIAL (Improper screw joint material)</p> <ul style="list-style-type: none"> · Part out of tolerance · Defective part material · Insufficient screw part lubricant |
|--|---|

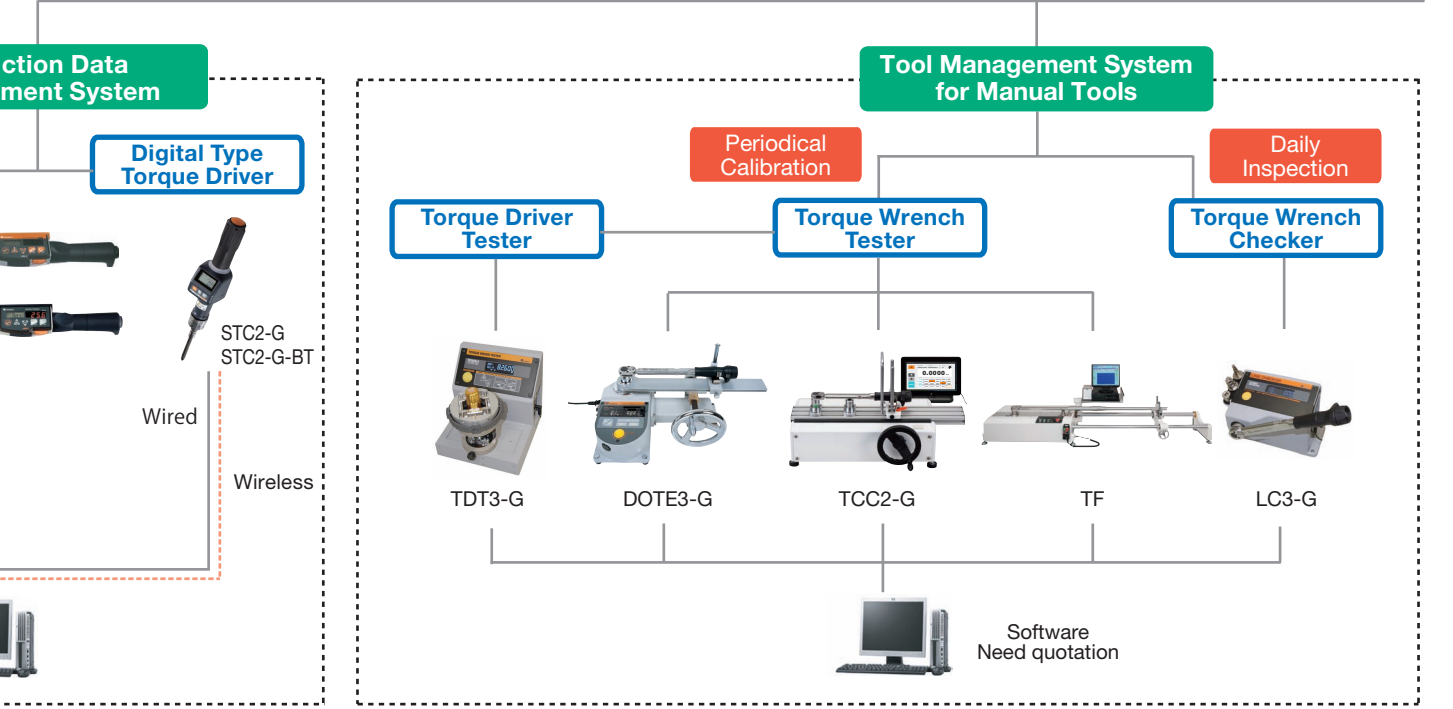
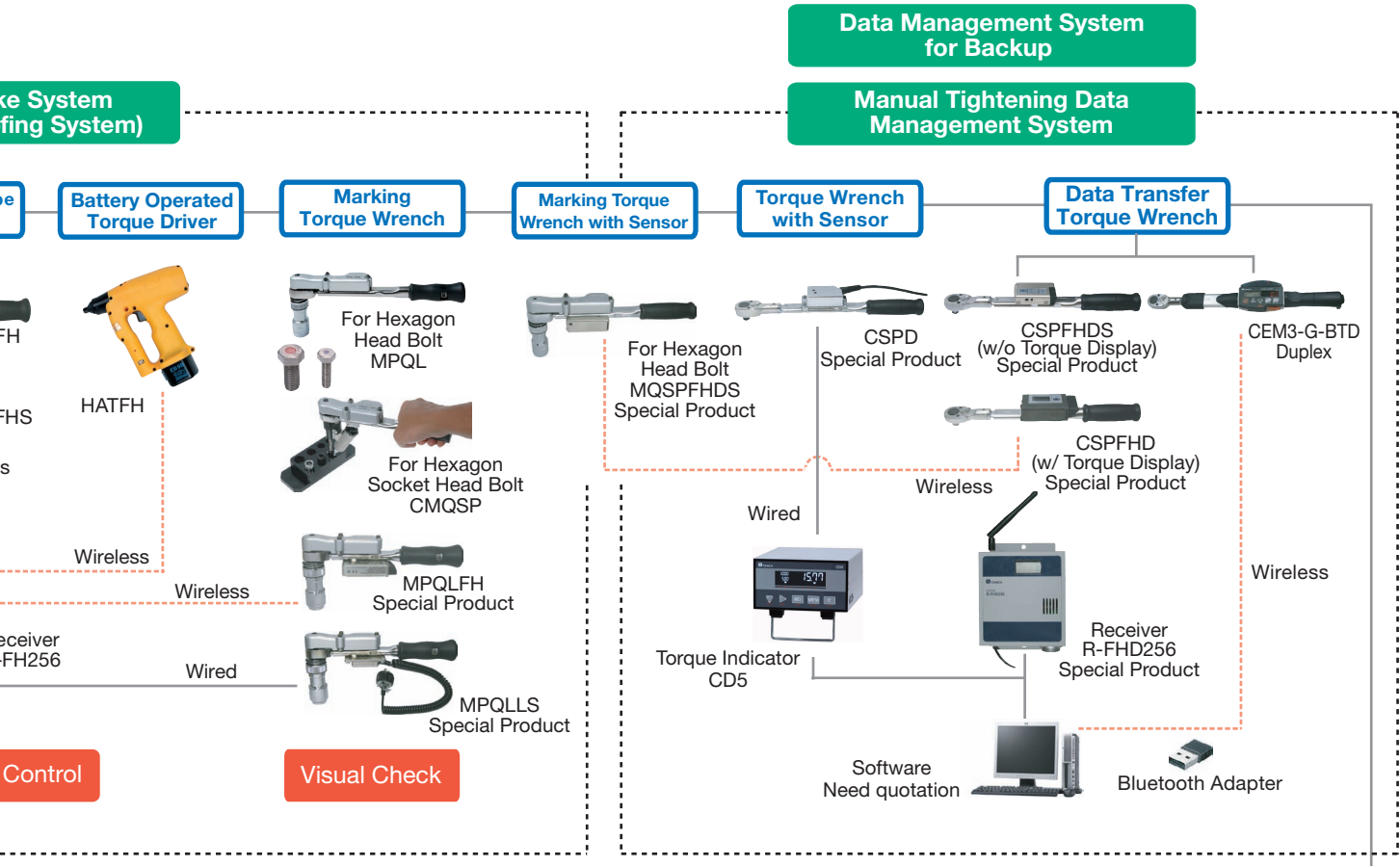

RTDRotary Slip Adjustable
Torque Screwdriver

Assembly

Adjustable

Rotary Slip

Graduation

RoHS

Direction



RTD60CN



RTD120CN (with Resin Grip)

- Ratcheting mechanism prevents over torque.
- Torque value easily set with external scale

Accuracy ±3%

S.I. Model	Torque Range [cN·m]		Metric Model	Torque Range [kgf·cm]		American Model	Torque Range [ozf·in/lbf·in]		Overall Length [mm]	Weight [g]
	Min.-Max.	Grad.		Min.-Max.	Grad.		Min.-Max.	Grad.		
-	-	-	-	-	-	RTD20Z	6-20	0.2	100	50
-	-	-	-	-	-	RTD40Z	15-40	0.5	-	-
-	-	-	-	-	-	RTD80Z	20-80	1	110	80
-	-	-	-	-	-	RTD150Z	30-150	2	130	160
RTD15CN	2-15	0.1	1.5RTD	0.2-1.5	0.01	RTD1.3I	0.2-1.3	0.01	100	50
RTD30CN	4-30	0.2	3RTD	0.4-3	0.02	RTD2.6I	0.4-2.6	0.02	-	-
RTD60CN	10-60	0.5	6RTD	1-6	0.05	RTD5I	1-5	0.05	110	80
RTD120CN	20-120	1	12RTD	2-12	0.1	RTD10I	2-10	0.1	130	160
RTD260CN	60-260	2	26RTD	6-26	0.2	RTD22I	6-22	0.2	150	270
RTD500CN	100-500	5	50RTD	10-50	0.5	RTD40I	10-40	0.5	155	320

Note

1. Auxiliary tightening tool for RTD500CN is available, sold separately.
2. Bits are sold separately. Refer to page 11.

Standard Accessories

1. Preset hook spanner (for RTD260CN and RTD500CN only)
2. Resin grip (for RTD120CN and RTD260CN only)

LTDAdjustable Torque
Screwdriver

Assembly

Adjustable

Graduation

RoHS

Direction



LTD60CN



LTD120CN (with Resin Grip)

- Clicks at set torque value
- Torque value easily set with external scale

Accuracy ±3%

S.I. Model	Torque Range [cN·m]		Metric Model	Torque Range [kgf·cm]		American Model	Torque Range [ozf·in/lbf·in]		Overall Length [mm]	Weight [g]
	Min.-Max.	Grad.		Min.-Max.	Grad.		Min.-Max.	Grad.		
-	-	-	-	-	-	LTD20Z	6-20	0.2	100	50
-	-	-	-	-	-	LTD40Z	15-40	0.5	-	-
-	-	-	-	-	-	LTD80Z	20-80	1	110	80
-	-	-	-	-	-	LTD150Z	30-150	2	130	160
LTD15CN	2-15	0.1	1.5LTD	0.2-1.5	0.01	LTD1.3I	0.2-1.3	0.01	100	50
LTD30CN	4-30	0.2	3LTD	0.4-3	0.02	LTD2.6I	0.4-2.6	0.02	-	-
LTD60CN	10-60	0.5	6LTD	1-6	0.05	LTD5I	1-5	0.05	110	80
LTD120CN	20-120	1	12LTD	2-12	0.1	LTD10I	2-10	0.1	130	160
LTD260CN	60-260	2	26LTD	6-26	0.2	LTD22I	6-22	0.2	150	270
LTD500CN	100-500	5	50LTD	10-50	0.5	LTD40I	10-40	0.5	155	320
LTD1000CN	200-1000	5	100LTD	20-100	0.5	LTD90I	20-90	0.5	185	580
LTD2000CN	300-2000	5	200LTD	30-200	0.5	LTD180I	30-180	0.5	255	1150

Note

1. Auxiliary tightening tool for LTD500CN and LTD1000CN is available, sold separately.
2. Bits are sold separately. Refer to page 11.
3. Bits for LTD2000CN are supplied from only Tohnichi.

Standard Accessories

1. Preset hook spanner (for LTD260CN-LTD2000CN only)
2. LTD2000CN comes with an auxiliary tightening tool.
3. Resin grip (for LTD120CN and LTD260CN only)

RTDLS/RNTDLS

Assembly

RoHS

Direction

Rotary Slip type Torque
Screwdriver with Limit
Switch

RTDLS



RNTDLS

- RTD/RNTD style with Limit Switch output
- Ideal for torque verification (Pokayoke) assembly processes

Accuracy ±3%

S.I. Model	Torque Range [cN·m]		Metric Model	Torque Range [kgf·cm]		American Model	Torque Range [lbf·in]		Overall Length [mm]	Weight [g]
	Min.-Max.	Grad.		Min.-Max.	Grad.		Min.-Max.	Grad.		
RTDLS120CN	20-120	1	12RTDLS	2-12	0.1	RTDLS10I	2-10	0.1	184	340
RTDLS260CN	60-260	2	26RTDLS	6-26	0.2	RTDLS22I	6-22	0.2	201	450
RTDLS500CN	100-500	5	50RTDLS	10-50	0.5	RTDLS40I	10-40	0.5	212	540
RNTDLS120CN	40-120	-	-	4-12	-	-	4-10	-	166	320
RNTDLS260CN	100-260	-	-	10-26	-	-	10-22	-	167	390
RNTDLS500CN	200-500	-	-	20-50	-	-	20-40	-	175	480

Note

1. Bits are sold separately. Refer to page 11.
2. RNTDLS models are required a torque driver tester for torque setting. Specify required torque when you order. (Ex. RNTDLS120CN × 100cN·m)
3. Limit switch specifications AC30V below 1A, DC30V below 1A
4. Female connector for LS cable is sold separately. Part# WA5219K.

POKA Patrol (Count Checker)
CNA-4mk3

Refer to page 31.



* Sold separately

RNTD

Rotary Slip Preset Torque Screwdriver

Assembly

Preset

Rotary Slip

RoHS

Direction



RNTD60CN



RNTD120CN (with Resin Grip)

- Preset version of RTD
- No external scale, Torque value set using tester

Accuracy ±3%

Model	Torque Range			Overall Length [mm]	Weight [g]
	[cN-m] Min.-Max.	[kgf-cm] Min.-Max.	[lbf-in] Min.-Max.		
RNTD15CN	5-15	0.5-1.5	0.5-1.3	95	71
RNTD30CN	10-30	1-3	1-2.5		
RNTD60CN	20-60	2-6	2-5		
RNTD120CN	40-120	4-12	4-10	110	110
RNTD260CN	100-260	10-26	10-22		180
RNTD500CN	200-500	20-50	20-40	120	270

- Note**
1. A torque driver tester is necessary for torque setting. Specify required set torque when you order. (Ex. RNTD120CN × 100cN-m)
 2. Torque adjusting bar is sold separately. Refer to page 46.
 3. Bits are sold separately. Refer to page 11.

- Standard Accessories**
1. Resin grip (for RNTD120CN and RNTD260CN only)
 2. Auxiliary tightening bar (for RNTD500CN only)

NTD

Preset Torque Screwdriver

Assembly

Preset

RoHS

Direction



NTD60CN



NTD120CN (with Resin Grip)

- Preset version of LTD
- No external scale, Torque value set using tester

Accuracy ±3%

Model	Torque Range			Overall Length [mm]	Weight [g]
	[cN-m] Min.-Max.	[kgf-cm] Min.-Max.	[lbf-in] Min.-Max.		
NTD15CN	5-15	0.5-1.5	0.5-1.3	95	70
NTD30CN	10-30	1-3	1-2.5		
NTD60CN	20-60	2-6	2-5		
NTD120CN	40-120	4-12	4-10	110	110
NTD260CN	100-260	10-26	10-22		180
NTD500CN	200-500	20-50	20-40	120	270
NTD1000CN	400-1000	40-100	40-90	155	550

- Note**
1. A torque driver tester is necessary for torque setting. Specify required set torque when you order. (Ex. NTD120CN × 100cN-m)
 2. Torque adjusting bar is sold separately. Refer to page 46.

- Standard Accessories**
1. Resin grip (for NTD120CN and NTD260CN only)
 2. Auxiliary tightening bar (for NTD500CN and NTD1000CN only)

RTDZ/RNTDZ

Direction

Rotary Slip Adjustable/Preset Insulated Torque Screwdriver



RTDZ260CN



RNTDZ500CN

Assembly

Rotary Slip

Resin Body

RoHS

- Insulated design suited for use in electric shock hazard conditions.
- Ideal for electric car assembly, connection of battery terminal wiring work etc.

Accuracy ±3%

S.I. Model	Torque Range [cN-m]		Metric Model	Torque Range [kgf-cm]		Torque Range [lbf-in]		Overall Length [mm]	Weight [g]
	Min.-Max.	Grad.		Min.-Max.	Grad.	Min.-Max.	Grad.		
RTDZ260CN	60-260	2	26RTDZ	6-26	0.2	-	-	150	220
RTDZ500CN	100-500	5	50RTDZ	10-50	0.5	-	-	183	380
RNTDZ260CN	100-260	-	-	10-26	-	10-22	-	123	240
RNTDZ500CN	200-500	-	-	20-50	-	20-40	-	138	340

- Note**
1. RNTDZ models are required a torque driver tester for torque setting. Specify required torque when you order. (Ex. RNTDZ260CN × 200cN-m)
 2. Torque adjusting bar is sold separately. Refer to page 7.
 3. Bits are sold separately. Refer to page 11.
 4. Bits are not insulation coating.

SPECIAL TOOLS FOR TORQUE SCREWDRIVER

RESIN GRIP (for 120CN, 260CN)

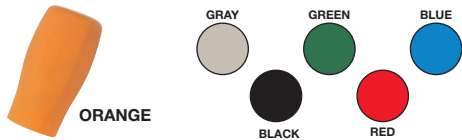

For 120CN

Part #	Color	Applicable Model
850	Orange	RTD120CN LTD120CN RNTD120CN NTD120CN
851	Gray	
852	Black	
853	Green	
854	Red	
855	Blue	

For 260CN

Part #	Color	Applicable Model
856	Orange	RTD260CN LTD260CN
857	Gray	
858	Black	RNTD260CN NTD260CN
859	Green	
860	Red	
861	Blue	

Resin Grip

Dimensions	120CN		260CN	
	RTD LTD	RNTD NTD	RTD LTD	RNTD NTD
Hexagon width across flats Maximum value [mm]	33		41	
Hexagon width across corner Maximum value [mm]	35		44	
Length [mm]	67	67	81	68
Overall Length with torque screwdriver [mm]	130	110	150	110

ADJUSTING TOOL (for RTD/LTD)

- Used for zero adjustment



Part #	Applicable Model
51	LTD/RTD15CN, 30CN
46	LTD/RTD60CN
47	LTD/RTD260CN
48	LTD/RTD500CN
49	LTD/RTD1000CN
1046	LTD/RTD120CN

AUXILIARY TIGHTENING TOOL (for RTD/LTD/RNTD/NTD)

- Make easier for large torque tightening



Part #	Applicable Model
31	LTD/RTD/NTD/RNTD500CN
32	LTD/NTD1000CN
40	LTD2000CN
1031	RTDLS500CN
	RNTDSL500CN

PRESET HOOK SPANNER (for RTD/LTD)

- Make easier for middle and large torque setting



Part #	Applicable Model
52	LTD/RTD260CN
53	LTD/RTD500CN
54	LTD1000CN
55	LTD2000CN

TORQUE ADJUSTING BAR (for RNTD/NTD)

- Used for torque setting of preset torque screwdriver



Part #	Applicable Model
42	NTD/RNTD15CN-120CN
43	NTD/RNTD260CN, RNTDZ
44	NTD/RNTD500CN-1000CN

AMRD/BMRD

Direction



Rotary Slip Adjustable Torque Screwdriver for Small Screws



AMRD4CN



BMRD30CN2

Assembly

Adjustable

Rotary Slip

Graduation

RoHS

- Low torque version of RTD
- AMRD includes special size bits.

Accuracy $\pm 3\%$

S.I. Model	Torque Range [cN·m]		Metric Model	Torque Range [gf·cm/kgf·cm]		American Model	Torque Range [ozf·in/lbf·in]		Overall Length [mm]	Weight [g]	Standard Accessory Bit	
	Min.-Max.	Grad.		Min.-Max.	Grad.		Min.-Max.	Grad.			⊕	⊖ Thickness × Width
AMRD	cN·m	cN·m		gf·cm	gf·cm		ozf·in	ozf·in				
AMRD1CN	0.3-1	0.01	100AMRD	30-100	1	-	-	-				0.15 × 1
AMRD2CN	0.5-2	0.025	200AMRD	50-200	2.5	AMRD3Z	1-3	0.05	93	26	#0	0.2 × 1.5
AMRD4CN	1-4	0.05	400AMRD	100-400	5	AMRD6Z	2-6	0.1				0.3 × 2
AMRD8CN	2-8		800AMRD	200-800	10	AMRD12Z	3-12	0.2				
BMRD		0.1		kgf·cm	kgf·cm		lbf·in	lbf·in				
BMRD15CN2	2-15		1.5BMRD2	0.2-1.5	0.01	1.5BMRD2-A	0.2-1.5	0.005	116	50	-	-
BMRD30CN2	4-30	0.2	3BMRD2	0.4-3	0.02	3BMRD2-A	0.4-3	0.01				

Note

1. Bits for BMRD are sold separately. Refer to page 11.
2. Bits for AMRD are supplied from only Tohnichi.

AMLD/BMLD

Direction



Adjustable Torque Screwdriver for Small Screws



AMLD4CN



BMLD30CN2

Assembly

Adjustable

Graduation

RoHS

- Low torque version of LTD
- AMLD includes special size bits.

Accuracy $\pm 3\%$

S.I. Model	Torque Range [cN·m]		Metric Model	Torque Range [gf·cm/kgf·cm]		American Model	Torque Range [ozf·in/lbf·in]		Overall Length [mm]	Weight [g]	Standard Accessory Bit	
	Min.-Max.	Grad.		Min.-Max.	Grad.		Min.-Max.	Grad.			⊕	⊖ Thickness × Width
AMLD	cN·m	cN·m		gf·cm	gf·cm		ozf·in	ozf·in				
AMLD1CN	0.3-1	0.01	100AMLD	30-100	1	-	-	-				0.15 × 1
AMLD2CN	0.5-2	0.025	200AMLD	50-200	2.5	AMLD3Z	1-3	0.05	83	26	#0	0.2 × 1.5
AMLD4CN	1-4	0.05	400AMLD	100-400	5	AMLD6Z	2-6	0.1				0.3 × 2
AMLD8CN	2-8		800AMLD	200-800	10	AMLD12Z	3-12	0.2				
BMLD		0.1		kgf·cm	kgf·cm		lbf·in	lbf·in				
BMLD15CN2	2-15		1.5BMLD2	0.2-1.5	0.01	1.5BMLD2-A	0.2-1.5	0.005	116	50	-	-
BMLD30CN2	4-30	0.2	3BMLD2	0.4-3	0.02	3BMLD2-A	0.4-3	0.01				

Note

1. Bits for BMLD are sold separately. Refer to page 11.
2. Bits for AMLD are supplied from only Tohnichi.

Daily Check and Calibration of Torque Screwdrivers

Digital Torque Gauges for Daily Inspections

One use of ATGE-G and BTGE-G digital torque gauges is to check the accuracy of small torque screwdrivers such as AMLD/AMRD and BMLD/BMRD. Monitoring drivers with daily inspections confirms driver function and accuracy prior to use.

- Six models of ATGE-G cover a torque capacity from 0.1 cN·m to 20 cN·m.
- Five models of BTGE-G cover a torque capacity from 2 to 20 cN·m.
- #808 (for ATGE-G) and #809 (for BTGE-G) Measurement Board (Optional Accessory shown at the right)



Torque checking figure for AMRD torque screwdriver for small screws with ATGE-G and optional ATGE-G Measurement board



Torque checking figure for BMRD torque screwdriver for small screws with BTGE-G

Torque Driver Tester for Calibration and Adjustments

TDT3-G digital torque driver testers are for the calibration of torque screwdrivers such as RTD/LTD (click type) and FTD (indicating type). The loading device keeps the driver steady and in a vertical position during testing for highly accurate calibration and easy adjustments.

- TDT60CN3-G (2-60 cN·m)
- TDT600CN3-G (20-600 cN·m)



Calibration figure for torque screwdriver RTD left and FTD right with TDT3-G

FTD

Dial Indicating Torque Screwdriver with Memory Pointer

Direction

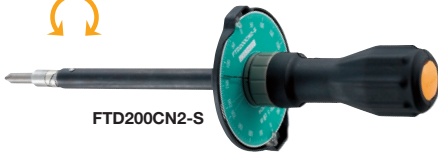

FTD200CN2-S



FTD100CN

Inspection

Dial Indicating

Memory Pointer

Direct Reading

RoHS

- Ideal for measuring torque
- FTD-S with memory pointer; FTD with preset knob

Accuracy ±3%

S.I. Model	Torque Range [cN-m]		Metric Model	Torque Range [gf-cm/kgf-cm]		American Model	Torque Range [ozf-in/lbf-in]		Overall Length [mm]	Weight [g]	Standard Accessory Bit	
	Min.-Max.	Grad.		Min.-Max.	Grad.		Min.-Max.	Grad.			⊕	⊖ Thickness × Width
FTD-S	cN-m	cN-m		gf-cm	gf-cm		ozf-in	ozf-in				
FTD20CN-S	0.3-2	0.05	02FTD2-S	30-200	5	FTD3Z2-S	0.5-3	0.1				
FTD5CN-S	0.5-5	0.1	05FTD2-S	50-500	10	FTD7Z2-S	1-7	0.2				
				kgf-cm	kgf-cm				152	140		
FTD10CN-S	1-10	0.2	1FTD2-S	0.1-1	0.02	FTD15Z2-S	2-15	0.5				Interchangeable bit is sold separately. Refer to page 11.
FTD20CN-S	3-20	0.5	2FTD2-S	0.3-2	0.05	FTD30Z2-S	5-30	1				
FTD50CN2-S	5-50	1	5FTD2-S	0.5-5	0.1	FTD70Z2-S	10-70	2				
							lbf-in	lbf-in				
						5FTD2-A-S	0.5-5	0.1	272	370		
FTD100CN2-S	10-100	2	10FTD2-S	1-10	0.2	10FTD2-A-S	1-10	0.2				
FTD200CN2-S	30-200	5	20FTD2-S	3-20	0.5	20FTD2-A-S	3-20	0.5				
FTD400CN2-S	50-400	10	40FTD2-S	5-40	1	40FTD2-A-S	5-40	1				
	N-m	N-m										
FTD8N2-S	1-8	0.2	80FTD2-S	10-80	2	80FTD2-A-S	10-70	2	338	900	# 3	1.2 × 8
FTD16N2-S	3-16	0.5	160FTD2-S	30-160	5	160FTD2-A-S	20-140	5		930		
FTD	cN-m	cN-m										
FTD50CN	10-50	1	5FTD	1-5	0.1	5FTD-A	1-5	0.1	215	285	# 1	0.7 × 7
FTD100CN	20-100	2	10FTD	2-10	0.2	10FTD-A	1-10	0.2		290		
FTD200CN	40-200	5	20FTD	4-20	0.5	20FTD-A	3-20	0.5	263	390	# 2	0.9 × 7
FTD400CN	80-400	10	40FTD	8-40	1.0	40FTD-A	5-40	1		410		

Note FTD8N2-S, FTD16N2-S: Square drive type (6.35mm).

Standard Accessories Auxiliary tightening bar (for FTD8N2-S and FTD16N2-S only)

MTD

Micro Dial Indicating Torque Screwdriver

Direction

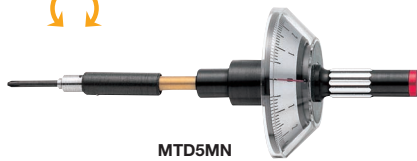

MTD5MN

Inspection

Dial Indicating

Direct Reading

RoHS

- Low torque capacity version of FTD
- Requires special size bits

Accuracy ±3%

S.I. Model	Torque Range [mN-m]		Metric Model	Torque Range [gf-cm]		American Model	Torque Range [ozf-in]		Overall Length [mm]	Weight [g]	Standard Accessory Bit	
	Min.-Max.	Grad.		Min.-Max.	Grad.		Min.-Max.	Grad.			⊕	⊖ Thickness × Width
MTD1MN	0.1-1	0.02	10MTD	1-10	0.2	-	-	-	110	22		0.15 × 1
MTD2MN	0.3-2	0.05	20MTD	3-20	0.5	-	-	-	100	21	# 0	0.2 × 15
MTD5MN	0.5-5	0.1	50MTD	5-50	1	MTD07Z	0.1-0.7	0.02				0.3 × 2
MTD10MN	1-10	0.2	100MTD	10-100	2	MTD1.4Z	0.2-1.4	0.02	132	23		

Note MTD models require Tohnichi made bits. Refer to page 11.



STC2-G STC2-G-BT

Digital Torque Screwdriver

Assembly

Inspection

Digital

Bit

Direct Reading

Rechargeable

RoHS



- Ideal for tightening and inspection operation
- 1000 data memory storage and data output function
- LED (White, Blue, and Yellow/Red) indicator

Direction



STC200CN2-G

Model		Torque Range								Overall Length [mm]	Weight [g]
		[cN·m]		[kgf·cm]		[lbf·in]		[ozf·in]			
standard version	Bluetooth version	Min.-Max.	1 digit	Min.-Max.	1 digit	Min.-Max.	1 digit	Min.-Max.	1 digit		
STC50CN2-G	NEW STC50CN2-G-BT	10-50	0.05	1-5	0.005	1-4.4	0.005	15-70	0.05		
STC200CN2-G	NEW STC200CN2-G-BT	40-200	0.2	4-20	0.02	4-17	0.02	-	-	230	325
STC400CN2-G	NEW STC400CN2-G-BT	80-400	0.5	8-40	0.05	8-35	0.05	-	-		

Accuracy ±1%

Note

1. Bits are sold separately. Refer to page 11.
2. Bits size as below
3. Refer to page 30 for condition of wireless equipment in each country.
4. Data output of standard version is through USB only.
5. Data output of Bluetooth version is through USB and Bluetooth.

Standard Accessories

USB cable/384, AC adapter/BA-7, and Battery pack/BP-7. Refer to page 47.

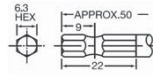

White LED light (80% of target torque)



Blue LED light (Achieving target torque)



Yellow & Red flashing LED light (Over torque)

Display can be turned upside down with keypad operation.

[EX.] Torque checking figure for torque screwdriver



STC2-G

STC2-G Optional Accessories



AC Adapter (P.47)

Model	Applicable Model
BA-7	STC2-G



Battery Pack (P.47)

Model	Applicable Model
BP-7	STC2-G



PC Connecting Cable (P.47)

Model	Applicable Model
384	STC2-G (P.10), ST3-G (P.56), ATGE-G (P.58), BTGE-G (P.59)

Interchangeable Bit

RoHS

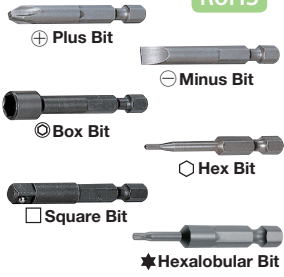

From Torque Tool							
Applicable Torque Screwdriver	-	RTD/RTDZ/LTD BMRD BMLD FTD50CN - 400CN FTD2CN-S - 400CN2-S STC2-G		FTD8N2-S - FTD16N2-S, (FTD8N - 16N)	AMRD AMLD MTD	LTD2000CN	-
Applicable Power Torque Tool	U30CN	U (except U30CN)		-	-	-	AUR5N
Root Shape Sign	A	B	C	D	F	G	H
Root Shape and Dimensions							

From Bolt	Sign	Size	Screw	Tohnichi Original Bit		Common (Standard)		Tohnichi Original Bit		Common (Standard)				
				Tohnichi Original Bit	Tohnichi Original Bit	Tohnichi Original Bit	Tohnichi Original Bit	Tohnichi Original Bit	Tohnichi Original Bit					
Plus	⊕	0	#0 (S-0)	Refer to Table A	104		109		115					
		1	#1 (H-1)	Refer to Table A		85	106	84	116					
		2	#2 (H-2)	Refer to Table A		86	107	80						
		3	#3 (H-3)	Refer to Table A		87		81		35	700			
		4	#4 (H-4)	Refer to Table A						36				
	Minus	⊖	10	0.15 × 1	Refer to Table B					111				
			11	0.2 × 1.5	Refer to Table B					112				
			12	0.3 × 2	Refer to Table B					113				
			13	0.4 × 2.4	Refer to Table B	105								
			14	0.6 × 3.8	Refer to Table B			108						
			15	0.7 × 7	Refer to Table B		88							
			16	0.9 × 7	Refer to Table B		89							
			17	1 × 10	Refer to Table B							37		
			18	1 × 12	Refer to Table B							38		
			19	1.2 × 17	Refer to Table B							39		
			20	1.6 × 10	Refer to Table B					82				
			21	1.2 × 8	Refer to Table B					83				
			Box	⊙	Hex Bolt									
					W 5.5	5.5	M3		91					
					W 6	6	(M3.5)		95					
					W 7	7	M4		92					
W 8	8	(M4.5) M5				93								
W 10	10	M6				94								
Hex	⬡	Cap Screw			Set Screw									
		W 1.27			1.27		M2.5		56					
		W 1.5			1.5		M3		57					
		W 2			2	M2.5	M4		58					
		W 2.5	2.5	M3	M5		59							
		W 3	3	M4	M6		60							
		W 4	4	M5	M8		61							
		W 5	5	M6	M10		62							
		W 6	6	M8	M12 (M14)		63							
		W 8	8	M10	M16 (M18)		64							
Square Drive	□	2	□6.35	(1/4)						33				
		3	□9.53	(3/8)						34				
Hexalobular	★	Flat Head		Socket Head	Set Screw									
		T 5	M2		M2.5		470							
		T 6	M2		M3		471							
		T 7			M3.5									
T 8	M2.5	M2.5	M4		472									

Bolt Head Shape (Ref.)

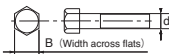

Nominal Size of Screw (d)	Hex head Bolt (B)	Small Hex Head Bolt (B)	High Strength Hex Bolt for Friction Grip Joint (B)	Hex Socket Head Cap Screw (B)	Hex Socket Set Screw (B)
M2.5	4.5	-	-	2	1.27
M3	5.5	-	-	2.5	1.5
(M3.5)	6	-	-	-	-
M4	7	-	-	3	2
(M4.5)	8	-	-	-	-
M5	8	-	-	4	2.5
M6	10	-	-	5	3
(M7)	11	-	-	-	-
M8	13	12	-	6	4
M10	16	17	14	8	5
M12	18	19	17	22	10
(M14)	21	22	19	12	6
M16	24	22	27	14	8
(M18)	27	24	-	-	-
M20	30	27	32	17	10
(M22)	32	34	30	36	-
M24	36	32	41	19	-
(M27)	41	36	46	-	-
M30	46	41	50	22	-
(M33)	50	46	-	24	-
M36	55	50	-	-	-
(M39)	60	55	-	27	-
M42	65	-	-	32	-
JIS	JIS B 1180	JIS B 1180	JIS B 1186	JIS B 1176	JIS B 1177

Hex Bolt

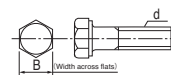

Cap Screw

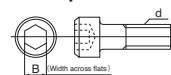

Set Screw

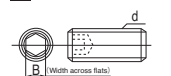

Flat Head Screw

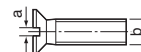

How to order:

Indicate the model name and catalog No.

(EXAMPLE) MODEL NAME CATALOG No.

⊕BIT A-0 104

Root Shape Sign Point Shape Sign

Size of Bits

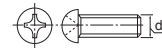

Table A

No. of Cross Nominal Size of Screw	Hole No.	Remark
M1.6, M2	#0 (S-0)	
[M2], (M2.2), M2.5, (M3)	#1 (H-1)	Pan head screw, Flat head screw, Pan flat screw, Bind screw
M3, (M3.5), M4, (M4.5), M5	#2 (H-2)	[(M3) #1 is bind small screw only]
M6	#3 (H-3)	[(M2) #1 is not compliant with ISO]
M8, M10	#4 (H-4)	

Table B

Nominal Size (a)	M1	M1.2	(M1.4)	M1.6	(M1.7)	M2	(M2.2)	M2.3	M2.5	(M2.6)	M3	(M3.5)	M4	(M4.5)	M5	M6	M8	M10
ISO Screws				0.4		0.5			0.6		0.8	1	1.2		1.2	1.6	2	2.5
Non-ISO Screws		0.32		0.4		0.6			0.8			1			1.2	1.6		



QL/QL2

Ratchet Head Type Adjustable Torque Wrench

Assembly Adjustable Ratchet Head Graduation RoHS

Direction



QL5N



QL750N2



QL100N4

Accuracy ±3%

QL/QL-MH Optional Accessories



842



846

Carrying Case (P.46)

Part #	Applicable Model Dimension [mm]
842	QL50N, QL50N-MH, QL100N4-MH (H60 × W400 × D70)
843	QL140N, QL140N-MH, QL200N4, QL200N4-MH (H60 × W520 × D80)
846	QL140N, QL140N-MH and below (H170 × W500 × D100)
847	QL280N, QL280N-MH and below (H170 × W740 × D100)



862

863

864

Color Cap

Part #	Color	Applicable Model
862	Red	QL2N, QL5N
863	Blue	QL10N, QL15N,
864	Green	QL25N5-1/4,
865	Black	QL25N5

NEW



Protective Head Cover

Refer to page 46.

S.I. Model	Torque Range [N-m]		Metric Model	Torque Range [kgf-cm/kgf-m]		American Model	Torque Range [lbf-in/lbf-ft]		Overall Length [mm]	Square Drive [mm]	Weight [kg]
	Min.-Max.	Grad.		Min.-Max.	Grad.		Min.-Max.	Grad.			
QL	N-m	N-m		kgf-cm	kgf-m		lbf-in	lbf-in			
QL2N	0.4-2	0.02	20QL	4-20	0.2	QL15I-2A	3-15	0.1	194		0.27
QL5N	1-5	0.05	50QL	10-50	0.5	QL30I-2A	6-30	0.2		6.35	0.29
QL10N	2-10		100QL	20-100		QL50I-2A	10-50		0.5	219	
QL15N	3-15	0.1	150QL	30-150	1	QL100I-2A	20-100	1			
QL25N5-1/4	5-25	0.2	225QL5-1/4	50-250	2.5	QL200I-2A	50-200	2.5	237		0.33
QL25N5			225QL5			QL200I-3A					
QL50N	10-50	0.5	450QL3	100-500	5	QL400I-3A	100-400	5	260		0.45
						QL750I-3A	150-750	10		9.53	
							lbf-ft	lbf-ft			
QL100N4-3/8	20-100		900QL4-3/8	200-1000		QL75F-3A	15-75	1	335		0.69
QL100N4	20-100	1	900QL4	200-1000	10						
QL140N	30-140		1400QL3	300-1400		QL100F-4A	30-100	1	400		0.88
QL200N4	40-200		1800QL4	400-2000	20	QL150F-4A	30-150		490	12.7	1.4
				kgf-m	kgf-m						
QL280N-1/2		2	2800QL3-1/2			QL200F-4A	30-200	2			
QL280N	40-280		2800QL3	4-28					695		2.0
QL420N	60-420		4200QL2	6-42	0.2	QL300F-6A	60-300		995		3.4
	N-m	N-m		kgf-m	kgf-m		lbf-ft	lbf-ft		19.05	
QLE550N2	100-550		5500QLE2	10-55		QLE400F-6A	100-400		1189		4.3
QLE750N2	150-750	5	7500QLE2	15-75	0.5	QLE600F-6A	150-600	5	1342		5.6
QLE1000N2	200-1000		10000QLE2	20-100		QLE700F-8A	200-700		1515		7.7
QLE1400N2	300-1400		14000QLE2	30-140		QLE1000F-8A	300-1000		1787	25.4	11.1
QLE2100N2	500-2100	10	21000QLE2	50-210	1	QLE1500F-8A	500-1500	10	1895		14.6
QLE2800N2	800-2800	20	28000QLE2	80-280	2	QLE2000F-12A	600-2000	20	2405	38.1	23.7

Note 1. QL2N-QL25N5 are yellow/black resin grips. QL50N-QL280N are black resin grips.
2. QL420N and QLE550N2-QLE2800N2 are knurled handles.
3. QLE2800N2 has 25.4mm square drive, use a through-hole socket.

QLLS RoHS

- QL style with Limit Switch output
- Ideal for torque verification (Pokayoke) assembly processes



QLLS100N4

POKA Patrol (Count Checker) CNA-4mk3

Refer to page 31.



* Sold separately

S.I. Model	Metric Model
QLMS2N-MH	20QLMS-MH
QLMS5N-MH	50QLMS-MH
QLMS10N-MH	100QLMS-MH
QLMS10N	100QLMS
QLMS15N	150QLMS
QLMS15N-MH	150QLMS-MH
QLLS25N5	225QL5LS
QLLS50N	450QL3LS
QLLS100N4	900QL4LS
QLLS140N	1400QL3LS
QLLS200N4	1800QL4LS
QLLS280N	2800QL3LS
QLLS420N	4200QL2LS

QL-MH

Ratchet Head Type Adjustable Torque Wrench with Metal Handle

Assembly Adjustable Ratchet Head Graduation RoHS

Direction



QL100N4-MH



QL5N-MH

- Knurled metal handle version of QL
- Ideal for oily working conditions

Accuracy ±3%

S.I. Model	Torque Range [N-m]		Metric Model	Torque Range [kgf-cm/kgf-m]		American Model	Torque Range [lbf-in]		Overall Length [mm]	Square Drive [mm]	Weight [kg]
	Min.-Max.	Grad.		Min.-Max.	Grad.		Min.-Max.	Grad.			
QL2N-MH	0.4-2.0	0.02	20QL-MH	kgf-cm	kgf-m	QL15I-2A-MH	lbf-in	lbf-in	160		0.16
QL5N-MH	1-5	0.05	50QL-MH	4-20	0.2	QL30I-2A-MH	3-15	0.1		6.35	
QL10N-MH	2-10		100QL-MH	10-50	0.5	QL50I-2A-MH	6-30	0.2			0.19
QL15N-MH	3-15	0.1	150QL-MH	20-100		QL100I-2A-MH	10-50	0.5	195		
QL25N-MH	5-25	0.25	225QL-MH	30-150	1		20-100	1			0.25
QL50N-MH	10-50	0.5	450QL-MH	50-250	2.5	-	-	-	230	9.53	0.45
QL100N4-MH	20-100		900QL4-MH	100-500	5	-	-	-	260		0.45
QL140N-MH	30-140		1400QL-MH	200-1000		-	-	-	335		0.69
QL200N4-MH	40-200	1	1800QL4-MH	300-1400	10	-	-	-	400	12.7	0.88
				400-2000	20	-	-	-	490		1.4
				kgf-m	kgf-m						
QL280N-MH	40-280	2	2800QL-MH	4-28	0.2	-	-	-	695	19.05	1.9

CL/CLE2

Interchangeable Head Type Adjustable Torque Wrench

Assembly Adjustable Interchangeable Graduation RoHS

Direction



- Heads types can be easily exchanged.
- Torque value easily set with external scale and knob



CL2N×8D



CLE850N2×32D



CL100N×15D

Interchangeable Head

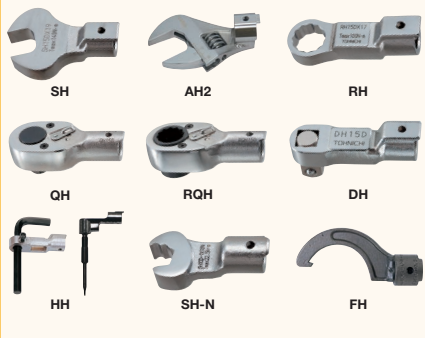

CL/CL-MH Optional Accessories



842



846

Carrying Case (P.46)

Part #	Applicable Model Dimension [mm]
842	CL50N×(12D/15D), CL50N×(12D/15D)-MH, CL100N×15D-MH (H60 × W400 × D70)
843	CL140N×15D(-MH), CL200N×19D(-MH) (H60 × W520 × D80)
846	CL200N×19D, CL200N×19D and below (H170 × W500 × D100)
847	CL280N×22D, CL280N×22D-MH and below (H170 × W740 × D100)



862



863



864

Color Cap

Part #	Color	Applicable Model
862	Red	CL2N×8D, CL5N×8D CL10N×8D, CL15N×8D CL25N×10D
863	Blue	
864	Green	
865	Black	

Tohnichi Head Size	S.I. Model	Torque Range [N·m]		Metric Model	Torque Range [kgf·cm/kgf·m]		American Model	Torque Range [lbf·in/lbf·ft]		Overall Length [mm]	Weight [kg]
		Min.-Max.	Grad.		Min.-Max.	Grad.		Min.-Max.	Grad.		
8D	CL	N·m	N·m		kgf·cm	kgf·cm		lbf·in	lbf·in	174	0.24
	CL2N×8D	0.4-2	0.02	20CL	4-20	0.2	CL15l×8D	3-15	0.1		
	CL5N×8D	1-5	0.05	50CL	10-50	0.5	CL30l×8D	6-30	0.2		
	CL10N×8D	2-10	0.1	100CL	20-100	1	CL50l×8D	10-50	0.5		
10D	CL15N×8D	3-15		150CL	30-150		CL100l×8D	20-100		199	0.26
	CL25N5×10D	5-25	0.2	225CL5	50-250	2.5	CL200l×10D	50-200	2.5		
12D	CL50N×12D			450CL3			450CL3-A	100-400		230	0.37
	CL50N×15D	10-50	0.5	500CL3	100-500	5	500CL3-A	100-450	5		
15D	CL100N×15D	20-100		900CL3	200-1000		900CL3-A	200-800	10	310	0.52
			1					lbf·ft	lbf·ft		
19D	CL140N×15D	30-140		1400CL3	300-1400		1400CL3-A	30-100	1	370	0.67
	CL200N×19D	40-200		1800CL3	400-2000	20	1800CL3-A	30-150			
22D			2		kgf·m	kgf·m				655	1.8
	CL280N×22D	40-280		2800CL3	4-28	0.2	2800CL3-A	30-200	2		
27D	CL420N×22D	60-420		4200CL2	6-42		4200CL2-A	60-300		940	3.1
								lbf·ft	lbf·ft		
32D	CLE2	N·m	N·m		kgf·m	kgf·m				1148	3.9
	CLE550N2×27D	100-550		5500CLE2	10-55		CLE400F×27D	100-400			
	CLE750N2×27D	150-750		7500CLE2	15-75	0.5	CLE550F×27D	150-550			
	CLE850N2×32D	200-850	5	8500CLE2	20-85		CLE600F×32D	150-600	5		
	CLE1200N2×32D	300-1200		12000CLE2	30-120		CLE900F×32D	200-900		1464	6.9

- Note
1. Overall length does not include interchangeable head. Interchangeable heads are optional.
 2. Use CSP model (P.19) for PH (Pipe wrench head) type interchangeable head.
 3. CL2N - CL25N5 are yellow/black resin grips. CL50N - CL280N are black resin grips.
 4. CL420N and CLE550N2-CLE1200N2 are knurled handles.

Standard Accessories Adjusting handle (for CLE550N2-CLE1200N2)

CLLS RoHS

- CL style with Limit Switch output
- Ideal for torque verification (Pokayoke) assembly processes

S.I. Model	Metric Model
CLMS2N×8D-MH	20CLMS-MH
CLMS5N×8D-MH	50CLMS-MH
CLMS10N×8D-MH	100CLMS-MH
CLMS10N×8D	100CLMS
CLMS15N×8D	150CLMS
CLMS15N×8D-MH	150CLMS-MH
CLLS25N5×10D	225CL5LS
CLLS50N×12D	450CL3LS
CLLS100N×15D	900CL3LS
CLLS140N×15D	1400CL3LS
CLLS200N×19D	1800CL3LS
CLLS280N×22D	2800CL3LS
CLLS420N×22D	4200CL2LS

POKA Patrol (Count Checker) CNA-4mk3

Refer to page 31.



* Sold separately

CL-MH

Interchangeable Head Type Adjustable Torque Wrench with Metal Handle

Direction



Assembly Adjustable Interchangeable Graduation RoHS

- Knurled metal handle version of CL
- Ideal for oily working conditions



CL100N×15D-MH



CL5N×8D-MH

Tohnichi Head Size	S.I. Model	Torque Range [N·m]		Metric Model	Torque Range [kgf·cm/kgf·m]		American Model	Torque Range [lbf·in]		Overall Length [mm]	Weight [kg]
		Min.-Max.	Grad.		Min.-Max.	Grad.		Min.-Max.	Grad.		
8D	CL2N×8D-MH	0.4-2	0.02	20CL-MH	4-20	0.2	CL15l×8D-MH	3-15	0.1	140	0.13
	CL5N×8D-MH	1-5	0.05	50CL-MH	10-50	0.5	CL30l×8D-MH	6-30	0.2		
	CL10N×8D-MH	2-10		100CL-MH	20-100		CL50l×8D-MH	10-50	0.5		
	CL15N×8D-MH	3-15	0.1	150CL-MH	30-150	1	CL100l×8D-MH	20-100	1	175	0.16
10D	CL25N×10D-MH	5-25	0.25	225CL-MH	50-250	2.5	-	-	-	200	0.22
12D	CL50N×12D-MH			450CL-MH			-	-	-	230	0.37
	CL50N×15D-MH	10-50	0.5	500CL-MH	100-500	5	-	-	-		
15D	CL100N×15D-MH	20-100		900CL-MH	200-1000		-	-	-	310	0.52
	CL140N×15D-MH	30-140	1	1400CL-MH	300-1400		-	-	-		
19D	CL200N×19D-MH	40-200		1800CL-MH	400-2000	20	-	-	-	455	1.2
22D			2		kgf·m	kgf·m				655	1.6
	CL280N×22D-MH	40-280		2800CL-MH	4-28	0.2	-	-	-		

- Note
1. Overall length does not include interchangeable head.
 2. Use CSP model (P.19) for PH (Pipe wrench head) type interchangeable head is not available for this model.
 3. Interchangeable heads are optional.

DQL/DQLE2

Direction

Dual Square Drives
Type Adjustable Torque
Wrench



Assembly

Adjustable

Ratchet Head

Graduation

Bi-Directional

RoHS

- For bi-directional tightening
- Ideal for tightening large vehicle tires



DQL200N4



DQLE750N2

■ DQL200N4 Optional Accessories

Carrying Case (P.46)

Part #	Applicable Model Dimension [mm]	Weight [kg]
843	DQL200N4 (H60 × W520 × D80)	0.36
847	DQL280N and below (H170 × W740 × D100)	1.0

S.I. Model	Torque Range [N-m]		Metric Model	Torque Range [kgf-cm/kgf-m]		American Model	Torque Range [lbf-ft]		Overall Length [mm]	Square Drive [mm]	Weight [kg]
	Min.-Max.	Grad.		Min.-Max.	Grad.		Min.-Max.	Grad.			
DQL	N-m	N-m		kgf-cm	kgf-cm						
DQL200N4	40-200		1800DQL4	400-2000	20	1800DQL4-A	30-150		490	12.7	1.4
		2		kgf-m	kgf-m			2			
DQL280N	40-280		2800DQL3	4-28	0.2	2800DQL3-A	30-200		695		2.0
DQLE2	N-m	N-m		kgf-m	kgf-m		lbf-ft	lbf-ft		19.0	
DQLE550N2	100-550		5500DQLE2	10-55		DQLE400F-6A	100-400		1189		4.4
DQLE750N2	150-750	5	7500DQLE2	10-75	0.5	DQLE600F-6A	150-600	5	1342		5.7
DQLE1000N2	200-1000		10000DQLE2	10-100		DQLE700F-8A	200-700		1515	25.4	7.9

Note 1. DQL200N4 and DQL280N have resin grips.
2. For the model having 25.4mm square drive, use a through-hole socket.
3. DQLE550N2-DQLE1000N2 have knurled handles.

Standard Accessories Adjusting handle (for DQLE550N2-DQLE1000N2)

MTQL Torque Wrench for Motorsports

Direction



MTQL70N

Assembly

Adjustable

Ratchet Head

Graduation

RoHS

- Wide capacity adjustable style
- Ideal for motorcycle & motorbike maintenance

S.I. Model	Torque Range [N-m]		Metric Model	Torque Range [kgf-m]		Overall Length [mm]	Square Drive [mm]	Weight [kg]
	Min.-Max.	Grad.		Min.-Max.	Grad.			
MTQL40N	5-40	0.5	400MTQL	0.5-4	0.05	250	9.5	0.45
MTQL70N	10-70		700MTQL	1-7		285		0.47
MTQL140N	20-140	1	1400MTQL	2-14	0.1	400	12.7	0.77

Standard Accessories Carrying case

■ MTQL Optional Accessories



842



846

Carrying Case (P.46)

Part #	Applicable Model Dimension [mm]	Weight [kg]
842	MTQL40N, MTQL70N (H60 × W400 × D70)	0.25
843	MTQL140N (H60 × W520 × D80)	0.36
846	MTQL140N and below (H170 × W500 × D100)	1.0

MT70N Moto Tork (Pre-Lock Adjustable Specialty Torque Wrench)

Direction



MT70N

Assembly

Pre-Lock

Interchangeable

Graduation

RoHS

- Converts basic hand tools into torque wrenches
- Ideal for motorcycle maintenance

S.I. Model	Torque Range [N-m]		Metric Model	Torque Range [kgf-m]		Overall Length [mm]	Weight [kg]
	Min.-Max.	Grad.		Min.-Max.	Grad.		
MT70N	10-70	0.2	MT-7	1.0-7.0	0.02	238	0.65

Note 1. Ring head wrench (shown in the photo) is not included.
2. Max. clamp width for interchangeable tool is approx. 21mm.
3. Min. interchangeable hex wrench key size is 5mm.

Standard Accessories 1. Carrying case
2. Hex key wrench (for torque adjustment)

TiQL/TiQLE

Direction

Titanium Type Adjustable Torque Wrench



TiQL180N



TIEQLE750N

Assembly Pre-Lock Ratchet Head Graduation Titanium Material RoHS

- 50% lighter than standard wrenches
- Ideal for working overhead

Accuracy ±3%

S.I. Model	Torque Range [N·m]		Metric Model	Torque Range [kgf·cm/kgf·m]		Overall Length [mm]	Square Drive [mm]	Weight [kg]
	Min.-Max.	Grad.		Min.-Max.	Grad.			
TiQL				kgf·cm	kgf·cm			
TiQL180N	40-180		1800TiQL	40-1800	20	494	12.7	0.9
TiLQL180N		2	1800TiLQL			594		1.0
TiEQL360N	80-360		3600TiEQL	8-36	0.2	987	19.0	2.4
TiQLE	N·m	N·m		kgf·m	kgf·m			
TiEQLE750N	100-750	5	7500TiEQLE	10-75	0.5	1365		4.5
TiEQLE1400N	200-1400	10	14000TiEQLE	20-140	1	1794	25.4	7.5

Note For the model having 25.4mm square drive, use a through-hole socket.

Standard Accessories 1. Hex key and Color marking bands (for TiQL180N, TiLQL180N and TiEQL360N)
2. Adjusting tool (for TiEQLE750N, TiEQLE1400N)

TiEQLE Optional Accessories



Adjusting Tool for TiEQLE (P.46)

Part #	Applicable Model
301	TiEQLE750N, 1400N

TiQLLS RoHS

- TiQL style with Limit Switch output
- Ideal for torque verification (Pokayoke) assembly processes

S.I. Model	Metric Model
TiQLLS180N	1800TiQLLS
TiLQLLS180N	1800TiLQLLS
TiEQLLS360N	3600TiEQLLS

POKA Patrol (Count Checker)

CNA-4mk3

Refer to page 31.



* Sold separately

PHL/PHLE2

Direction

Pipe-Wrench Head Type Adjustable Torque Wrench



PHL140N



PHLE1300N2

Assembly Adjustable Graduation Pipe-Wrench Head RoHS

- Ideal for use with pipes and plumbing applications

Accuracy ±5%

S.I. Model	Torque Range [N·m]		Metric Model	Torque Range [kgf·cm/kgf·m]		American Model	Torque Range [lbf·in/lbf·ft]		Grippable Pipe Dia. [mm]	Overall Length [mm]	Weight [kg]
	Min.-Max.	Grad.		Min.-Max.	Grad.		Min.-Max.	Grad.			
PHL				kgf·cm	kgf·m		lbf·in	lbf·ft			
PHL50N	10-50	0.5	500PHL3	100-500	5	450PHL3-A	100-400	5		316	1.46
PHL100N	20-100		900PHL3	200-900		900PHL3-A	15-75			472	1.61
PHL140N	30-140	1	1400PHL3	400-1400	10	1400PHL3-A	30-100	1	13-38	530	1.76
PHL200N	40-200		1800PHL3	400-1800	20	1800PHL3-A	30-150			620	2.3
PHL280N	40-280	2	2800PHL3	4-28		2800PHL3-A	30-200	2		833	2.92
PHL420N	60-420	3	4200PHL	6-42	0.2	4200PHL-A	60-300			1122	4.83
PHLE2	N·m	N·m		kgf·m	kgf·m		lbf·ft	lbf·ft			
PHLE850N2	200-850		8500PHLE2	20-85		PHLE600F	150-600		26-52	1664	8.2
PHLE1300N2	300-1300	5	13000PHLE2	30-130	0.5	PHLE900F	200-900	5		1831	10

Note 1. PHLE2 Models have extension bar handle.
2. PHL420N, PHLE850N2, and PHLE1300N2 have knurled handles.

Standard Accessories Adjusting handle (for PHLE850N2 and PHLE1300N2)

QRSP Open Ring Head Type Preset Torque Wrench

Direction



QRSP38N×17

Assembly Preset Open Ratchet Head RoHS

- Ring head opens to allow fitting on tubes or pipes.

Accuracy ±3%

Model	Torque Range		Overall Length [mm]	Weight [kg]
	[N·m] Min.-Max.	[kgf·cm] Min.-Max.		
QRSP38N×17			300	
QRSP38N×19	10-45	100-450	305	0.4
QRSP38N×21				
QRSP38N×24			310	0.43

Note A torque wrench tester is necessary for torque setting. Specify required set torque when you order. (Ex. QRSP38N×17 × 25N·m)

QRSP Optional Accessories

Thrusting Tool for QRSP (P.46)

Part #	Tool #	Applicable Model
312	A-3	QRSP38N

QRSPLS RoHS

- QRSP style with Limit Switch output
- Ideal for torque verification (Pokayoke) assembly processes

Model	Weight [kg]
QRSPLS38N×17	
QRSPLS38N×19	0.4
QRSPLS38N×21	
QRSPLS38N×24	0.43

POKA Patrol (Count Checker)

CNA-4mk3

Refer to page 31.



* Sold separately

PQL

Ratchet Head Type
Pre-Lock Torque
Wrench

Direction



Assembly Pre-Lock Ratchet Head Graduation RoHS

- External scale but requires hex key to set



PQL100N4

Accuracy ±3%

S.I. Model	Torque Range [N·m]		Metric Model	Torque Range [kgf·cm/kgf·m]		American Model	Torque Range [lbf·in/lbf·ft]		Overall Length [mm]	Square Drive [mm]	Weight [kg]
	Min.-Max.	Grad.		Min.-Max.	Grad.		Min.-Max.	Grad.			
PQL10N	2-10		100PQL	20-100	kgf·cm	PQL50I-2A	10-50	0.5	190	6.35	0.19
PQL15N	3-15	0.1	150PQL	30-150	kgf·cm	PQL100I-2A	20-100	1			
PQL25N	5-25	0.25	225PQL	50-250	2.5	225PQL-A	50-200	2.5	215	9.53	0.25
PQL50N	10-50	0.5	450PQL	100-500	5	450PQL-A	100-400	5	260		
PQL100N4	20-100		900PQL4	200-1000	kgf·m	900PQL4-A	15-75	lbf·ft	320	12.7	0.65
PQL140N	30-140	1	1400PQL	300-1400	kgf·m	1400PQL-A	30-100	1			
PQL200N4	40-200		1800PQL4	400-2000	20	1800PQL4-A	30-150	2	470	1.40	
PQL280N	40-280	2	2800PQL	4-28	0.2	-	-	-	670	19.05	2.0
PQL420N	60-420		4200PQL	6-42		-	-	-	975		

Standard Accessories Hex key (for torque adjustment)

PQL Optional Accessories



842



846

Carrying Case (P.46)

Part #	Applicable Model Dimension [mm]	Weight [kg]
842	50N-100N4 (H60 × W400 × D70)	0.25
843	140N-200N4 (H60 × W520 × D80)	0.36
846	200N and below (H170 × W500 × D100)	1.0
847	280N and below (H170 × W740 × D100)	0.36

NEW



Protective Head Cover
Refer to page 46.

PQLLS

RoHS

- PQL style with Limit Switch output
- Ideal for torque verification (Pokayoke) assembly processes

S.I. Model	Metric Model
PQLLS25N	225PQLLS
PQLLS50N	450PQLLS
PQLLS100N4	900PQL4LS
PQLLS140N	1400PQLLS
PQLLS200N4	1800PQL4LS
PQLLS280N	2800PQLLS
PQLLS420N	4200PQLLS

POKA Patrol (Count Checker)
CNA-4mk3

Refer to page 31.



* Sold separately

PQLZ

Pre-Lock Adjustable
Insulated Torque
Wrench

Direction



PQLZ100N4

Assembly Pre-Lock Ratchet Head Graduation Vinyl Coating

- Insulated casing prevents electrical shocks.
- Specialized version of PQL

Accuracy ±3%

S.I. Model	Torque Range [N·m]		Metric Model	Torque Range [kgf·cm]		Overall Length [mm]	Square Drive [mm]	Weight [kg]
	Min.-Max.	Grad.		Min.-Max.	Grad.			
PQLZ25N	5-25	0.25	225PQLZ	50-225	2.5	227	9.5	0.28
PQLZ100N4	20-100	1	900PQLZ4	200-900	10	340	12.7	0.80

Standard Accessories Hex key (for torque adjustment)

QSPZ

Preset Insulated
Torque Wrench

Direction



QSPZ25N

Assembly Preset Vinyl Coating

- Insulated design suited for use in electric shock hazard conditions
- Ideal for electric car assembly, connection of battery terminal wiring work etc.

Accuracy ±3%

Model	Torque Range			Overall Length [mm]	Square Drive [mm]	Weight [kg]
	[N·m]	[kgf·cm]	[lbf·in]			
QSPZ25N	5-25	50-250	50-200	227	9.5	0.28
QSPZ100N4	20-100	200-1000	100-750	334	12.7	0.8

Note

- A torque wrench tester is necessary for torque adjustment. Specify required set torque when you order. (Ex. QSPZ100N4 × 80N·m)
- Adjusting tools for QSPZ are sold separately.
- Sockets are sold separately. Refer to page 41.
- Sockets are not insulation coating.

PCL

Interchangeable Head Type Pre-Lock Torque Wrench

Direction



Interchangeable Head

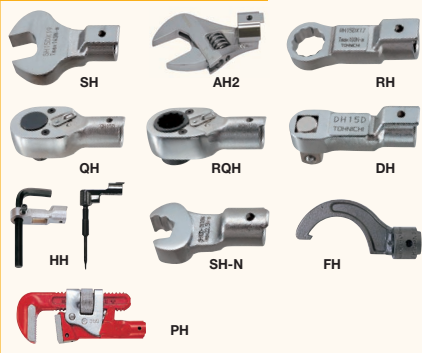

Assembly **Pre-Lock** **Interchangeable** **Graduation** **RoHS**

- Interchangeable head version of PQL
- External scale but requires hex key to set



PCL100N×15D

Tohnichi Head Size	S.I. Model	Torque Range [N·m]		Metric Model	Torque Range [kgf·cm]		American Model	Torque Range [lbf-in/lbf-ft]		Overall Length [mm]	Weight [kg]
		Min.-Max.	Grad.		Min.-Max.	Grad.		Min.-Max.	Grad.		
8D	PCL10N×8D	2-10	0.1	100PCL	20-100	1	PCL50×8D	10-50	0.5	170	0.16
	PCL15N×8D	3-15		150PCL	30-150		PCL100×8D	20-100	1		
10D	PCL25N×10D	5-25	0.25	225PCL	50-250	2.5	225PCL-A	50-200	2.5	195	0.22
	PCL50N×12D	10-50		450PCL	100-500		450PCL-A	100-400			
12D	PCL50N×15D	10-50	0.5	500PCL	100-500	5	500PCL-A	100-450	5	225	0.32
15D	PCL100N×15D	20-100		900PCL	200-1000		900PCL-A	15-75	lbf-ft	295	0.48
	PCL140N×15D	30-140	1	1400PCL	300-1400	10	1400PCL-A	30-100	1		
19D	PCL200N×19D	40-200	2	1800PCL	400-2000	20	1800PCL-A	30-150	2	435	1.3

- Note**
1. Overall length does not include interchangeable head.
 2. Use CSP model (P.19) for PH (Pipe wrench head) type interchangeable head.
 3. Interchangeable heads are optional.

Standard Accessories Hex key (for torque adjustment)

PCLLS

RoHS

- PCL style with Limit Switch output
- Ideal for torque verification (Pokayoke) assembly processes

S.I. Model	Metric Model
PCLLS25N×10D	225PCLLS
PCLLS50N×12D	450PCLLS
PCLLS50N×15D	500PCLLS
PCLLS100N×15D	900PCLLS
PCLLS140N×15D	1400PCLLS
PCLLS200N×19D	1800PCLLS

POKA Patrol (Count Checker)
CNA-4mk3

Refer to page 31.



* Sold separately

SCL

European Style Interchangeable Head Type Adjustable Torque Wrench

Direction



SCL50N-9×12

Assembly **Adjustable** **Interchangeable** **Graduation** **RoHS**

- Specialized version of CL
- Accepts DIN interchangeable head connection

S.I. Model	Torque Range [N·m]		Head Size [mm]	Overall Length [mm]	Weight [kg]
	Min.-Max.	Grad.			
SCL25N5-9×12	5-25	0.2	9×12	226	0.3
SCL50N-9×12	10-50	0.5	9×12	239	0.37
SCL100N-9×12	20-100	1	9×12	313	0.52
SCL200N-14×18	40-200	2	14×18	464	1.2

- Note**
1. Overall length does not include interchangeable head.
 2. Applicable to European style head only. Tohnichi's interchangeable heads are not available for this model.
 3. SCL25N5-9 × 12N is a yellow/black resin grip.

SCSP

European Style Interchangeable Head Type Preset Torque Wrench

Direction



SCSP50N-9×12

Assembly **Interchangeable** **Preset** **RoHS**

- Accepts DIN interchangeable head connection
- Specialized version of CSP

Model	Torque Range		Head Size [mm]	Overall Length [mm]	Weight [kg]
	[N·m]	[kgf·cm]			
	Min.-Max.	Min.-Max.			
SCSP25N-9×12	5-25	50-250	9×12	204	0.15
SCSP50N-9×12	10-50	100-500	9×12	230	0.3
SCSP100N-9×12	20-100	200-1000	9×12	302	0.45
SCSP200N-14×18	40-200	400-2000	14×18	434	1

- Note**
1. Overall length does not include interchangeable head.
 2. Applicable to European style head only. Tohnichi's interchangeable heads are not available for this model.

QSP

Ratchet Head Type Preset Torque Wrench

Direction



Assembly Preset Ratchet Head RoHS

- No external scale, Torque value set using key & tester
- Ideal for mass production application



QSP100N4

Accuracy ±3%

Model	Torque Range			Overall Length [mm]	Square Drive [mm]	Weight [kg]
	[N-m] Min.-Max.	[kgf-cm/kgf-m] Min.-Max.	[lbf-in] Min.-Max.			
		kgf-cm				
QSP1.5N4	0.3-1.5	3-15	3-13	165	6.35	0.16
QSP3N4	0.6-3	6-30	6-25			
QSP6N4	1-6	10-60	10-50			
QSP12N4	2-12	20-120	20-100	175		0.25
QSP25N3-1/4	5-25	50-250	50-200	215		0.25
QSP25N3						
QSP50N3	10-50	100-500	100-400	240	9.53	0.4
QSP100N4-3/8	20-100	200-1000	200-850	315		0.65
QSP100N4						
QSP140N3	30-140	300-1400	300-1000	380		0.7
QSP200N4	40-200	400-2000	350-1600	465	12.7	1.2
		kgf-m				
QSP280N3-1/2	40-280	4-28	350-2500	665		1.8
QSP280N3						
QSP420N	60-420	6-42	600-3600	970	19.05	3.1

- Note
1. Adjusting tools for QSP and QSP3/QSP4 are different (see Optional Accessories). Adjusting tools are sold separately.
 2. A torque wrench tester is necessary for torque setting. Specify required set torque when you order. (Ex. QSP100N4 × 80N-m)
 3. QSP200N4-QSP420N have knurled handles.

QSP Optional Accessories

Thrusting Tool (P.46)

Part #	Tool #	Applicable Model
310	A-1	1.5N-6N
311	A-2	12N, 25N
312	A-3	50N-140N
313	A-4	200N-280N
314	A-5	420N

QSP3/QSP-MH Optional Accessories

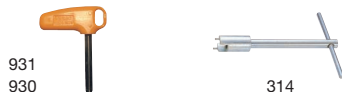

Adjusting Tool (P.46)

Part #	Applicable Model
931	QSP1.5N4-12N4, QSP25N3 (-MH)
930	QSP50N3 (-MH)-280N3 (-MH) QSP100N4 (-MH), 200N4 (-MH)
314	QSP420N



Protective Head Cover
Refer to page 46.

QSPLS

RoHS

- QSP style with Limit Switch output
- Ideal for torque verification (Pokayoke) assembly processes

Refer to page 29.

QSP-MH

Ratchet Head Type Preset Torque Wrench with Metal Handle

Direction



QSP100N4-MH

Assembly Preset Ratchet Head RoHS

- Knurled metal handle version of QSP
- Ideal for oily working conditions

Accuracy ±3%

Model	Torque Range			Overall Length [mm]	Square Drive [mm]	Weight [kg]
	[N-m] Min.-Max.	[kgf-cm] Min.-Max.	[lbf-in] Min.-Max.			
		kgf-cm				
QSP25N3-MH	5-25	50-250	50-200	215	9.5	0.25
QSP50N3-MH	10-50	100-500	100-400	240		0.4
QSP100N4-MH	20-100	200-1000	200-850	315	12.7	0.65
QSP140N3-MH	30-140	300-1400	300-1000	380		0.7

- Note
1. A torque wrench tester is necessary for torque adjustment. Specify required set torque when you order. (Ex. QSP100N4-MH × 80N-m)
 2. Adjusting tools for QSP-MH are sold separately.
 3. Sockets are sold separately. Refer to page 41.

BQSP5

Bi-Directional Type Preset Torque Wrench

Direction



BQSP100N5

Assembly Preset Ratchet Head Bi-Directional RoHS

- Click for both CW & CCW applications
- Specialized version of QSP

Accuracy ±3%

Model	Torque Range			Overall Length [mm]	Square Drive [mm]	Weight [kg]
	[N-m] Min.-Max.	[kgf-cm/kgf-m] Min.-Max.	[lbf-in] Min.-Max.			
		kgf-cm				
BQSP25N5	5-25	50-250	50-200	214	9.5	0.20
BQSP50N5	10-50	100-500	100-400	242		0.40
BQSP100N5	20-100	200-1000	200-850	314		0.63
BQSP140N5	30-140	300-1400	300-1000	379	12.7	0.73
BQSP200N5	40-200	400-2000	350-1600	462		1.3
		kgf-m				
BQSP280N5	40-280	4-28	350-2500	665	19.0	2.4
BQSP420N5	60-420	6-42	600-3600	971		3.7

- Note
1. Initial torque setting is required. Specify required set torque when you order (Ex. BQSP50N5 × 30N-m)
 2. BQSP25N5-BQSP140N5 have resin grips.
 3. BQSP200N5-BQSP420N5 have knurled handles.
 4. Adjusting tools for BQSP5 are sold separately.
 5. Sockets are sold separately. Refer to page 41.

BQSP5 Optional Accessories



Adjusting Tool (P.46)

Part #	Applicable Model
931	BQSP25N5
930	BQSP50N5-BQSP280N5
314	BQSP420N5

Torque Wrench for Assembly

CSP

Interchangeable Head Type Preset Torque Wrench

Direction



CSP Optional Accessories

Thrusting Tool (P.46)

Part #	Tool #	Applicable Model
310	A-1	1.5N-6N
311	A-2	12N, 25N
312	A-3	50N-140N
313	A-4	200N-280N
314	A-5	420N

CSP Optional Accessories

Adjusting Tool (P.46)

Part #	Applicable Model
931	CSP1.5N4-12N4, 25N3 (-MH)
930	CSP50N3 (-MH)-280N3 (-MH)
314	CSP420N

Interchangeable Head

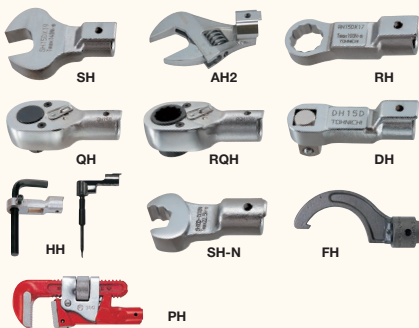

Assembly Preset Interchangeable RoHS

- Interchangeable head version of QSP
- No external scale, Torque value set using key & tester



CSP100N3x15D

Accuracy ±3%

Tohnichi Head Size	Model	Torque Range			Overall Length [mm]	Weight [kg]
		[N-m] Min.-Max.	[kgf-cm/kgf-m] Min.-Max.	[lbf-in] Min.-Max.		
8D	CSP1.5N4x8D	0.3-1.5	kgf-cm	3-15	130	0.2
	CSP3N4x8D	0.6-3	6-30	6-25	165	
	CSP6N4x8D	1-6	10-60	10-50		
	CSP12N4x8D	2-12	20-120	20-100		
10D	CSP25N3x10D	5-25	50-250	50-200	195	0.3
12D	CSP50N3x12D	10-50	100-500	100-400	215	
	CSP50N3x15D	10-50	100-500	100-400	220	
15D	CSP100N3x15D	20-100	200-1000	200-850	290	
	CSP140N3x15D	30-140	300-1400	300-1000	350	0.55
19D	CSP200N3x19D	40-200	400-2000	350-1600	430	1.0
			kgf-m			
22D	CSP280N3x22D	40-280	4-28	350-2500	625	1.4
	CSP420Nx22D	60-420	6-42	600-3600	920	2.7

- Note
1. Overall length does not include interchangeable head.
 2. Adjusting tools for CSP and CSP3/CSP4 are different. (see Optional Accessories)
 3. Interchangeable heads are optional.
 4. A torque wrench tester is necessary for torque setting. Specify required set torque when you order. (Ex. CSP100N3x15D x 80N-m)
 5. CSP200N3x19D-CSP420Nx22D have knurled handles.

CSPLS

RoHS

- CSP style with Limit Switch output
- Ideal for torque verification (Pokayoke) assembly processes

Model
CSPMS12N4x8D
CSPLS25N3x10D
CSPLS50N3x12D
CSPLS50N3x15D
CSPLS100N3x15D
CSPLS140N3x15D
CSPLS200N3x19D
CSPLS280N3x22D
CSPLS420Nx22D

POKA Patrol (Count Checker)
CNA-4mk3

Refer to page 31.



* Sold separately

CSP-MH

Interchangeable Head Type Preset Torque Wrench with Metal Handle

Direction



CSP100N3x15D-MH

Assembly Interchangeable Preset RoHS

- Knurled metal handle version of CSP
- Ideal for oily working conditions

Model	Torque Range			Overall Length [mm]	Weight [kg]
	[N-m] Min.-Max.	[kgf-cm] Min.-Max.	[lbf-in] Min.-Max.		
CSP25N3x10D-MH	5-25	50-250	50-200	195	0.2
CSP50N3x12D-MH	10-50	100-500	100-400	215	0.3
CSP50N3x15D-MH				220	
CSP100N3x15D-MH	20-100	200-1000	200-850	290	0.45
CSP140N3x15D-MH	30-140	300-1400	300-1000	350	0.55

- Note
1. A torque wrench tester is necessary for torque adjustment. Specify required set torque when you order. (Ex. CSP100N3x15D-MH x 80N-m)
 2. Adjusting tools for CSP-MH are sold separately.
 3. Sockets are sold separately. Refer to page 41.

BCSP5

Bi-Directional Interchangeable Head Type Preset Torque Wrench

Direction



BCSP100N5x15D

Assembly Preset Interchangeable Bi-Directional RoHS

- Click for both CW & CCW applications
- Specialized version of CSP

Tohnichi Head Size	Model	Torque Range			Overall Length [mm]	Weight [kg]
		[N-m] Min.-Max.	[kgf-cm/kgf-m] Min.-Max.	[lbf-in] Min.-Max.		
10D	BCSP25N5x10D	5-25	kgf-cm	50-200	195	0.20
	BCSP50N5x12D	10-50	100-500	100-400	215	0.23
15D	BCSP50N5x15D	10-50	100-500	100-400	220	
	BCSP100N5x15D	20-100	200-1000	200-850	290	0.57
19D	BCSP140N5x15D	30-140	300-1400	300-1000	350	0.62
	BCSP200N5x19D	40-200	400-2000	350-1600	430	1.2
22D			kgf-m			
	BCSP280N5x22D	40-280	4-28	350-2500	625	2.0
	BCSP420N5x22D	60-420	6-42	600-3600	920	3.7

- Note
1. Initial torque setting is required. Specify required set torque when you order. (Ex. BCSP100N5x15D x 80N-m)
 2. Overall length does not include interchangeable head. Interchangeable heads are optional.
 3. BCSP25N5x10D-BCSP140N5x15D have resin grips.
 4. BCSP200N5x19D-BCSP420N5x22D have knurled handles.
 5. Adjusting tools for BCSP5 are sold separately.
 6. Sockets are sold separately. Refer to page 41.

BCSP5 Optional Accessories

Adjusting Tool (P.46)

Part #	Applicable Model
931	BCSP25N5
930	BCSP50N5-BCSP280N5
314	BCSP420N5

Torque Wrench for Assembly

SP-H Torque Wrench for Piping Work

Direction



Assembly Preset Open End Spanner RoHS

- Made with smaller outside width to work in narrow spaces, including hydraulic piping, where current open-end type is unable to access.
- Aligned with appropriate inner widths commonly used for hydraulic piping applications.

Accuracy ±3%

Model (Body Size × Width)	Torque Range		Minimum Piping Pitch [mm]	Head Dimension (O.W. × Thickness) [mm]	Overall Length [mm]	Weight [kg]
	[N·m] Min.-Max.	[kgf·cm] Min.-Max.				
SP38N×14H	8-25	80-250	26	26.3×8	248	0.35
SP38N×19H	8-39	80-390	35	33.1×8	249	0.5
SP67N×27H	13-67	130-670	46	43.6×11	321	0.75
SP120N2×32H-MH	24-120	240-1200	54	51.6×15	392	0.75

- Note
1. Confirm the minimum piping pitch before you order.
 2. A torque wrench tester is necessary for torque setting. Specify required set torque when you order. (Ex. SP38N×14H × 25N·m)
 3. SP120N2×32H-MH is a knurled handle. Others are resin handles.

Thrusting Tool (P.46)

Part #	Tool #	Applicable Model
312	A-3	SP38N, 67N-H
930	-	SP120N2×32H-MH

SP-N/SP-N-MH

Direction



Notched Head Type
Preset Torque Wrench



Assembly Preset Notched Head RoHS

- Notch creates speed in tightening process.
- Ideal for brake lines

Accuracy ±3%

Model (Body Size × Width)		Torque Range		Head Dimension		Overall Length [mm]	Weight [kg]
SP-N	SP-N-MH	[N·m] Min.-Max.	[kgf·cm] Min.-Max.	O.W. × Thickness [mm]	Head Shape		
SP19N-1×10N	SP19N-1×10N-MH			24×12	A	215 (211)	0.2
SP19N-3×10N	SP19N-3×10N-MH			24×15			
SP19N-4×10N	SP19N-4×10N-MH	3.5-19	35-190	24×10	B		
SP19N-5×10N	SP19N-5×10N-MH			24×15			
SP19N-9×10N	SP19N-9×10N-MH			24.5×10			
SP38N×14N	SP38N×14N-MH	8-38	80-380	35×8	A	253.5 (248.5)	0.35

- Note
- A torque wrench tester is necessary for torque setting. Specify required set torque when you order. (Ex. SP19N-1×10N × 15N·m)

SPLS-N/SPLS-N-MH

- SP-N style with Limit Switch output
- Ideal for torque verification (Pokayoke) assembly processes

Accuracy ±3%

Model (Body Size × Width)		Torque Range		Head Dimension		Overall Length [mm]	Weight [kg]
SP-N	SP-N-MH	[N·m] Min.-Max.	[kgf·cm] Min.-Max.	O.W. × Thickness [mm]	Head Shape		
SPLS19N-1×10N	SPLS19N-1×10N-MH			24×12	A	215 (211)	0.2
SPLS19N-3×10N	SPLS19N-3×10N-MH			24×15			
SPLS19N-4×10N	SPLS19N-4×10N-MH	3.5-19	35-190	24×10	B		
SPLS19N-5×10N	SPLS19N-5×10N-MH			24×15			
SPLS19N-8×10N	SPLS19N-8×10N-MH			24×12			
SPLS19N-9×10N	SPLS19N-9×10N-MH			24.5×10	A		

- Note
- The curl cord length of SPLS19N-8×10N is about 5m in full extension. Others are extended to about 2m in full extension.

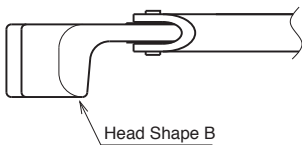
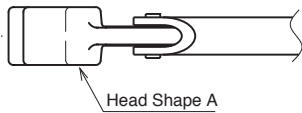

NSP100CNx8

Direction



Break-Over Torque Wrench



Assembly Preset Open End Spanner Break-Over RoHS

- Ideal for SMA connector tightening
- 90 degree of “breaking” upon reaching the set torque to reduce the possibility of over-torque

Accuracy ±5%

Model (Body Size × Width)	Torque Range	Head Dimension [mm]	Overall Length [mm]	Weight [kg]
	[cN·m] Min.-Max.			
NSP100CN×8	50-100	16×4	128	0.33

- Note
- A torque wrench tester is necessary for torque setting. Specify required set torque when you order.



NSP Optional Accessories

Thrusting Tool (P.46)

Part #	Applicable Model
310	NSP100CN×8

QSPCA Slip Type Torque Wrench

Direction



QSPCA6N



QSPCA30N



QSPCA70N

QSPCA Optional Accessories



931
930

Adjusting Tool (P.46)

Part #	Applicable Model
931	QSPCA6N, QSPCAMS6N QSPCA12N, QSPCAMS12N
930	QSPCA30N, QSPCALS30N QSPCA70N, QSPCALS70N QSPCAFH30N, QSPCAFH70N

Assembly Preset Ratchet Head Slip Type RoHS

- Cam action mechanism generates a 45 degree "slip" action.
- No torque variation by gripping point
- Conforms to the Electrostatic Discharge (ESD) standard

Model	Torque Range			Overall Length [mm]	Square Drive [mm]	Weight [kg]	Accuracy [%]
	Min.-Max. [N-m]	Min.-Max. [kgf-cm]	Min.-Max. [lbf-in]				
QSPCA6N	2-6	20-60	20-50	197	6.35	0.33	±6%
QSPCA12N	4-12	40-120	40-100				
QSPCAMS6N	2-6	20-60	20-50	267	9.53	0.45	±6%
QSPCAMS12N	4-12	40-120	40-100				
QSPCA30N	10-30	100-300	90-270	346	1.24	0.64	±4%
QSPCA70N	20-70	200-700	180-620	267			
QSPCALS30N	10-30	100-300	90-270	346	0.81	1.41	
QSPCALS70N	20-70	200-700	180-620	346			

- Note
1. A torque wrench tester is necessary for torque adjustment. Specify required set torque when you order. (Ex. QSPCA6N × 5N-m)
 2. Adjusting tools for QSPCA are sold separately.
 3. Limit Switch specifications are AC30V below 1A, DC30V below 1A.
 4. Standard curl cord can be extended to about 2m in full extension.
 5. Female connector for LS cable is sold separately. Part# WA5219K.
 6. QSPCA70N and QSPCALS70N have knurled handles.

QSPCAMS/ QSPCALS

RoHS

- QSPCA style with Limit Switch output
- Ideal for torque verification (Pokayoke) assembly processes



QSPCAMS6N



QSPCAMS12N



QSPCALS30N



QSPCALS70N

POKA Patrol (Count Checker) CNA-4mk3

Refer to page 31.



* Sold separately

QSPCAFH

RoHS

- QSPCA style with wireless error-proofing (Pokayoke) torque system

Model
QSPCAFH30N
QSPFAFH70N



QSPCAFH30N



QSPCAFH70N

Note Refer to page 30 for condition of wireless equipment in each country.

YCL2 Two Step Motion Torque Wrench

Direction



YCL90N2x15D

Assembly Adjustable Interchangeable Graduation Two Step Motion RoHS

- Two step motion prevents over-torque.
- Suitable for assembly of critical parts
- Easy torque setting by graduation
- Heads types can be easily exchanged.

Tohnichi Head Size	S.I. Model	Torque Range [N-m]		Metric Model	Torque Range [kgf-cm]		American Model	Torque Range [lbf-in/lbf-ft]		Max Hand Force [N]	Effective Legthe [mm]	Overall Length [mm]	Weight [kg]
		Min.-Max.	Grad.		Min.-Max.	Grad.		Min.-Max.	Grad.				
10D	YCL10N2x10D	5-10	0.10	100YCL2	50-100	1	YCL100I	lbf-in	lbf-in	46.5	215	245	0.35
	YCL20N2x10D	10-20	0.20	200YCL2	100-200	2	YCL200I	100-200	2	93			
12D	YCL40N2x12D	20-40	0.25	400YCL2	200-400	2.5	YCL400I	200-400	2.5	145.5	275	309	0.53
	YCL70N2x12D	35-70	0.50	700YCL2	350-700	5	YCL600I	300-600	5	254.5			
15D	YCL90N2x15D	45-90	0.25	900YCL2	450-900	2.5	YCL750I	400-750	2.5	236.8	380	414	1.05
	-	-	-	-	-	-	YCL1000I	600-1000	5	-			
19D	YCL140N2x15D	70-140	0.50	1400YCL2	700-1400	5	YCL100F	45-100	0.5	368.4	579	607	1.75
	YCL180N2x19D	90-180	-	1800YCL2	900-1800	-	-	-	-	310			
-	-	-	-	-	-	-	YCL150F	80-150	0.5	-			

Note Not for inspection purposes

CPT-G

PRO TORK
(Digital Torque
Wrench for
Tightening)

Direction



PRO TORK™



CPT50×12D-G



CPT100×15D-G

How to Order:

[Ex. 1] CPT100×15D-G-SET

* "Set" model version
(with standard accessories)

[Ex. 2] CPT200×19D-G

* "Torque Wrench Only" version
(without standard accessories)

CPT-G Optional Accessories



844

Carrying Case (For "Set" model only)

Part #	Applicable Model Dimension [mm]	Weight [kg]
844	CPT20×10D-G to CPT100×15D-G (H170 × W500 × D100)	1.0
845	CPT200×19D-G, CPT280×22D-G (H170 × W740 × D100)	1.6



585



Connecting to CPT-G

Connecting Cable

Part #	Applicable Model
585	CPT-G → PC (D-Sub 9 Pin Female)

Data Processing Software

Model
EXCEL RECEIVER

Assembly Digital Interchangeable Signal Battery RoHS

- Highly responsive to the applied torque value with indicator display
- Equipped with bright LED lamp indicating current torque level
- 5 changeable units of measure through keypad set up
- Data memory, torque set registration and output functions

"Torque Wrench Only" Models

Accuracy ±3%

Model	Torque Range										Overall Length [mm]	Weight [kg]
	[N·m]		[kgf·cm]		[kgf·m]		[lbf·in]		[lbf·ft]			
	Min.-Max.	1 digit	Min.-Max.	1 digit	Min.-Max.	1 digit	Min.-Max.	1 digit	Min.-Max.	1 digit		
CPT20×10D-G	4-20	0.02	40-200	0.2	0.4-2	0.002	36-180	0.2	3-14.5	0.02	280.5	0.63
CPT50×12D-G	10-50	0.05	100-500	0.5	1-5	0.005	100-440	0.5	7.5-36	0.05	282.5	0.65
CPT100×15D-G	20-100	0.1	200-1000	1	2-10	0.01	200-880	1	15-73	0.1	384.5	0.85
CPT200×19D-G	40-200	0.2	400-2000	2	4-20	0.02	360-1700	0.2	30-150	0.2	475.5	1.37
CPT280×22D-G	56-280		560-2800		5.6-28		500-2400		42-200		591.5	1.76

- Note**
1. "Torque Wrench Only" version is provided in basic carton product box and does not include TQH Head, Batteries, Storage Case, or Product Box.
 2. "Overall Length" does not include the length of interchangeable head TQH.
 3. "Weight" does not include the weight of interchangeable head TQH and batteries.
 4. Approx. 230 different types of interchangeable heads are available and sold separately. Refer to Tohnichi's Torque Handbook or Product Catalog for additional information.

"Set" Models (including Accessories)

Model	Standard Accessory				
	Ratchet Head		Battery	Storage Case	Product Box
	Model	Sq. Drive [mm]			
CPT20×10D-G-SET	TQH10D	9.5	AA Alkaline	Small	Small
CPT50×12D-G-SET	TQH12D		Battery		
CPT100×15D-G-SET	TQH15D	12.7	(2pcs)	Large	Large
CPT200×19D-G-SET	TQH19D				
CPT280×22D-G-SET	TQH22D	19.0			

Note Recommendation: Use 2xAA Ni-MH batteries for longer continuous use.

CPT-G Common Specifications

Accuracy	±3% of indicated value
Tightening Direction	Clockwise/Counter clockwise
Display/Character Height	14 segment LCD 6 digits/7mm
	7 segment LCD 4 digits/3mm
Battery Life Indicator	4 steps
Number of Data Memory	50
Torque Setting Memory	Preset Tightening mode: 10 torque values to register
	Judgment Tightening mode: Up to 10 values of each Upper/Lower/Tightening direction
Basic Function	Auto power off (3 minutes)
	Auto memory/Reset
	Auto zero
	Over torque alarm
Power	AA battery × 2pcs
Continuous Use	Approx. 40 hours
Temperature in Use	0-40 Celsius below 85%RH (no condensation)

Several different tightening modes available to cater to a variety of applications. Quick and accurate tightening while preventing errors.

Modes include:

[Preset Tightening Mode](#), [Judgment Tightening Mode](#), [Peak/Run Modes](#)

* Retightening/loosening torque is performed in the Peak Mode.

Preset Tightening Mode: Allows user to set the target torque with specific % of torque allowable beyond target, then the red LED moves towards the right to indicate the level of the applied torque. When it reaches the target torque range, the blue LED blinks and the buzzer signals tightening completion.

Judgment Tightening Mode: Allows user to set judgment ranges for lower/upper limit in the tightening operation. Upon tightening completion a judgment is made as torque value is stored in the memory.



Display example 1:
Preset Tightening Mode
(Red LED shows the level of the applied torque)



Display example 2:
Judgment Tightening Mode
(As torque is being applied prior to completion)



Display example 3:
Judgment Tightening Mode
(The case of exceeding target torque range)

CTA2 Digital Torque and Angle Wrench

Direction



- Assembly
- Digital
- Interchangeable
- Signal
- Re-Chargeable
- RoHS

- Snug and angle setting functions
- Buzzer/Light alerts to snug torque and angle completion
- Angle mode activates automatically, once snug torque is achieved.

Accuracy ±1%

S.I. Model	Torque Range [N-m]		Metric Model	Torque Range [kgf-cm/kgf-m]		American Model	Torque Range [lbf-in/lbf-ft]		Angle Measuring Range		Angle Accuracy	Overall Length [mm]	Weight [kg]
	Min.-Max.	1 digit		Min.-Max.	1 digit		Min.-Max.	1 digit	Min.-Max.	1 digit			
CTA50N2x12D	(2.5) 10-50	0.05	CTA50N2x12D-M	(25) 100-500	0.5	CTA50N2x12D-I	(25) 100-450	0.5			±2° +1 digit (Angular velocity is 30°/s - 180°/s when the bolt turned to 90°)	282	0.58
CTA100N2x15D	(5) 20-100	0.1	CTA100N2x15D-M	(50) 200-1000	1	CTA100N2x15D-I	(50) 200-900	1				384	0.63
	-	-	-	-	-	CTA100N2x15D-F	(3.8) 15-75	0.1	0-999°	1°		384	0.63
CTA200N2x19D	(10) 40-200	0.2	CTA200N2x19D-M	(100) 400-2000	2	CTA200N2x19D-F	(7.6) 30-150	0.2			475	0.78	
CTA360N2x22D	(18) 72-360	0.4	CTA360N2x22D-M	(180) 720-3600	4	CTA360N2x22D-F	(13) 52-260	0.4			713	1.13	
CTA500N2x22D	(25) 100-500	0.5	CTA500N2x22D-M	(2.5) 10-50	0.05	CTA500N2x22D-F	(18) 72-360	0.5			949	4.00	
CTA850N2x32D	(43) 170-850	1	CTA850N2x32D-M	(4.3) 17-85	0.1	CTA850N2x32D-F	(31) 124-620	1			1387	5.14	

- Note**
1. The value shown in () shows the lowest snug torque. Accuracy cannot be guaranteed for snug torque set beyond the operative torque range.
 2. Overall length does not include interchangeable head.
 3. PH (Pipe wrench head) type interchangeable head cannot be used with this model.
 4. CTA500N2x22D and CTA850N2x32D have knurled handles.

Standard Accessories Battery pack/BP-5, QH interchangeable head (P.44), Quick battery charger/BC-3-G (100-240V), Application PC software, cable/584

CTA2 Optional Accessories

Battery Pack (P.47)

Model
BP-5

Quick Battery Charger (P.47)

Model	Voltage
BC-3-G	100-240V

Printer (P.67)

Model
EPP16M3

Connecting Cable (P.47)

Part #	Applicable Models
575	CTA2 → PC, EPP16M3 (D-SUB 9 Pin Female)
584	CTA2 → PC (USB A Type)

- Note**
1. () shows pin shape of the connecting cables.
 2. Contact Tohnichi for other types of connecting cables.

Carrying Case (P.46)

Model	Dimension [mm]	Weight [kg]
846	50N2x12D, 100N2x15D [H170 x W500 x D100]	1.0
847	200N2x19D, 360N2x22D [H170 x W740 x D100]	1.6

CTA2, Single Spindle Mode and Production Mode

CTA2 Features 2 Modes: Single Spindle and Production Modes

Single Spindle Tightening Mode: For angle method tightening of a single bolt tightening with snug torque, tightening angle and tightening angle upper limit settings.

Production Tightening Mode: For angle method tightening of multi spindle, with tightening torque, snug torque, 1st, 2nd and 3rd tightening angle, each upper limited angle, the numbers of spindles are registered.

By using the included software package, various settings can be done through the PC and transferred to the wrench with the final tightening values being sent back to an Excel spreadsheet.



Single Mode Setting Display

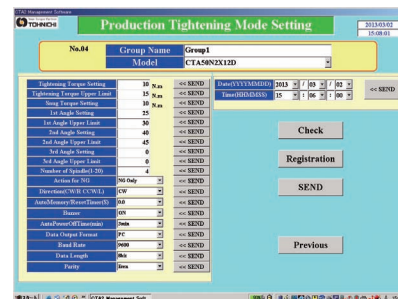

Production Mode Setting

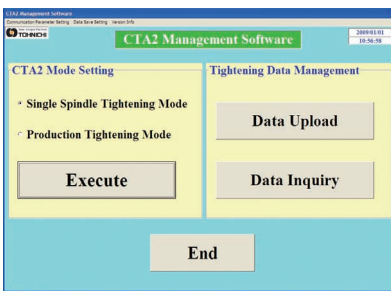

Main Menu

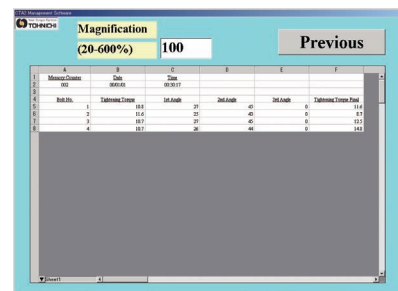

Production Mode Data Display

CTA2 Common Specifications

Data Memory	999 data (Tightening torque, 1st angle value, 2nd angle value and final torque value)
Measurement Mode	Single spindle/Production mode
Data Output	RS232C compliant
Zero Adjustment	Auto zero (Angle, Torque)
Power	Ni-MH rechargeable battery
Continuous Use	Approx. 20 hours with fully charged (8 hours by 1 hour recharging)
Recharging Time	Approx. 3.5 hours
Temperature in Use	0-40 Celsius no condensation
Other Functions	Snug torque, Tightening torque, Max. tightening torque, 1st, 2nd, 3rd angle, 1st, 2nd, 3rd max. angle, Number of bolts, Auto reset, Judgment, Setting through PC, Battery indicator

DWQL Analog Torque with Digital Angle Module

Assembly Digital Ratchet Head Graduation Signal RoHS



DWQL100N

- Easily apply snug torque with "click" followed by angle with integrated digital angle display.
- Digital angle starts once snug torque setting is achieved.
- Correct angle is calculated and shown even when ratcheting feature is used.

Accuracy ±3%

S.I. Model	Torque Range [N-m]		Angle Range		Angle Accuracy	Overall Length [mm]	Weight [kg]
	Min.-Max.	Grad.	Min.-Max.	1 digit			
DWQL50N	(5) 10-50	0.5			±2°+1digit (Angular velocity is 30°/s-180°/s when the bolt is turned to 90°.)	260	0.62
DWQL100N	(10) 20-100	1				335	0.86
DWQL140N	(25) 30-140					400	1.00
DWQL200N	(30) 40-200		0-999°	1		490	1.6
DWQL280N	(30) 40-280	2				695	2.2
DWQL420N	(40) 60-420					995	3.6

- Note**
1. The capacity values in the () are minimum setting values for snug torque, but these values are not within guaranteed accuracy range.
 2. A value in the () might not be exact same when purchased M-DW is installed on LS torque wrench.
 3. Certificates of calibration for both torque and angle are included.
 4. Prior to use, confirm final applied torque value will not exceed max torque of the tool.



* M-DW shows 20° from snug torque.

M-DW Convert torque wrench with limit switch to angle torque wrench by installing M-DW.

Digital Angle Module

Model	Description
M-DW	Angle module for torque wrench with limit switch

- Note**
1. M-DW can be installed on torque wrench with limit switch except for the following models: QSPCAL5, ALS, ACLS, MS type torque wrench, SPLS8N, and RSPLS8N. Refer to page 29.
 2. Operate within torque range of installed torque wrench.
 3. Certificate of angle calibration is attached.

M-DW Specifications

Range of Angle	0-999°
1 digit	1°
Angle Accuracy	±2°+1digit (Angular velocity is 30°/s-180°/s when the bolt is turned to 90°.)
Display	7 segments LED, 3 digits/Character height 10mm
Continuous Operation	Approx. 60 hours
Environment	0-40°C Below 85%RH (no condensation)
Standard Accessories	Limit switch with connector 1 pc. Screw & Washer: 2 pcs. per each Operating instruction, AAA battery: 1 pc.
Weight	0.12kg

- Torque wrench with Limit Switch is converted to digital angle torque wrench.

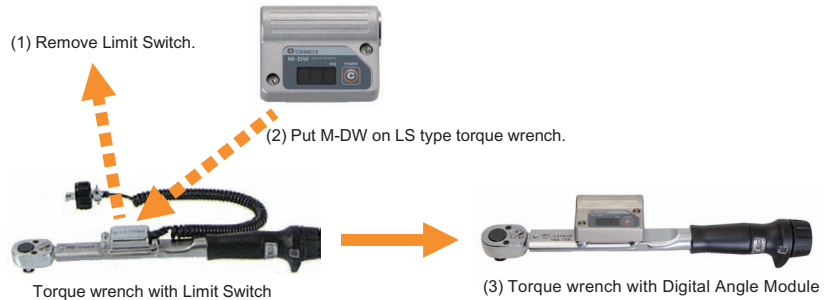

WQL Analog Torque and Angle Wrench

Direction

Assembly Dial Indicating Ratchet Head Graduation Angle Direct Reading RoHS



WQL100N4

- Includes built-in protractor with flexible arm
- Specialized version of QL

Accuracy ±3%

S.I. Model	Torque Range [N-m]		Metric Model	Torque Range [kgf-cm/kgf-m]		American Model	Torque Range [lbf-in/lbf-ft]		Square Drive [mm]	Overall Length [mm]	Angle Scale	
	Min.-Max.	Grad.		Min.-Max.	Grad.		Min.-Max.	Grad.			Max.	Grad.
WQL50N	(5) 10-50	0.5	450WQL3	kgf-cm	kgf-m	450WQL3-A	lbf-in	lbf-in	9.5	260		
WQL100N4	(10) 20-100	1	900WQL4	(100) 200-1000	1	900WQL4-A	(40) 100-400	5	12.7	345	360°	2°
WQL200N4	(30) 40-200		1800WQL4	(300) 400-2000	2	1800WQL4-A	(20) 30-150	2		495		
WQL280N	(30) 40-280	2	2800WQL3	kgf-m	kgf-m	2800WQL3-A	(20) 30-200	2	19.0	695		
WQL420N	(40) 60-420		4200WQL2	(4) 6-42	0.2	4200WQL2-A	(30) 60-300	3		975		

- Note**
1. The capacity value in the () are minimum setting value for snug torque, but this value is not within guaranteed accuracy range.
 2. WQL Models are supplied upon request.

MPQL/MQL

Direction Marking Torque Wrench

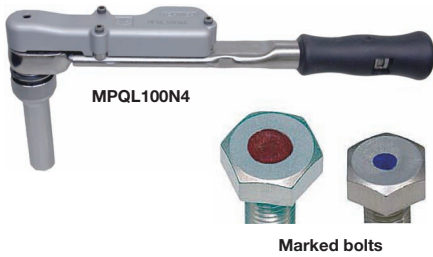

Assembly **Pre-Lock** **Ratchet Head** **Graduation** **Quick Drying Ink** **RoHS**

- Mechanism marks bolt as torque is achieved.
- Requires special socket, marker and ink

Accuracy ±3%

S.I. Model	Torque Range [N·m]		Metric Model	Torque Range [kgf·cm/kgf·m]		American Model	Torque Range [lbf·in/lbf·ft]		Overall Length [mm]	Weight [kg]
	Min.-Max.	Grad.		Min.-Max.	Grad.		Min.-Max.	Grad.		
MPQL50N	10-50	0.5	450MPQL	100-500	5	450MPQL-A	100-400	5	246	0.7
MPQL100N4	20-100	1	900MPQL4	200-1000	10	900MPQL4-A	15-75	lbf-in	320	0.95
MPQL140N	30-140		1400MPQL	400-1400		1400MPQL-A	30-100	lbf-ft		
MPQL200N4	40-200	2	1800MPQL4	400-2000	20	1800MPQL4-A	30-150	lbf-in	418	1.8
MQL280N	40-280		2800MQL3	4-28		0.2	2800MQL3-A	30-200		

Note Please choose a Tohnichi's original socket with width which matches your bolt size, and order it together with the torque wrench. Standard sockets can not be used.

Standard Accessories Hex key (for torque adjustment)

MQSP

Marking Torque Wrench

Direction



Assembly **Preset** **Ratchet Head** **Quick Drying Ink** **RoHS**

- Mechanism marks bolt as torque is achieved.
- Preset style of MPQL

Accuracy ±3%

Model	Torque Range			Overall Length [mm]	Weight [g]
	[cN·m]	[kgf·cm]	[lbf·in]		
	Min.-Max.	Min.-Max.	Min.-Max.		
MQSP50N	10-50	100-500	100-400	240	0.7
MQSP100N	20-100	200-1000	100-750	315	1.0
MQSP140N	30-140	400-1400	300-1000	380	1.1
MQSP200N	40-200	400-2000	350-1600	465	1.8

- Note**
1. Please choose a Tohnichi original socket with width matches your bolt size, and order it together with the torque wrench. Standard sockets can not be used.
 2. A torque wrench tester is necessary for torque adjustment. Specify required set torque when you order. (Ex. MQSP50N × 30N·m)
 3. Adjusting tools for MQSP are sold separately.
 4. MQSP200N has knurled handles.

CMQSP

Marking Torque Wrench

Direction



Assembly **Preset** **Ratchet Head** **Quick Drying Ink** **RoHS**

- Preset style marking torque wrench for hex screws
- Mechanism marks side of bolt and work piece.

Accuracy ±3%

S.I. Model	Torque Range [N·m]	Width Across Flat	Overall Length [mm]	Weight [kg]
	Min.-Max.	Min.-Max.		
CMQSP-M6	5-25	5	241	0.85
CMQSP-M8	10-50	6		0.85
CMQSP-M10	20-100	8	320	1.13
CMQSP-M12	30-140	10	380	1.13

Note A torque wrench tester is necessary for torque setting. Specify required set torque when you order. (Ex. CMQSP-M10 × 50N·m)

Standard Accessories 2 x Hex wrench (including 1 spare), Marker head, Marker case, Hex wrench position adjustment tool

CMQSP Optional Accessories

Bit

Part #	Description
724	CMQSP-M6 Bit
725	CMQSP-M8 Bit
726	CMQSP-M10 Bit
727	CMQSP-M12 Bit

Marker Head

Part #	Description
792	Marker Head for CMQSP

Refill Ink and Solvent

Part #	Description
776	White Ink
777	Yellow Ink
794	Solvent

CMQSP Adjusting Adapter

Part #	Description	Applicable Tester
811	CMQSP-M6 Adapter	DOTE20N3-G, 50N3-G, 100N3-G
812	CMQSP-M8 Adapter	
813	CMQSP-M10 Adapter	DOTE200N3-G, 500N3-G
814	CMQSP-M12 Adapter	

CMQSP Adjusting Pole Holder

Part #	Applicable Model	Applicable Tester
815	CMQSP-M6, M8 Pole Holder	DOTE20N3-G, 50N3-G, 100N3-G
816	CMQSP-M10, M12 Pole Holder	DOTE200N3-G, 500N3-G

Note A torque wrench tester, Tohnichi's Adjusting Adapter, and Pole Holder are necessary for CMQSP torque adjustment.

CMQSP Adjusting Tool (P.46)

Part #	Applicable Model
930	CMQSP-M6, M8, M10, M12

MPQL/MQL/MQSP Optional Accessories

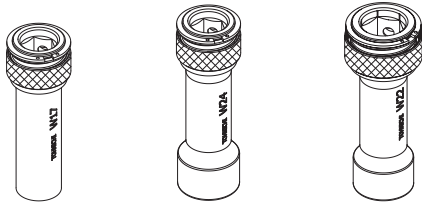

No.1700
No.1701
No.1702
No.1703
No.1712
No.1713
No.1714

No.1704
No.1705
No.1706
No.1707
No.1709
No.1710
No.1715
No.1716
No.1717

No.1720
No.1721
No.1722
No.1723

Socket

Model	Part #	Width Across Flat [mm]	Length H [mm]	Outside Width ϕ [mm]	Applicable Torque T-max [N-m]	Applicable Model
Socket 4MH-10	1700	10	100	17.5	25	MQSP/MPQL 50N-200N4
Socket 4MH-12	1701	12		20.5	35	
Socket 4MH-13	1702	13		21.5	40	
Socket 4MH-14	1703	14		22.5	60	
Socket 4MH-16	1704	16		25	70	
Socket 4MH-17	1705	17	105	28	110	
Socket 4MH-18	1706	18		29	120	
Socket 4MH-19	1707	19		30	170	
Socket 4MH-22	1709	22		30	190	
Socket 4MH-24	1710	24		32.8	200	
Socket 6MH-22	1720	22	110	32	255	MQL280N
Socket 6MH-24	1721	24		34.5	255	
Socket 6MH-27	1722	27		38.5	255	
Socket 6MH-30	1723	30		42	280	

Inch Size Socket

Model	Part #	Width Across Flat		Tmax [lbf-in] (N-m)	Length H [mm]	Outside Width ϕ [mm]	Applicable Model
		[inch]	[mm]				
Socket 4MH-7/16	1712	7/16	11.113	300(35)	100	20	MQSP/MPQL 50N-200N4
Socket 4MH-1/2	1713	1/2	12.7	400(45)		21	
Socket 4MH-9/16	1714	9/16	14.288	700(80)		23	
Socket 4MH-5/8	1715	5/8	15.875	800(90)	105	25.5	
Socket 4MH-11/16	1716	11/16	17.463	1000(120)		28.5	
Socket 4MH-3/4	1717	3/4	19.05	1500(170)		30	

Note Refill Ink and solvent are classified as hazardous material in Aviation law.

Marker Head

Model	Part #	Color
Marker Head MK53RB	1780	Red, Blue
Marker Head MK53WY	1782	White, Yellow
Marker Head MK93RB	1783	Red, Blue
Marker Head MK93WY	1785	White, Yellow

- Note**
- Use W10-W16 sockets for MK53.
 - MK53 types have 5mm marking diameter.
MK93 types have 9mm marking diameter.
 - Select a proper marking color for adapting to your bolt surface type.
 - Alkaline blackening (black finishing) → White, Yellow
 - Chromate coating, Trivalent chrome, Stainless steel → Blue, Red, White, Yellow.
 - Marker heads are not filled the ink.
Select your necessary ink at the same time.

Refill Ink and Solvent

Model	Part #	Color
Refill Ink R	1770	Red
Refill Ink B	1771	Blue
Refill Ink W	776	White
Refill Ink Y	777	Yellow
Solvent	794	For White and Yellow

Note Solvent for red and blue inks is not available.

Replacement Tips

Model	Part #	Color
Felt tip for MK53RB	1775	Red, Blue
Felt tip for MK53WY	775	White, Yellow
Felt tip for MK93RB	1776	Red, Blue
Felt tip for MK93WY	1777	White, Yellow

Note Sold in pack of ten tips.

Extension Bar

Model	Part #	Applicable Model
MPQL Extension Bar 50mm	1749	MPQL50N-200N4
MPQL Extension Bar 100mm	1748	MQSP50N-200N
MQL Extension Bar 50mm	1752	MQL280N

MPQL/MQSP Torque Adjusting Adapter

Model	Part #	Applicable Model	Applicable Tester
MQSP 3/8-17 Adapter	817	MPQL50N MQSP50N	DOTE50N3
MQSP 1/2-17 Adapter	818	MPQL100N4-200N4 MQSP50N-200N	DOTE100N3 DOTE200N3

MQSP Adjusting Tool

Part #	Applicable Model
930	MQSP50N, 100N, 200N

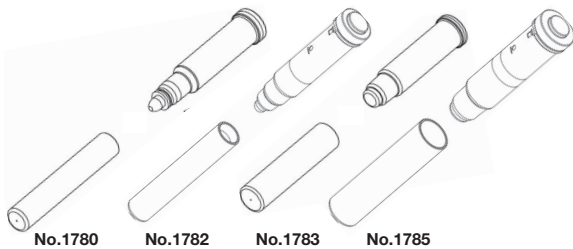

No.1780 No.1782 No.1783 No.1785

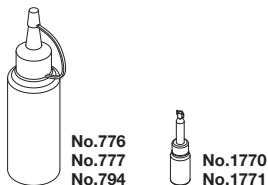

No.776
No.777
No.794
No.1770
No.1771

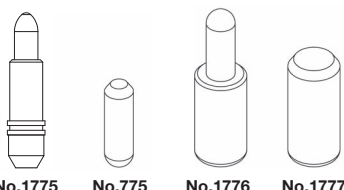

No.1775 No.775 No.1776 No.1777

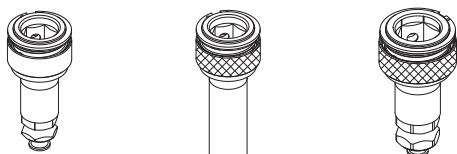

No.1749 No.1748 No.1752

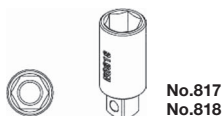

No.817
No.818



No.930

Pokayoke, Error-Proofing System

Counter Method

LS
(Wired)

Examples) QL/QLE2 (P.12), CL/CLE2 (P.13), TiQL/TiQLE (P.15), PQL (P.16), QRSP (P.15), PCL (P.17), QSP (P.18), QSPCA (P.22), CSP (P.19), SP-SP2/-MH (P.20), RSP-RSP2/-MH (P.20), SP-N/SP-N-MH (P.21), AUR (P.48), A/AC2 (P.50)



Control the number of tightening to eliminate missed tightening



CNA-4mk3
(Count Checker)

FH
(Wireless)



R-FH256
Receiver

Examples) FH transmitter (P.30) mounted on torque wrench such as QL
Equipped with FH functions such as HATFH (P.48)
Note : Refer to page 30 for condition of wireless equipment in each country.

Marking Method (P.26)



MPQL100N4

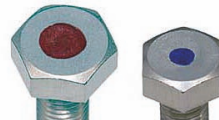

CMQSP-M8



Visually check the bolt marked to recognize torque tightening completion

FH256MC

Radio Frequency Torque Wrench System

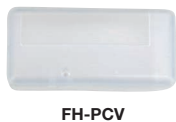
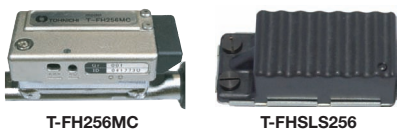

- Wireless error-proofing (Pokayoke) torque system
- FHSS technology with universal 2.4GHz frequency band
- Wrench ID transfer functions to establish bolt tightening traceability
- Easily change frequency with wireless setting box (optional)

FH Torque Wrench Examples

QLFH/QLFHLSL FH transmitter mounted on QL	
S.I. Model	
QLFH25N5	
QLFH50N	
QLFH100N4	
QLFH140N	
QLFH200N4	

SPFH/SPFHLSL FH transmitter mounted on SP	
Model	
SPFH38N×14	
SPFH38N×27	

QSPCAFH/QSPCAFHLSL FH transmitter mounted on QSPCA	
Model	
QSPCAFH30N	
QSPCAFH70N	

Transmitter RoHS

Model	Description	Dimension [mm]
T-FH256MC	Transmitter for FH256MC	W36 × D80 × H18
T-FHLS256	Transmitter for LS type wrench	W32.4 × D56 × H22.3

Note T-FHLS256 is a wireless transmitter module to be installed on LS type torque wrenches.

Receiver RoHS

All kinds of frequency groups (256 kinds) can be set in one receiver.

Model	Specification
R-FH256	Output: No-Voltage contact output (1a), RS232C Size: W150 × D210 × H51 (mm), Weight 1.7kg Power: AC100V-240V, 47-63Hz

Standard Accessories Dipole antenna

Setting Box RoHS

Wireless setting device for FH transmitter and receiver

Model	Specification
SB-FH256	Input: RS232C, Power: DC9V

Standard Accessories Dipole antenna

Multi I/O Box RoHS

Manage 4 tightening signals from receiver and output to external device

Model	Applicable Model	Specification
I/O-FH256	R-FH256	Output: No-Voltage contact output (1a) × 4, Power: AC100-240V

Antenna Extension Cord

Extends antenna from R-FH256 receiver to improve communication conditions

Model	Applicable Model	Specification
FH-COD	R-FH256	Cable Length: Approx. 9.5m

Magnetic Antenna Holder

Use this to fix the position of extended antenna

Model	Applicable Model	Specification
FH-MHD	R-FH256	Cable Length: Approx. 1.5m

Protective Cover

Put it on the transmitter (T-FH256MC and T-FHLS256) to protect from physical damage.

Model	Applicable Model	Specification
FH-PCV	T-FH256MC	Material: Silicon Resin
FHLS-PCV	T-FHLS256	

Note

1. Transmission distance 10-20 meters
2. Refer to base model series for torque ranges and wrench specs.
3. Refer to condition of wireless equipment in each country.

Conditions of wireless equipment certification acquisition

Country	Authority	Acquisition condition
Japan	TELEC	FH256MC, FHLSL, FMA, FHD, FHDS, CEM3-G-BT, CEM3-G-BTM, ST2-BT, ST3-G-BT, STC2-G-BT
United States	FCC	FH256MC, FHLSL, FMA, FHD, FHDS, CEM3-G-BT, CEM3-G-BTM, ST2-BT, ST3-G-BT, STC2-G-BT
Canada	IC	FH256MC, FHLSL, FMA, FHD, FHDS, CEM3-G-BTM, ST3-G-BT, STC2-G-BT
EU	CE	FH256MC, FHLSL, FHD, CEM3-G-BT, CEM3-G-BTM, ST3-G-BT, STC2-G-BT
China	SRRC	FH256MC, FHLSL, FHD, CEM3-G-BT, CEM3-G-BTM
Thailand	NTC	FH256MC, FHLSL, FHD, FHDS, CEM3-G-BT, CEM3-G-BTM, ST2-BT, ST3-G-BT, STC2-G-BT
Malaysia	SIRIM	FH256MC, FHLSL, FHD, FHDS
Indonesia	SDPPI	FH256MC, FHLSL, FHD, FHDS
South Korea	KCC	FH256MC, FHDS
Taiwan	NCC	FH256MC, FHLSL, FHD, FHDS
Russia	FSB	FH256MC, FHD, FHDS, CEM3-G-BT
India	WPC	FH256MC
South Africa	ICASA	FH256MC

Note

1. All Tohnichi wireless equipment is authorized in Mexico and Vietnam.
2. Contact Tohnichi for other countries.

FMA

*the United States and Canada Only

Radio Frequency Torque Wrench System



R-FMA

- 900 MHz frequency wireless error-proofing torque system
- FHSS Technology decreases interference and increases signal capacity
- Transmission Distance 10-20 Meters (30-60 Feet)
- Easily change frequency with SB-FMA Controller Box

Transmitter, Receiver, and Setting Box

Model	Description	Specifications
T-FMA	Transmitter for R-FMA	900MHz (902.5MHz to 9027.5MHz) 250kHz interval, 80CH, Approx. 10 - 20m / 30 - 60 feet operating distance
R-FMA	Receiver for T-FMA	
SB-FMA	Setting box	

Note

1. Radio frequency communication errors may be caused by noise or a shield placed between the transmitter and receiver. In addition, radio waves reflected by metal, concrete, etc. may interfere with radio waves directly sent to the antenna of the receiver and dead point occurs, resulting in communications errors.
2. Available only in the United States and Canada.

CNA-4mk3



POKA Patrol
(Count Checker)



CNA-4mk3

Assembly Digital Relay Counter Judgment RoHS

- Torque tightening verification counter
- Max. 4 LS torque wrenches can be connected as one time.
- CNA-4mk3 easily establishes Pokayoke, error-proofing system at Low Cost.

Count Display	16 × 32 dot-matrix LEDs
OK/NG Judgment Display	30 × 25 square display lamp (commonly used for OK/NG) OK: Blue lamp turned on NG: Red lamp blinking + Buzzer sounds (4 patterns)
Work No. Selection Display	1-digit 7-segment LED
Count Input	Contact input × 4
Max. tightening number of bolts	99 counts
Max. number of works	8 sets
OK/NG judgment setting	<ul style="list-style-type: none"> • Preset judgment • END input judgment • Automatic judgment (0 to 300 seconds in steps of 1 second)
Output function	<ul style="list-style-type: none"> • OK/NG output (Relay contact output rating: 30 V DC, 1 A, 125 V AC, 0.3 A) • Torque wrench selection signal output (Open collector rating: 100 mA)
Input function	<ul style="list-style-type: none"> • SELECT input × 4 • START input • END input • RESET input • WORK SENSOR input
Timer function setting	<ul style="list-style-type: none"> • Double count prevention timer (0 to 10 seconds in steps of 0.1 second) • Automatic reset timer (0 to 60 seconds in steps of 1 second) • Interval warning timer (0 to 99 seconds in steps of 1 second)
Setting method	Special-purpose application software (USB communication), key operation
Working temperature range	0 ~ 40 [°C]
Working humidity	Below 85%RH (no condensation)
Electricity Consumption [W]	Below 10
Power supply AC [V]	100 ~ 240V ± 10% 50/60Hz
Weight	Approx. 400g

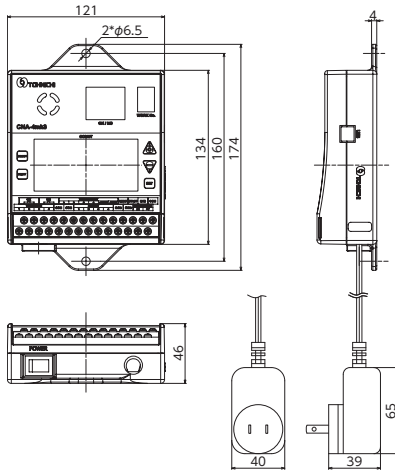

As tightening confirmation method, there is a counter method which is CNA-4mk3. CNA-4mk3 is designed for judging OK/NG as to the tightening number of bolts to prevent them from being left untightened. Capable of building a variety of Pokayoke, Error-Proofing system.

Introduction of major functions of CNA-4mk3

- Work Sensor Input
By connecting a detection sensor to this input, NG judgment can be made if the tightening work has moved from certain position without tightening.
- Start Input
Newly added start input terminal to be able to receive operation start direction from proximity switch etc.
- Interval Warning
Unless next tightening work is completed within a setting time, an alarm sounds to warn the operator.
- Capable of Setting up to 8 Units of Work
No. of tightening bolts for up to 4 torque wrenches can be displayed on one unit.
- Low Cost Error-Proofing System
For all-in-one specifications, easily setup error-proofing system with reasonable price.
- Operation in Order or at random
In case of handling a variety of works with multiple torque wrenches, usage order can be set.

Case Example

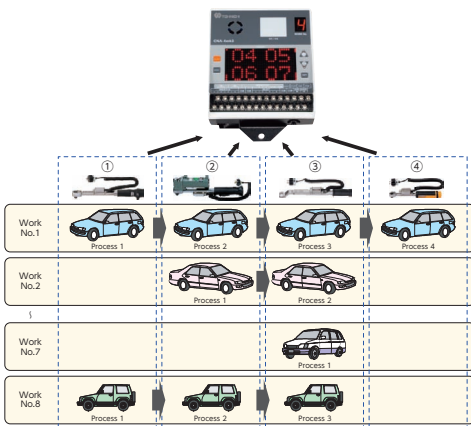



Tightening Data Management System

Wired Data Transfer Torque Wrench
Model: CSPD and QSPD

Wired Data Transfer Semi-Automatic Airtork
Model: ACQSPD

Wired transfer of actual applied torque for complete verification of "click" wrench tightening

Model	Description	Figure	Display
CSPD	Wired Data Transfer Torque Wrench		
ACQSPD	Wired Data Transfer Semi-Automatic Airtork		CD5 Refer to P.66.

Note
1. Interchangeable head is sold separately.
2. CSPD and QSPD models are supplied upon request.

Outline

Wired system features highly reliable transmitter mounted on a click torque wrench that captures actual applied torque data. CD-5 display shows actual tightening torque and judgment is made whether or not the torque is within the programmed hi/lo parameters. Connect to PLC and PC software to store and control data for increased tightening reliability.

System

Wired Data Transfer Torque Wrench
Model: CSPD with QH head

Wired transfer of actual tightening torque

Wired Data Transfer Semi-Automatic Airtork
Model: ACQSPD

Wired transfer of actual tightening torque with operation of provisional tightening

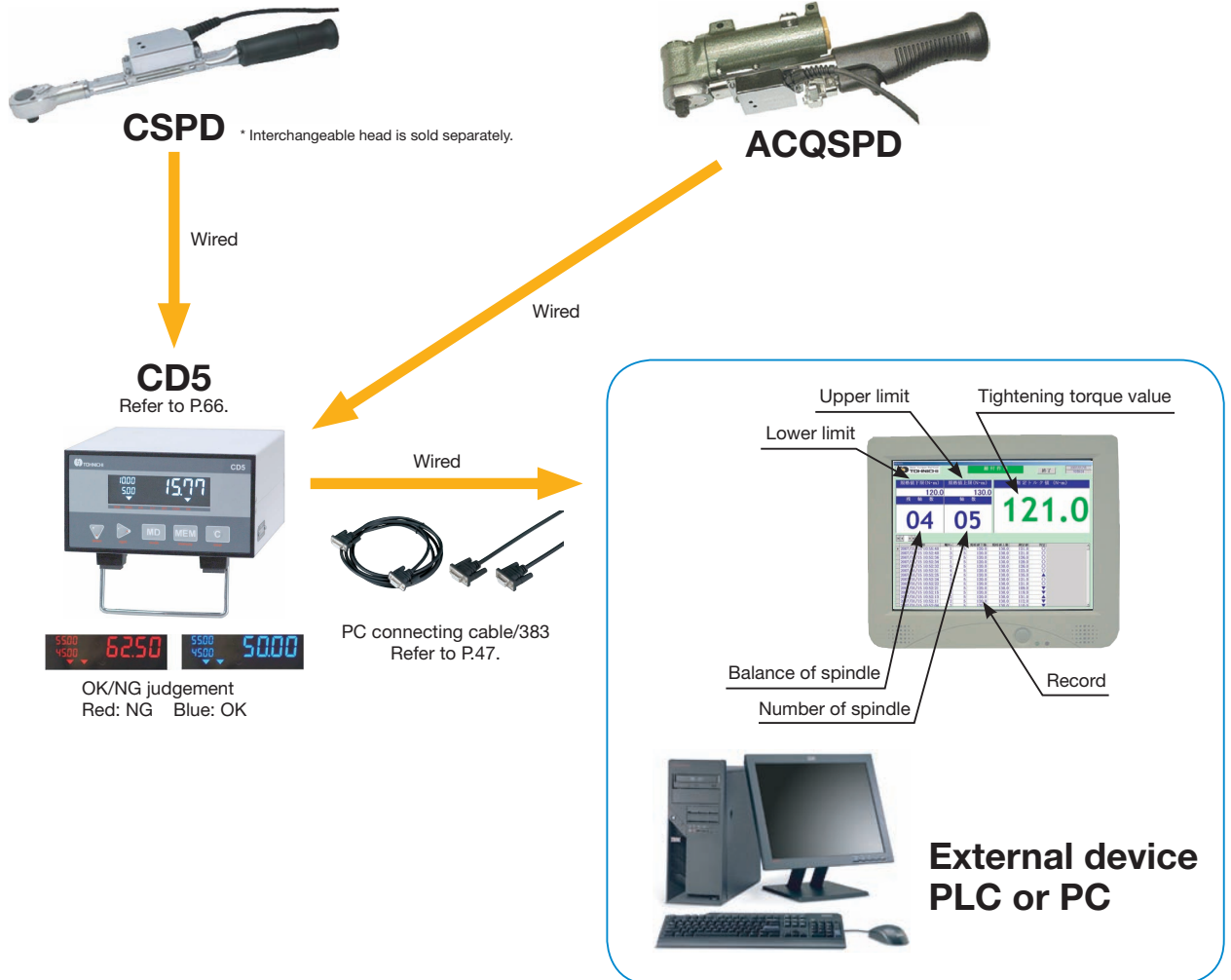





Tightening Data Management System

Wireless Data Transfer Torque Wrench
Model: FHD and FHDS

Wireless Data Transfer Semi-Automatic Airtork
Model: ACQSPFHDS

Wireless transfer of actual applied torque for complete verification of “click” wrench tightening

Model	Description	Figure	Receiver
FHDS	Wireless Data Transfer Torque Wrench (Without torque data display)		
FHD	Wireless Data Transfer Torque Wrench (With torque data display)		
ACQSPFHDS	Wireless Data Transfer Semi-Automatic Airtork		Receiver R-FHD256

Note
1. Interchangeable head is sold separately.
2. FHD and FHDS models are supplied upon request.
3. Refer to page 30 for condition of wireless equipment in each country.

Outline

FHD system features highly reliable FHSS transmitter mounted on a click torque wrench that captures actual applied torque data. R-FHD256 receiver accepts signal and confirms back to wrench with “Answerback” system. Connection to PLC and PC software allows for management of fastener count, serial number, torque ID, and judgment parameters.

System

Wireless Data Transfer Torque Wrench
Model: CSPFHDS with QH head
Simplified small case version with extended battery life

Wireless Data Transfer Torque Wrench
Model: CSPFHD with QH head
LCD transmitter display shows data for convenient user confirmation

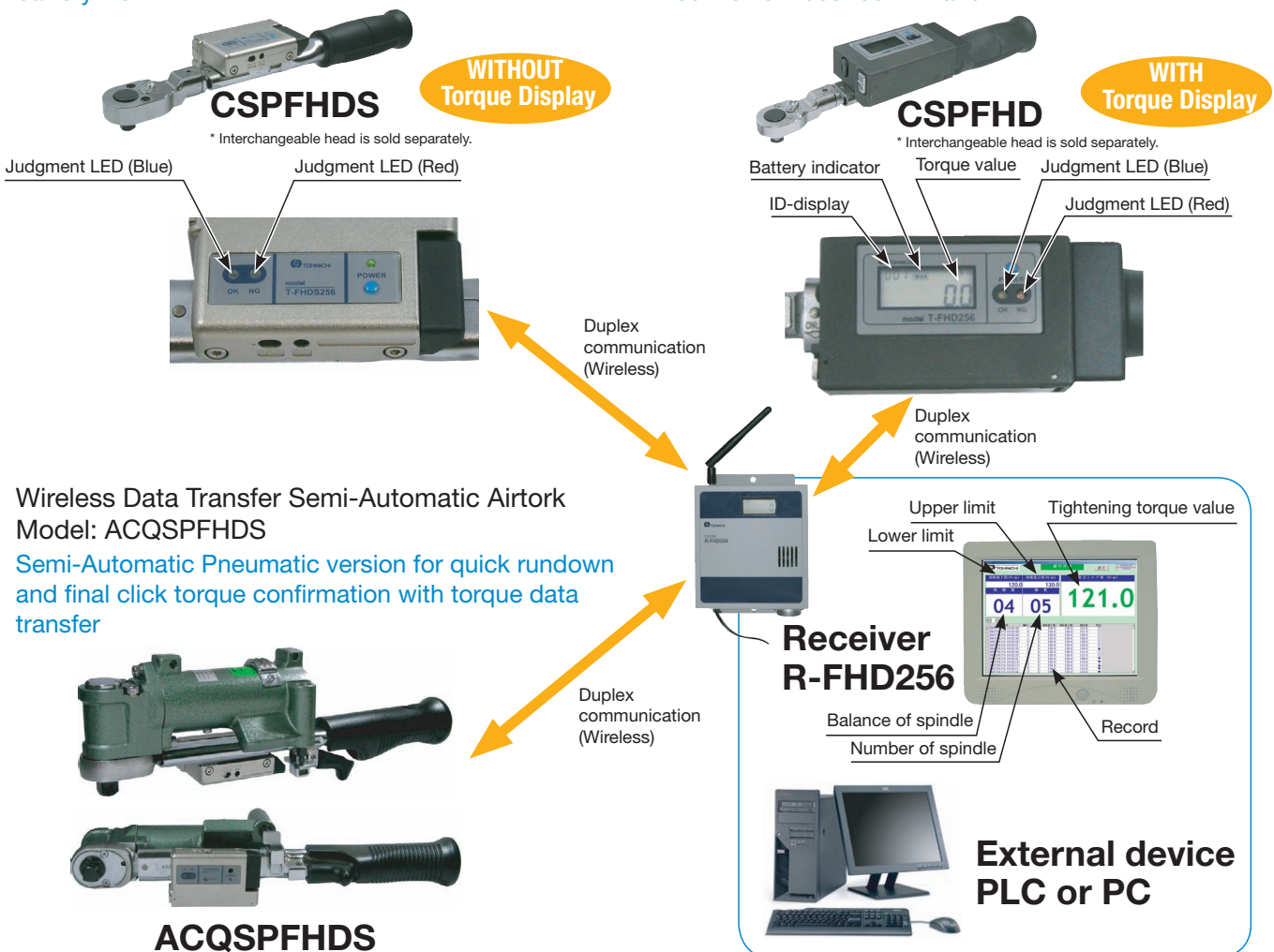

Tightening Data Management System

Wireless Digital Torque Wrench
Model: CEM3-G-BTD/Duplex communication

Ideal for managing tightening data in cell-production or sub-assembly lines

Merit

- Preventing tightening errors such as missed tightening and over torque by setting upper/lower limit on a digital torque wrench
- Traceable for product claims
- Managing actual applied torque value used in the assembly lines
- Reducing potential costs associated the additional checks and reworks

Outline

"CEM3-G-BTD" provides duplex wireless transfer of data between the wrench and PC. "CEM3-G-BTD + Management software" adds additional duplex functionality by sending set torque value, fastener quantity, and judgments to the wrench for various tightening applications. One digital torque wrench can replace several manual preset click torque wrenches with the additional benefit of storing the actual applied torque. Upper/Lower limit can be set on a digital torque wrench from PC with a duplex communication. As a result, reducing operative cost and time becomes possible.

System

Instantly send tightened torque data back to PC



Wireless Digital Torque Wrench
CEM3-G-BTD

Upper/Lower limit can be set wirelessly from PC to torque wrench.



Duplex communication

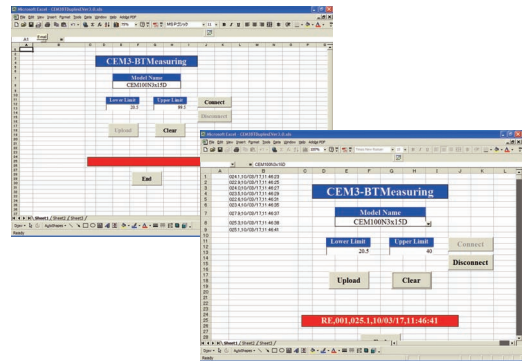
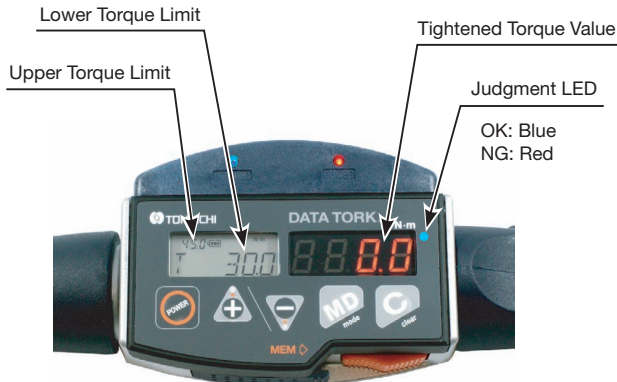

RoHS

Bluetooth Specification	
Communication Method	Bluetooth
Radio Frequency Range	2.4GHz
Communication Distance	Approx. 10m
Continuous Use	Approx. 8 hours

Handy Terminal HT-S5



Compact data collection device for CEM3-G-BT

- Upload & download torque measuring information
- Guides user through torque assembly & quality inspection processes
- Statistics and charting capabilities

Tohnichi Head Size	Model		Torque Range [N·m]		Overall Length [mm]	Weight [kg]
	Simplex Communication	Duplex communication	Min.-Max.	1 digit		
8D	CEM10N3×8D-G-BTS	CEM10N3×8D-G-BTD	2-10	0.01	212	0.54
10D	CEM20N3×10D-G-BTS	CEM20N3×10D-G-BTD	4-20	0.02	214	0.55
12D	CEM50N3×12D-G-BTS	CEM50N3×12D-G-BTD	10-50	0.05	282	0.66
15D	CEM100N3×15D-G-BTS	CEM100N3×15D-G-BTD	20-100	0.1	384	0.71
19D	CEM200N3×19D-G-BTS	CEM200N3×19D-G-BTD	40-200	0.2	475	0.86
22D	CEM360N3×22D-G-BTS	CEM360N3×22D-G-BTD	72-360	0.4	713	1.21
22D	CEM500N3×22D-G-BTS	CEM500N3×22D-G-BTD	100-500	0.5	949	4.08
32D	CEM850N3×32D-G-BTS	CEM850N3×32D-G-BTD	170-850	1	1387	5.22

Accuracy ±1%

Note

1. Overall length does not include interchangeable head.
2. Refer to pages 42-45 for details with interchangeable heads.
3. PH (Pipe wrench head) is not applicable due to difference of effective length.
4. Bluetooth adapter (optional) is necessary if your PC is not compatible.
5. Consult Tohnichi for management software (optional) for data setting and processing.
6. CEM3-G-BT models have two types.
Simplex communication (BTS): CEM3-G-BT → Transfer measurement data to PC
Duplex communication (BTD): Set torque and upper/lower limits in PC → CEM3-G-BT → Transfer measurement data to PC
7. Standard CEM3-G is unable to be modified into CEM3-G-BT.
8. Refer to page 30 for condition of wireless equipment in each country.

Standard Accessories Battery pack/BP-5, Quick charger/BC-3-G, QH interchangeable head (P.44)

Tightening Data Management System

Wireless Digital Torque Wrench
 Models: HT-S5 & CEM3-G-BTS/Simplex communication
 Software: TDMS

Ideal for tightening torque inspection.

The inspection data management becomes economically and easily possible with Excel®.

Merit

- Reduced overtime due to early detection such as overtorque and loosening torque.
- Monitored data can be used for proof in protection against product liability.
- The degree of wear and the tendency of the tools can be predicted.
- Preventing defects in a large quantity of products.

Outline

"CEM3-G-BTS" provides wireless transfer of data from the wrench to PC as it is being applied or collected. All data can be managed in a master data file consisting of Excel® and torque data can be easily monitored and stored. In order to maintain high quality, it is important to establish standard values, and then track and manage with statistical processing. Tightening work can be conducted with portion master file which can be controlled by Excel®. [N], [X-bar], [σ], [cp], and [cpk] are automatically calculated and stored in an Excel® file.

System

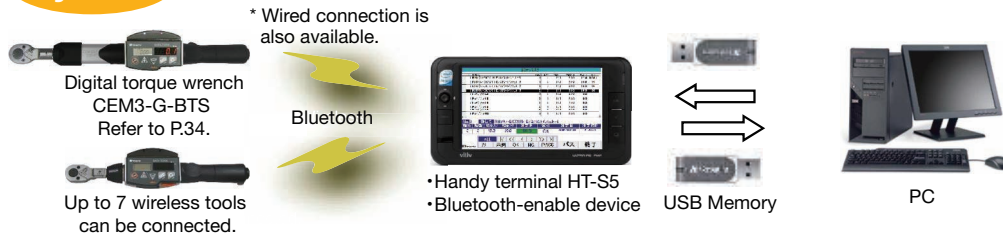

[Output Excel® Data Example]

- A data of [N], [X-bar], [σ], [cp], and [cpk] is monitored in Excel® file.

Portion Name	Number of Spindle	TI Low	TI High	N	Max	Min	R	Xbar	Sigma (n-1)	Sigma (n)	Cp	Cpk
RH Mount BKTXLH E/G Mount Insulator	1	15.0	20.0	4	19.4	16.5	2.9	17.7	1.22474487	1.06066017	0.68041382	0.62598071
RH Mount BKTXRH E/G Mount Insulator	1	10.0	15.0	4	21.6	13.6	8	17.55	3.38772293	2.93385412	0.24598627	-0.250906
Fr Hubnuts LH	2	12.0	17.0	8	21.0	13.5	7.5	18.1	2.21891883	2.07364414	0.37591405	0.13532906
Fr Hubnuts RH	2	12.0	17.0	5	18.5	14.1	2.4	15.48	0.91760558	0.82073138	0.90816071	0.216171

- More detailed information available.

Item Name	Sample Master							
Portion Name	Fr Hubnuts LH							
Number of Spindle	2							
Spindle No.	ALL							
TI Low	12.0							
TI High	17.0							
N	Max	Min	R	Xbar	Sigma (n-1)	Sigma (n)	Cp	Cpk
8	21.0	13.5	7.5	18.1	2.218918828	2.073644135	0.375914045	0.135329056
Spindle No.	Measured Torque	Judge	Date	Time				
1	15.6	OK	16/Oct/2012	17:23:20				
1	21.0	NG(H)	16/Oct/2012	17:37:02				
1	15.7	OK	16/Oct/2012	17:37:43				
1	13.5	OK	16/Oct/2012	17:38:11				
2	14.7	OK	16/Oct/2012	17:30:22				
2	15.2	OK	16/Oct/2012	17:37:06				
2	16.4	OK	16/Oct/2012	17:37:45				
2	16.7	OK	16/Oct/2012	17:38:13				

Note
 [Excel®] is a trademark registration of Microsoft Co., Ltd.
 [Bluetooth] is a trademark registration of Bluetooth SIG, Inc.

Model	Description	Language
TDMS	Software only	Japanese
TDMS-E		English
TDMS-C		Chinese
TDMSHT	Software + Handy Terminal/HT-S5	Japanese
TDMSHT-E		English
TDMSHT-C		Chinese

- Note
1. Software installation is allowed on a single PC at one time.
 2. Applicable digital torque wrench is CEM3-G-BTS. Refer to page 34.

System Requirements	
Operation System	Microsoft Windows XP (SP3)
	Microsoft Windows Vista 32bit (SP1)
	Microsoft Windows 7 32bit version
Recommended Hardware	CPU speed 300MHz
	CPU Intel Pentium/Celeron, AMD K6/Athron/Duron
	RAM 126MB
	Hard Disk Capacity 2.1GB
	Display Super VGA 800 × 600
	Drive CD-ROM or DVD drive
	Communication Bluetooth® (2.0+EDR) SSP profile compliant or SSP profile compliant module
USB USB2.0 × 1	

CEM3-G

DATA TORQ
(Digital Torque Wrench)

Direction



CEM100N3×15D-G



Inspection

Digital

Interchangeable

Direct Reading

Re-Chargeable

RoHS

- Dual LED & LCD displays for optimal viewing
- 999 memory storage capacity
- For inspection and tightening



CEM20N3×10D-G



CEM850N3×32D-G

Common Specifications

Display	7 segments LED 4 lines 10mm (Torque value) 14 segments LCD 3 lines 7mm (Counter) 7 segments LCD 4 lines 3mm (Clock) Battery life indicator (4 steps) Judgment LED RED/BLUE
Number of Data Memory	999 (M-2 mode: 99 data)
Communication Functions	RS232C (2400-19200bps) Serial output corresponding to a USB connector
Power Supply	Ni-MH rechargeable battery
Continuous Use	Approx. 20 hrs with fully charged (8 hours by 1 hour recharging)
Recharging Time	Approx. 3.5 hours
Operation Temperature	0-40 Celsius no condensation
Basic Functions	Peak Hold, Auto memory & resetting, Tightening completion buzzer, Judgment of measured data, Auto zero setting, Auto off (3 minutes), Clock

Model	Torque Range										Hand Force [N]	Overall Length [mm]	Weight [kg]
	N-m		kgf-cm		kgf-m		lbf-in		lbf-ft				
	Min.-Max.	1digit	Min.-Max.	1digit	Min.-Max.	1digit	Min.-Max.	1digit	Min.-Max.	1digit			
CEM10N3×8D-G	2-10	0.01	20-100	0.1	0.200-1.000	0.001	20.0-90.0	0.1	1.50-7.30	0.01	48.1	212	0.46
CEM20N3×10D-G	4-20	0.02	40-200	0.2	0.400-2.000	0.002	36.0-180.0	0.2	3.00-14.50	0.02	92.2	214	0.47
CEM50N3×12D-G	10-50	0.05	100-500	0.5	1.000-5.000	0.005	100.0-440.0	0.5	7.50-36.00	0.05	196.9	282	0.58
CEM100N3×15D-G	20-100	0.1	200-1000	1	2.00-10.00	0.01	200-880	1	15.0-73.0	0.1	275.5	384	0.63
CEM200N3×19D-G	40-200	0.2	400-2000	2	4.00-20.00	0.02	360-1700	2	30.0-150.0	0.2	428.3	475	0.78
CEM360N3×22D-G	72-360	0.4	720-3600	4	7.2-36.00	0.04	650-3100	4	52.0-260.0	0.4	498.6	713	1.13
CEM500N3×22D-G	100-500	0.5	1000-5000	5	10.00-50.00	0.05	890-4400	5	73.0-360.0	0.5	549.5	949	4.00
CEM850N3×32D-G	170-850	1	-	-	17.0-85.0	0.1	-	-	124-620	1	608	1387	5.14

Accuracy ±1%

Note

1. Overall length does not include interchangeable head.
2. For interchangeable head, refer to page 42-45.
3. For infrared data transfer, use with R-DT999 (Refer to page 66).
4. PH (Pipe wrench head) type interchangeable head is not available for this model.
5. CEM500N3×22D-G and CEM850N3×32D-G have knurled handles.
6. For USB data transfer, use with No. 584 connecting cable (Optional). Refer to page 47.

Standard Accessories

1. Battery pack/BP-5
2. QH interchangeable head. Refer to page 44.
3. Quick battery charger/BC-3-G (100-240V).

CEM3-P

RoHS

- Programmable version of CEM3-G with data management software that links work name with test results.

Torque Accuracy	±1%
Portion Registration Memory	Max. 100 parts (Part name, number of screws, tightening direction, high/low torque, measuring order)
Measurement Data Storage	Up to 3,000 screw data (vary depending on parts registered), measurement part name, measured value, pass/fail judgment, measurement time and date)



CEM50N3×12D-P



Display part
Left: Part name, Right: Torque value

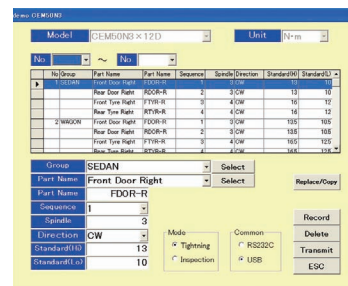

CEM3-P application software

Model	Model	Model
CEM10N3×8D-P	CEM100N3×15D-P	CEM500N3×22D-P
CEM20N3×10D-P	CEM200N3×19D-P	CEM850N3×32D-P
CEM50N3×12D-P	CEM360N3×22D-P	

Handy Terminal

HT-S5



Compact data collection device for CEM3-G

- Upload & download torque measuring information
- Guides user through torque assembly & quality inspection processes
- Statistics and charting capabilities

Battery Pack (P.47)

Model
BP-5

Quick Battery Charger (P.47)

Model	Description
BC-3-G	100V-240V

Printer (P.67)

Model
EPP16M3

Connecting Cable (P.47)

Part #	Applicable Models
575	CEM3-G, CEM3-P, R-DT999 → PC, EPP16M3
584	CEM3-G, CEM3-P, R-DT999G → PC

Data Filing System (P.66)

Model	Media
DFS	CD-ROM

CTB2-G Digital Retightening Torque Wrench

Inspection

Digital

Interchangeable

Signal

Re-Chargeable

RoHS

Direction



CTB100N2×15D-G



CTB850N2×32D-G

- Detects movement of fastener for more accurate testing
- Software converts measured torque to initial tightening torque value.

Accuracy ±1%

Model	Torque Range										Hand Force [N]	Overall Length [mm]	Weight [kg]
	N-m		kgf-cm		kgf-m		lbf-in		lbf-ft				
	Min.-Max.	1digit	Min.-Max.	1digit	Min.-Max.	1digit	Min.-Max.	1digit	Min.-Max.	1digit			
CTB10N2×8D-G	2-10	0.01	20-100	0.1	0.2-1	0.001	20-90	0.1	1.5-7.3	0.01	48.1	212	0.46
CTB20N2×10D-G	4-20	0.02	40-200	0.2	0.4-2	0.002	36-180	0.2	3-14.5	0.02	92.2	214	0.47
CTB50N2×12D-G	10-50	0.05	100-500	0.5	1-5	0.005	100-440	0.5	7.5-36	0.05	196.9	282	0.58
CTB100N2×15D-G	20-100	0.1	200-1000	1	2-10	0.01	200-880	1	15-73	0.1	275.5	384	0.63
CTB200N2×19D-G	40-200	0.2	400-2000	2	4-20	0.02	360-1700	2	30-150	0.2	428.3	475	0.78
CTB360N2×22D-G	72-360	0.4	720-3600	4	7.2-36	0.04	650-3100	4	52-260	0.4	498.6	713	1.13
CTB500N2×22D-G	100-500	0.5	1000-5000	5	10-50	0.05	890-4400	5	73-360	0.5	549.5	949	4.00
CTB850N2×32D-G	170-850	1	-	-	17-85	0.1	-	-	124-620	1	608	1387	5.14

- Note**
1. Overall length does not include interchangeable head.
 2. For interchangeable head, refer to page 42-45.
 3. For infrared data transfer, use with R-DT999 (Refer to page 66).
 4. PH (Pipe wrench head) type interchangeable head is not available for this model.

- Standard Accessories**
1. Battery pack/BP-5
 2. QH interchangeable head (P.44).
 3. Quick battery charger/BC-3-G (100V-240V).

Common Specifications

Data Memory	999 data (T-point torque)
Arithmetic Function	Sampling, Maximum, Minimum, Means
Measurement Mode	Peak/Run
Data Output	RS232C I/F, USB serial output
Zero Adjustment	Auto zero function (C key)
Other Function	Auto power off (3 min./10 min./30 min./non)
Power Source	Ni-MH Nickel metal-hydride battery
Continuous Use	Approx. 20 hours (8 hours by 1 hour charging)
Battery Charge	Approx. 3.5 hours
Operating Condition	0-40 Celsius

Battery Pack (P.47)

Model
BP-5

Printer (P.67)

Model
EPP16M3

Quick Battery Charger (P.47)

Model	Description
BC-3-G	100-240V

Connecting Cable (P.47)

Part #	Applicable Models
575	CTB2-G → PC, EPP16M3
584	CTB2-G, R-DT999G → PC

Data Filing System (P.66)

Model	Media
DFS	CD-ROM

Advantages of the New Retightening Method: T-point Method

- Anyone can measure the tightening torque easily.
- Requires less time to perform the measurement.
- Dispersion of data is small (Figure-3).
- No individual interpretation or performance variable is involved in measuring the torque (Figure-3).
- Internal software converts measured torque to initial tightening torque value (Figure-3).

Figure-1 Traditional retightening torque method

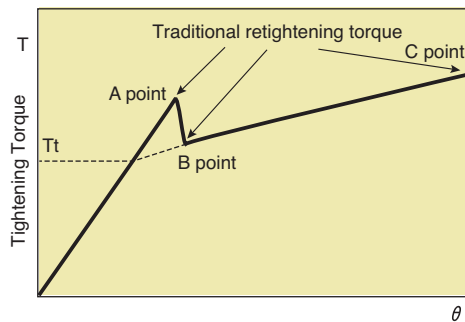

Retightening Torque Method

Retightening torque method aims to measure the torque at which a tightened bolt start to rotate again as further torque is applied. The retightening measured values are classified as one of these three kinds:

- The torque which overcome the static friction of the bolt (A point).
- The torque at which the bolt starts on turn continuously (B point).
- The maximum torque at this inspection (C point).

Proposal of T-point method (Figure-2)

Retightening torque first starts with the rotation of the head only, then the screw starts to rotate. Shifting from static friction to dynamic friction, the friction whip settles and the torque starts to increase at the steady pace again. T-point method figures TT as retightening torque value.

Figure-2 New retightening torque method by CTB2-G

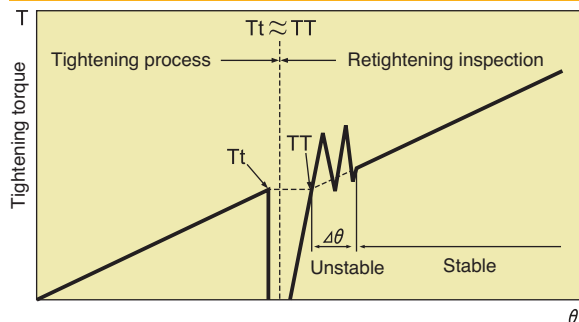
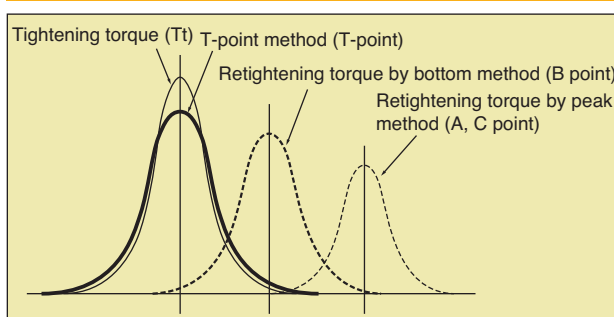

Figure-3 Distribution of retightening torque



Refer to Tohnichi Torque Handbook Vol. 8 on page 42 to 43 for the details.

DB/DBE/DBR

Inspection

Dial Indicating

Direct Reading

RoHS

Direction Dial Indicating Torque Wrench



DB12N4



DB100N



DBE700N



Memory Pointer (Red needle)

DB Optional Accessories



846

Carrying Case (P.46)

Part #	Applicable Model Dimension [mm]	Weight [kg]
846	DB100N-S, CDB100N×15D-S or less (H170 × W500 × D100)	1.0
847	DB280N-S, CDB280N×22D-S or less (H170 × W740 × D100)	1.6

- Memory pointer for easy torque reading
- Ideal for torque measuring and quality check applications

Accuracy ±3%

S.I. Model	Torque Range [N-m/kN-m]		Metric Model	Torque Range [kgf-cm/kgf-m]		American Model	Torque Range [lbf-in/lbf-ft]		Overall Length [mm]	Square Drive [mm]	Weight [kg]	
	Min.-Max.	Grad.		Min.-Max.	Grad.		Min.-Max.	Grad.				
DB1.5N4-S	0.2-1.5	0.02	15DB4-S	2-15	0.2	DB13I-2AS	0-13	0.2				
DB3N4-S	0.3-3	0.05	30DB4-S	3-30	0.5	DB26I-2AS	0-26					
DB6N4-S	0.6-6	0.1	60DB4-S	6-60	1	DB40I-2AS	0-40		205	6.35	0.4	
DB12N4-S	1-12	0.2	120DB4-S	10-120	2	DB75I-2AS	0-75	1				
DB25N-1/4-S			230DB3-1/4-S			DB150I-2AS						
DB25N-S	3-25		230DB3-S	30-250	5	DB150I-3AS	0-150	2	245		0.6	
DB50N-S	5-50		450DB3-S	50-500		DB300I-3AS	0-300	5	320		9.5	
DB100N-3/8-S			900DB3-3/8-S			DB600I-3AS						
DB100N-S	10-100	1	900DB3-S	100-1000	10	DB600I-4AS	0-600	10	400		0.7	
							lbf-ft	lbf-ft				
						DB25F-3AS	0-25		320		0.6	
						DB50F-3AS		0.5			9.5	
						DB50F-4AS	0-50		400		0.7	
DB200N-S	20-200	2	1800DB3-S	200-2000	20	DB100F-4AS	0-100	1	500			
				kgf-m	kgf-m						12.7	1.0
						DB175F-4AS	0-175	2	540			
DB280N-1/2-S			2800DB3-1/2-S									
	30-280			3-28					690		1.65	
DB280N-S			2800DB3-S			DB250F-6AS	0-250					
		5			0.5			5				
DB420N-S	40-420		4200DB2-S	4-42		DB350F-6AS	0-350		890		2.5	
DBE560N-S	50-560		5600DBE2-S	5-56					1100		4.0	
DBE700N-S	70-700		7000DBE2-S	7-70		DB500F-6AS	0-500	10	1260		5.5	
DBE850N-S	100-850	10	8500DBE2-S	10-85	1				1360		6.1	
DBE1000N-S	100-1000		10000DBE2-S	10-100		DB800F-8AS	0-800		1490		6.4	
								10			25.4	
DBE1400N-S	200-1400		14000DBE2-S	20-140		DB1000F-8AS	0-1000		1740		8.6	
		20			2							
DBE2100N-S	200-2100		21000DBE2-S	20-210		DB1500F-8AS	0-1500		2140		12.8	
								20				
DBE2800N-S	300-2800	50	28000DBE2-S	30-280		DB2000F-12AS	0-2000		2380		16.8	
											38.1	
DBR4500N-S	0.5-4.5	0.05	45000DBR-S	50-450	5	DB3000F-12AS	0-3000	50	1285		26.5	
DBR6000N-S	0.6-6	0.1	60000DBR-S	60-600					1585	44.5	27.5	

Note

1. "Without memory pointer" models are available. Remove "-S" from the model name when ordering. (Ex. DB100N)
2. DBR models require winch or mechanical loading device.
3. DBR Models are supplied upon request.
4. For models having over 25.4mm square drive, use with a through-hole socket.
5. Accuracy of American models is warranted from 20% of max. torque.

CDB-S

Interchangeable Head Type Dial Indicating Torque Wrench

Direction



CDB14N4x8D-S



CDB100Nx15D-S

Inspection Dial Indicating Interchangeable Direct Reading Memory Pointer RoHS

- Interchangeable head version of DB
- Ideal for torque measuring and quality inspections

Accuracy ±3%

Tohnichi Head Size	S.I. Model	Torque Range [N·m]		Metric Model	Torque Range [kgf·cm/kgf·m]		American Model	Torque Range [lbf·in/lbf·ft]		Overall Length [mm]	Weight [kg]
		Min.-Max.	Grad.		Min.-Max.	Grad.		Min.-Max.	Grad.		
8D	CDB7N4x8D-S	0.7-7	0.1	70CDB4-S	7-70	1	70CDB4-A-S	6-60	1	215	0.45
	CDB14N4x8D-S	2-14	0.2	140CDB4-S	20-140	2	140CDB4-A-S	20-120	2		
10D	CDB25Nx10D-S	3-25	0.5	250CDB-S	30-250	5	250CDB-A-S	30-220	5	255	0.48
12D	CDB50Nx12D-S	5-50		500CDB-S	50-500		500CDB-A-S	40-430		330	
15D	CDB100Nx15D-S	10-100	1	1000CDB-S	100-1000	10	1000CDB-A-S	7-70	1	415	0.76
19D	CDB200Nx19D-S	20-200	2	2000CDB-S	200-2000	20	2000CDB-A-S	14-140	2	525	1.0
22D	CDB300Nx22D-S	30-300	5	3000CDB-S	3-30	0.5	3000CDB-A-S	20-220	5	720	1.65
	CDB420Nx22D-S	40-420		4200CDB-S	4-42		4200CDB-A-S	30-300		920	

- Note
1. Overall length does not include interchangeable head.
 2. PH (Pipe wrench head) type interchangeable head is not available for this model.
 3. Interchangeable heads are optional.

SCDB-S

European Style Interchangeable Head Type Dial Indicating Torque Wrench

Direction



SCDB50N-S

Inspection Dial Indicating Interchangeable Direct Reading Memory Pointer RoHS

- Specialized version of DB
- Accepts DIN interchangeable head connection

Accuracy ±3%

S.I. Model	Torque Range [N·m]		Head Size [mm]	Overall Length [mm]	Weight [kg]
	Min.-Max.	Grad.			
SCDB25N-9x12-S	3-25	0.5	9x12	271	0.48
SCDB50N-9x12-S	5-50		9x12	342	0.53
SCDB100N-9x12-S	10-100	1	9x12	422	0.76
SCDB200N-14x18-S	20-200	2	14x18	535	1

- Note
1. Overall length does not include interchangeable head.
 2. Applicable to European style head. Tohnichi's interchangeable heads are not available for this model.

T-S

T-Handle Dial Indicating Torque Wrench

Direction



T90N-S

Inspection Dial Indicating Direct Reading Memory Pointer RoHS

- Dual handle for increased stability
- Memory pointer for easy reading

Accuracy ±3%

S.I. Model	Torque Range [N·m]		Metric Model	Torque Range [kgf·cm/kgf·m]		American Model	Torque Range [lbf·in/lbf·ft]		Overall Length [mm]	Neck Length [mm]	Square Drive [mm]	Weight [kg]
	Min.-Max.	Grad.		Min.-Max.	Grad.		Min.-Max.	Grad.				
T23N-S	3-23	0.5	230T-S	30-230	5	T200I-3AS	20-200	2	205	71	9.5	0.41
T45N-S	5-45		450T-S	50-450		T400I-3AS	50-400	5	261	82		0.53
T90N-S	10-90	1	900T-S	100-900	10	T65F-4AS	10-65	1	376	102.5	12.7	0.8
T180N-S	20-180	2	1800T-S	200-1800	20	T130F-4AS	20-130	2	656	118.5		1.2
T700N-S	70-700	10	7000T-S	7-70	1	7000T-A-S	50-500	5	1300	19.0	4	
T1000N-S	100-1000		10000T-S	10-100		10000T-A-S	50-700		1630		4.8	
T1400N-S	200-1400	20	14000T-S	20-140	2	14000T-A-S	100-1000	10	1880	25.4	6.2	
T2100N-S	200-2100		21000T-S	20-210		21000T-A-S	200-1500	2500	10			
T2800N-S	300-2800	50	28000T-S	30-280	5	28000T-A-S	200-2000	20	2960	38.1	15.5	
T4200N-S	400-4200		42000T-S	40-420		42000T-A-S	400-3000	3660	21.5			

- Note
1. T700N-S to T4200N-S models are supplied upon request.
 2. For models having over 25.4mm square drive, use with a through-hole socket.

Torque Wrench for Quality Inspection



Interchangeable Socket

RoHS

SOCKET FOR HAND TOOL

From Bolt	Inlet Drive (Female)	From Torque Tool			
	Width Across Flats (B)	6.35	9.5	12.7	19.0
	8	201			
	10	202	210		
	12	203	211		
	13	204	212		
	14		213	220	
	16		216	227	
	17		214	221	
	18		217	228	
	19		215	222	
	21			229	237
	22			223	230
	24			224	231
	27			225	232
	30			226	233
	32				234
	34				236
	36				235
	41				
	46				
	50				
	55				



SOCKET

SOCKET FOR HAND TOOL

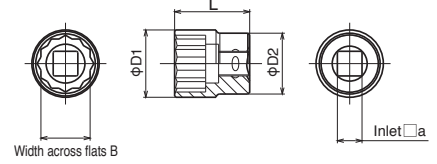

Width across flats B

How to Order (Hand Tools) SOCKET

Indicate model name and Part #

[Ex.] SOCKET **2H-10** **202**
 Socket Inlet sign | Part #
 Purpose sign | Width across flats

ADAPTER

Indicate model name and Part #

[Ex.] ADAPTER **2H-3** **270**
 Inlet Sign (Female) | Part #
 Purpose sign | Inlet sign (Male)

ADAPTER FOR HAND TOOL

To Socket	From Torque Tool				
	Inlet Drive (Female)	6.35	9.5	12.7	19.0
	Square Size (Male)	2H	3H	4H	6H
	6.35 (2)		271		
	9.5 (3)	270		273	
	12.7 (4)	277	272		275
	19 (6)			274	
	25.4 (8)				276



ADAPTER

ADAPTER FOR HAND TOOL

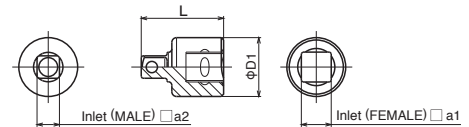

SOCKET FOR PNEUMATIC TOOL

From Bolt	From Torque Tool			
	Inlet Drive (Female)	9.5	12.7	25.4
	Width Across Flats (B)	3P	4P	8P
	10	250		
	12	251		
	13	252		
	14	253	260	
	16	255	264	
	17	254	261	
	18		265	
	19		262	
	21		266	
	22		263	
	32			303
	34			304
	36			305
	41			306
	46			307
	50			308
	55			309



SOCKET

SOCKET FOR PNEUMATIC TOOL

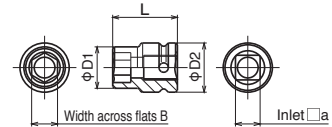

How to Order (Air Tools) SOCKET

Indicate model name and Part #

[Ex.] SOCKET **3P-10** **250**
 Socket Inlet sign | Part #
 Purpose sign | Width across flats

ADAPTER

Indicate model name and Part #

[Ex.] ADAPTER **3P-4** **290**
 Inlet Sign (Female) | Part #
 Purpose sign | Inlet sign (Male)

Note O-ring and pin are included.

ADAPTER FOR PNEUMATIC TOOL

From Bolt	From Torque Tool				
	Inlet Drive (Female)	9.5	12.7	19.0	25.4
	Square Drive (Male)	3P	4P	6P	8P
	9.5 (3)		291		
	12.7 (4)	290		293	
	19 (6)		292		295
	25.4 (8)			294	

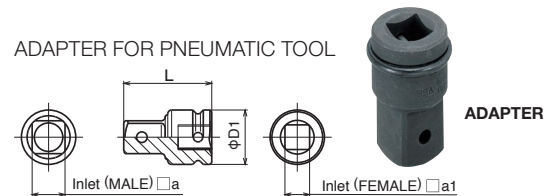

ADAPTER

SOCKET FOR POWER AND HAND TOOL

From Bolt	From Torque Tool				
	Inlet Drive (Female)	6.35	9.5	12.7	19.0
	Width Across Flats (B)	2C	3C	4C	6C
	2.5	430			
	3	431	440		
	4	432	441		
	5		442		
	6		443	450	
	8			451	
	10			452	
	12			453	
	14			454	460
	17				461
	19				462

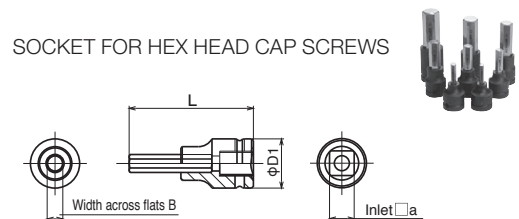

Note 1. O-ring and pin are included.
 2. 430, 431, 432 are not through hole type.

The Relationship between Interchangeable Heads and Torque Wrenches

Tohnichi's interchangeable head wrenches have specific diameter round ends that fit into corresponding head base openings. Head and wrench model names include the diameter sizes so heads can be matched to wrenches that will accept those heads.

For example: SH15D×17 will fit on CL100N×15D

A variety of different head types (SH, RH, QH, RQH, FH, DH, AH and SP-N) can be used on one wrench or different types of wrenches such as CL (for tightening) and CEM3 (for inspection) can use the same head that has the corresponding diameter size.

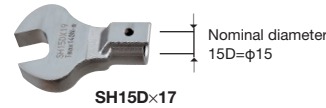

RH

Ring Head

RoHS

The RH type ring heads guarantee the safe work as the axes of bolt and RH ring head are always aligned and prevent the heads will drop.

Note: RH8D×5.5 to RH8D×7 are hex shape.

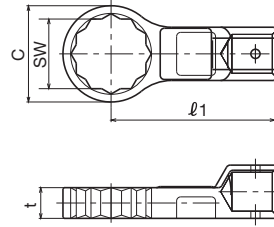

RH15D×17

Tohnichi Head Size	Model (Body Size × Width)	Allowable Torque		Outside Width C [mm]	Thickness t [mm]
		[N·m]	[kgf·cm]		
8D	RH8D×5.5	1.5	15	10.5	5
	RH8D×6	2.4	24	11	
	RH8D×7	3.6	36	12	
	RH8D×8	7.2	72	13.5	6
	RH8D×10	12.2	122	15.5	
	RH8D×11			17	
	RH8D×12	15	140	18	7
	RH8D×13			19	
10D	RH10D×8	7.2	72	12.5	6
	RH10D×10	12.2	122	15.5	7
	RH10D×11	20	200	17	
	RH10D×12			18	
	RH10D×13			19	
	RH10D×14			20	
	RH10D×16			22	
	RH10D×17	25	250	24	8
	RH10D×18			25	
	RH10D×19			26	
12D	RH12D×8	7.2	72	15	5
	RH12D×10	12.2	122	16	
	RH12D×11	20	200	18	5.5
	RH12D×12			20	
	RH12D×13	29.5	295	21	6.5
	RH12D×14	59	590	20	10
	RH12D×16			24	
	RH12D×17			25	
	RH12D×18			26	12
	RH12D×19	70	700	26	
15D	RH15D×12			19	7
	RH15D×13	29.5	295	19	
	RH15D×14			22	
	RH15D×16	59	590	25	8
	RH15D×17			26	
	RH15D×18	100	1000	26	10
	RH15D×19			28	
	RH15D×21			31	
	RH15D×22	140	1400	34	13
	RH15D×24			37	
RH15D×30			41		

Tohnichi Head Size	Model (Body Size × Width)	Allowable Torque		Outside Width C [mm]	Thickness t [mm]
		[N·m]	[kgf·cm]		
19D	RH19D×14	59	590	22.5	8
	RH19D×17			27	10
	RH19D×18	100	1000	28	11
	RH19D×19			29	
	RH19D×21	166	1660	32	13
	RH19D×22			35	
	RH19D×24			39	
	RH19D×27			41	
	RH19D×30	200	2000	44	15
	RH19D×32			47	
22D	RH22D×19	166	1660	30	14
	RH22D×22	255	2550	34	
	RH22D×24			37	15
	RH22D×27	490	4900	41	
	RH22D×30			44	
	RH22D×32			45	
	RH22D×34	500	5000	49	17
	RH22D×36			51	
	RH22D×41			57	
	RH22D×46			62	
27D	RH27D×22	255	2550	38	14
	RH27D×24	350	3500	38	15
	RH27D×27	490	4900	42	16
	RH27D×30	670	6700	46	19
	RH27D×32	750	7500	48	
	RH27D×34	670	6700	51	20
	RH27D×36			52	21
	RH27D×41			58	22
	RH27D×46	750	7500	64	24
	RH27D×50			69	26
32D	RH32D×27	490	4900	43	16
	RH32D×30	670	6700	46.5	
	RH32D×32	860	8600	49	18
	RH32D×34			52	
	RH32D×36			53	
	RH32D×41			59	24
	RH32D×46			65	
	RH32D×50	1200	12000	69	27
	RH32D×55			75	
	RH32D×60			80	29

Inch Size Models

Commonly used in the airline industry and for specific American product installation and maintenance.

Tohnichi Head Size	Model (Body Size × Inner Width [in])	Inner Width [mm]	Allowable Torque		Outside Width C [mm]	Thickness t [mm]
			N·m [lbf·in]	N·m [lbf·in]		
8D	NEW RH8D×1/4	6.35	3.6 [31]	11 [0.43]	5 [0.20]	
	NEW RH8D×5/16	7.94	7.2 [63]	13.5 [0.53]	6 [0.24]	
	NEW RH8D×3/8	9.53	12.2 [108]	15 [0.59]		
	NEW RH8D×7/16	11.11	15 [132]	17 [0.67]	7 [0.28]	
	RH10D×1/4	6.35		11 [0.43]		
10D	RH10D×5/16	7.94	7.2 [64]	12.5 [0.49]	6 [0.24]	
	RH10D×3/8	9.53	12.2 [108]	15.5 [0.61]	7 [0.28]	
	RH10D×7/16	11.11		17 [0.67]		
	RH10D×1/2	12.7	25 [221]	19 [0.75]	8 [0.31]	
	RH10D×9/16	14.29		20 [0.79]		
	RH12D×3/8	9.53	12.2 [108]	16 [0.63]	5 [0.20]	
12D	RH12D×7/16	11.11	20 [177]	18 [0.71]	5.5 [0.22]	
	RH12D×1/2	12.7	29.5 [261]	21 [0.83]	6.5 [0.26]	
	RH12D×9/16	14.29		20 [0.79]		
	RH12D×5/8	15.88	59 [522]	24 [0.94]	10 [0.39]	

Tohnichi Head Size	Model (Body Size × Inner Width [in])	Inner Width [mm]	Allowable Torque N·m [lbf·in]	Outside Width C [mm]	Thickness t [mm]
RH15D×9/16	14.29		22 [0.87]		
RH15D×5/8	15.88	59 [522]	25 [0.98]	8 [0.31]	
RH15D×11/16	17.46	100 [885]	26 [1.06]	10 [0.39]	
RH15D×3/4	19.05	140 [1239]	28 [1.10]	13 [0.51]	

Accessories



The Relationship between Interchangeable Heads and Torque Wrenches

Tohnichi's interchangeable head wrenches have specific diameter round ends that fit into corresponding head base openings. Head and wrench model names include the diameter sizes so heads can be matched to wrenches that will accept those heads.

For example: SH15D×17 will fit on CL100N×15D

A variety of different head types (SH, RH, QH, RQH, FH, DH, AH and SP-N) can be used on one wrench or different types of wrenches such as CL (for tightening) and CEM3 (for inspection) can use the same head that has the corresponding diameter size.

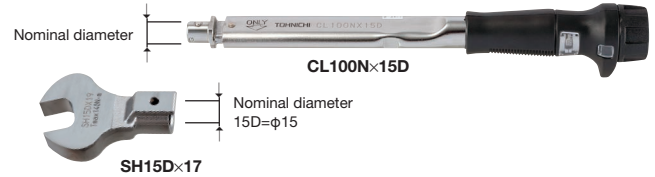

QH Ratchet Head

RoHS

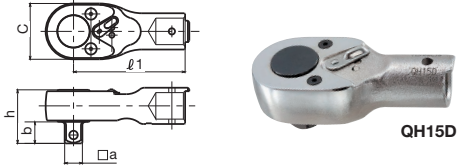

As the QH type ratchet heads need only small swing for tightening, they suit for operations in narrow spaces.

Tohnichi Head Size	Model	Dimensions			
		Sq. Drive a [mm]	Outside Width c [mm]	h [mm]	b [mm]
8D	QH8D	6.35	23	17.5	7.5
10D	QH10D-1/4		26	18.5	
	QH10D	9.53	32	22	11
12D	QH12D			25.6	
15D	QH15D-3/8			30.5	
	QH15D	12.7	40	33.5	14
19D	QH19D			38.4	
22D	QH22D-1/2	19.05	51	41.5	15.5
	QH22D			46.5	
27D	QH27D			49.7	
32D	QH32D	25.4	74	55.7	26.5

Note

- For the model having 25.4mm square drive, use a through-hole socket.
QH15D-3/8 Tmax 100N-m
QH22D-1/2 Tmax 280N-m
- Ratchet protective cover is available. Refer to page 46.

DH Square Drive Head

RoHS

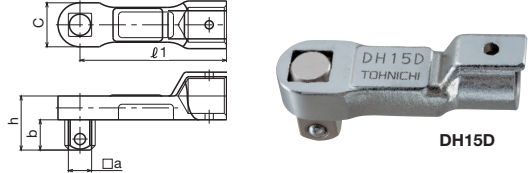

The DH square drive heads are the standard interchangeable head. They are useful when tightening a large number of matching screws with a common torque wrench. It is recommended to keep one set. They are used with sockets.

Tohnichi Head Size	Model	Dimensions			
		Sq. Drive a [mm]	Outside Width c [mm]	h [mm]	b [mm]
10D	DH10D	9.53	18	22.5	13
12D	DH12D			23	
15D	DH15D	12.7	22	29.5	16.5
19D	DH19D			24	
22D	DH22D			34	
27D	DH27D	19.05	42	44.5	23.5
32D	DH32D			25.4	

Note DH32D is a through hole type.

RQH Female Ratchet Head

RoHS

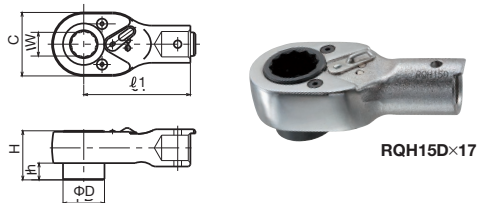

As the RQH type ratchet heads need only small swing for tightening, they suit for operations in narrow and low ceiling spaces.

Tohnichi Head Size	Model (Body Size × Width)	Dimensions			
		D [mm]	Outside Width C [mm]	H [mm]	h [mm]
12D	RQH12D×12	20.5	32	24.1	
	RQH12D×14				
15D	RQH15D×14	24.5	37.5	29	
	RQH15D×17				
19D	RQH19D×17	31	45	28	10
	RQH19D×19				
	RQH19D×22				
22D	RQH22D×22	35.2	51	35	
	RQH22D×24				

HH Hex Head

RoHS



The HH hex-head is for hex. socket head cap screws.

Tohnichi Head Size	Model (Body Size × Width)	Dimensions			
		Outside Width C [mm]	t [mm]	m [mm]	φd2 [mm]
8D	HH8D	12	14.5	-	-
	HH10D×5	11			
10D	HH10D×6	12	8		
	HH10D×8	15			
12D	HH12D×5	11		19	7
	HH12D×6	14	10		
	HH12D×8	15			
15D	HH15D×10	17			
	HH15D×8	14			
	HH15D×10	17		21	
	HH15D×12	20			
19D	HH15D×14	21.5			
	HH19D×10	17	13		8.5
	HH19D×12	21.5			
	HH19D×14	23		23	
22D	HH19D×17	27			
	HH19D×19	29			
	HH22D×12	19.5			
	HH22D×14	27			
22D	HH22D×17	30	17	26	10
	HH22D×19	32			
	HH22D×22	35			

Note

- To be used with hex. key inserted.
- HH8D is not used with hex. key but interchangeable bit.



Bits are sold separately. Refer to page 11.

Auxiliary Equipment

To facilitate effective and convenient use of Tohnichi products, a number of auxiliary parts and special tools are available (Some torque tools are provided with the necessary auxiliary parts). We are ready to manufacture custom-made parts and tools to meet your requirements.

For Torque Wrench

QH/QL/PQL/QSP RATCHET PROTECTIVE COVER

Fit on your Tohnichi Ratchet Head to protect your work

NEW



Part #	Applicable Interchangeable Head & Model	
870	QH8D	QL/PQL2N-15N(-MH), QSP1.5N4-12N4
871	QH10D	QL/PQL/QSP25N(-MH)
872	QH12D	QL/PQL/QSP50N(-MH)
873	-	QL/PQL/QSP100N4(-MH)
874	QH15D	QL/PQL/QSP140N(-MH)
875	QH19D	QL/PQL/QSP200N4(-MH)
876	RQH19D	-
877	-	QL/PQL/QSP280N4(-MH)
878	QH22D	QL/PQL/QSP420N

TiQLE ADJUSTING TOOL FOR TiQLE

This tool is used to set the torque of the large TiQLE adjustable wrenches.



Part #	Applicable Model
301	TIEQLE750N-TIEQLE1400N

SP THRUSTRING TOOL FOR SP

This tool is used to set the torque of preset types SP, RSP, QSP and CSP torque wrenches.



Part #	Tool #	Applicable Model
310	A-1	QSP/CSP1.5N-QSP/CSP6N
311	A-2	SP2N-SP19N, QSP/CSP12N, QSP/CSP25N
312	A-3	SP38N, SP67N, QSP/CSP50N-QSP/CSP140N, BQSP/BCSP50N-
313	A-4	SP120N-SP310N, QSP200N-QSP280N
314	A-5	QSP/CSP420N, BQSP/BCSP420N5
315	A-6	SP420N, SP560N

QSP3 ADJUSTING TOOLS FOR QSP3



Part #	Dimensions [mm]	Applicable Model
931	2.5 x 1.5 x 6	QSP/CSP25N3, QSP1.5N4-12N4 BQSP/BCSP25N5, CSP1.5N4-CSP12N4
930	4 x 2.5 x 8	QSP/CSP50N3-QSP/CSP280N3 QSP100N4, QSP200N4 BQSP/BCSP50N5-BQSP/BCSP280N5 SP/RSP120N2-310N2

DB TOOL SET FOR DB

This set of pliers is used to adjust the torque for dial type torque wrenches and torque checkers.



Part #	Applicable Model
316	DB, DBE, CDB-S, T-S, DOT

CARRYING CASE



842



846

Part #	Dimensions [mm]	Weight [kg]
842	QL50N, QL50N-MH, MTQL40N, MTQL70N, QL100N4-MH CL50N (x12D/15D), CL50N (x12D/15D)-MH, CL100Nx15D-MH (H60 x W400 x D70)	0.25
843	QL140N, QL140N-MH, MTQL140N, QL200N4, QL200N4-MH CL140Nx15D, CL140Nx15D-MH, CL200Nx19D, CL200Nx19D-MH (H60 x W520 x D80)	0.36
846	QL140N and below, QL140N-MH and below, MTQL140N and below, CL200Nx19D, CL200Nx15D-MH, CL200Nx19D-MH and below (H170 x W500 x D100)	1.0
847	QL280N, QL280N-MH and below CL280Nx22D, CL280Nx22D-MH and below (H170 x W740 x D100)	1.6

For Torque Screwdriver

LTD, RTD ADJUSTING TOOL FOR LTD/RTD

This tool is used to adjust the torque of LTD and RTD torque screwdrivers.



Part #	Applicable Model
51	LTD/RTD15CN, LTD/RTD30CN
46	LTD/RTD60CN
47	LTD/RTD260CN
48	LTD/RTD500CN
49	LTD/RTD1000CN
1046	LTD/RTD120CN

LTD TIGHTENING TOOL FOR LTD

This tool makes tightening with large LTD much easier.



Part #	Applicable Model
31	LTD/RTD/NTD/RNTD500CN FTD400CN
32	LTD/NTD1000CN FTD8N, FTD16N
40	LTD2000CN

LTD, RTD PRESET HOOK SPANNER FOR LTD/RTD

This tool makes it easier to set the torque for mid. to large capacity LTD and RTD screwdrivers.



Part #	Applicable Model
52	LTD/RTD260CN
53	LTD/RTD500CN
54	LTD1000CN
55	LTD2000CN

NTD, RNTD ADJUSTING BAR FOR NTD/RNTD

This tool is used to set the torque of preset types NTD and RNTD screwdrivers.



Part #	Applicable Model
42	NTD/RNTD15CN-NTD/RNTD120CN
43	NTD/RNTD260CN
44	NTD/RNTD500CN-NTD/RNTD1000CN

TORQUE SCREWDRIVER ADAPTER

This accessory is used with TME2 and TM torque meters to test UNITORK and torque screwdrivers.



Part #	Applicable Model
30	LTD/RTD/NTD/RNTD FTD50CN-FTD400CN

Lubricant for repairing torque products EVERTORQUE

Model	Part #
EVERTORQUE	830



RoHS



Applicable Models and Parts

	Applicable Model	Applicable Part
Click Type Torque Wrench	QL, QLE, CL, CLE, PQL, PCL, YCL etc.	Thrusting; Steel Ball Scale Piece, Adjusting Screw; Thread
	WQL	Thrusting; Steel Ball Scale Piece, Adjusting Screw; Thread Screw Knob, Protector; Joint
	MPQL	Thrusting; Steel Ball Scale Piece, Adjusting Screw; Thread Ratchet, Marker Pipe; Joint
Click Type Torque Screwdriver	RTD, RNTD	Main Shaft, Toggle Sheet; Serration
	RTD, LTD, BMLD	Case, Adjusting Piece; Thread







Connecting Cable

* The cable length is 2m.

■ EPP16M3 Printer Connecting Cable



Part #	Applicable Models	Figure	Plug
383	DOT3-G (P.54), LC3-G (P.56), TDT3-G (P.57), TME2 (P.60), CD5 (P.66)		D-SUB 9 Pin Female
575	CEM3-G/CEM3-P (P.36), CTA2 (P.24), R-DT999 (P.66), CTB2-G (P.37)		D-SUB 9 Pin Female

■ PC Connecting Cable



Part #	Applicable Model	Figure	Plug
575	CEM3-G/CEM3-P (P.36), CTA2 (P.24), R-DT999 (P.66), CTB2-G (P.37)		D-SUB 9 Pin Female
584	CEM3-G/CEM3-P (P.36), CTA2 (P.24), R-DT999 (P.66), CTB2-G (P.37)		USB A type
585	CPT-G (P.23)		D-SUB 9 Pin Female
383	DOT3-G (P.54), LC3-G (P.56), TDT3-G (P.57), TME2 (P.60), CD5 (P.66)		D-SUB 9 Pin Female
384	STC2-G (P.10), ST3-G (P.56), ATGE-G (P.58), BTGE-G (P.59)		USB A type
385	LC3-G (P.56), TDT3-G (P.57)		USB A type

Quick Charger, Battery Pack, AC Adapter



■ Quick Charger



Model	Applicable Model	Figure
RoHS BC-3-G	CEM3-G/CEM3-P (P.36), CTA2 (P.24) CTB2-G (P.37) (100-240V)	
RoHS BC-4-2	ST3-G (P.56)	

■ Battery Pack

Model	Applicable Model	Figure
BP-5	CEM3-G/CEM3-P (P.36) CTA2 (P.24), CTB2-G (P.37)	
BP-7	STC2-G (P.10)	
RoHS BP-100-3	DOT3-G (P.54), LC3-G (P.56), TDT3-G (P.57), TME2 (P.60), CD5 (P.66)	

■ AC Adapter

Model	Applicable Model	Figure
RoHS BA-6	DOT3-G (P.54), LC3-G (P.56), TDT3-G (P.57), CD5 (P.66)	
RoHS BA-5	ATGE-G (P.58), BTGE-G (P.59)	

Model	Applicable Model	Figure
RoHS BA-4	TME2 (P.60)	
BA-7	STC2-G (P.10)	



AUR

UNITORK (Pistol Type Pneumatic Torque Screwdriver)

Direction



AUR12.5N

Assembly

Pistol

Pneumatic

Graduation

Trigger

RoHS

- High speed and high accuracy tightening
- Easy torque adjustment by scale with key

Accuracy ±5%

S.I. Model	Torque Range [N·m]		Metric Model	Torque Range [kgf·cm]		American Model	Torque Range [lbf·in]		Free Speed [r.p.m.]	Air Pressure [MPa]	Hose in Dia. [mm]	Standard Accessory Bit Ⓢ	Weight [kg]
	Min.-Max.	Grad.		Min.-Max.	Grad.		Min.-Max.	Grad.					
AUR5N	2-5	0.1	AU50R	20-50	1	AU50R-A	15-45	1	2100	0.5	φ10	#3	1.5
AUR12.5N	5-12.5	0.25	AU125R	50-125	2.5	AU125R-A	37.5-112.5	2.5	800				
AUR25N	10-25	0.5	AU250R	100-250	5	AU250R-A	75-225	5	400				

Note

1. AUR5N has #3 bit (6.35 HEX) with a double bit. Any other bits are available in the local market.
2. AUR12.5N and AUR25N have a fixed 9.53mm square drive. Use pneumatic sockets only.

Standard Accessories

1. Torque adjusting key
2. Supportive Handle (for AUR(LS) 25N)
3. W12 Open ended spanner (for AUR(LS) 25N)

AURLS

- AUR style with limit switch output
- Ideal for torque verification (Pokayoke) assembly processes

Accuracy ±5%

S.I. Model	Torque Range [N·m]		Metric Model	Torque Range [kgf·cm]		American Model	Torque Range [lbf·in]		Free Speed [r.p.m.]	Air Pressure [MPa]	Hose in Dia. [mm]	Standard Accessory Bit Ⓢ	Weight [kg]
	Min.-Max.	Grad.		Min.-Max.	Grad.		Min.-Max.	Grad.					
AURLS5N	2-5	0.1	AU50RLS	20-50	1	AU50RLS-A	15-45	1	2100	0.5	φ10	#3	1.5
AURLS12.5N	5-12.5	0.25	AU125RLS	50-125	2.5	AU125RLS-A	37.5-112.5	2.5	800				
AURLS25N	10-25	0.5	AU250RLS	100-250	5	AU250RLS-A	75-225	5	400				

POKA Patrol (Count Checker)

CNA-4mk3

Refer to page 31.



* Sold Separately

HAT

HANDYTORK (Battery Operated Torque Screwdriver)

Direction



HAT25N

Assembly

Pistol

Re-Chargeable

Graduation

Trigger

- Easy calibration check with standard torque wrench tester
- Available with reverse and as FH version

Accuracy ±5%

S.I. Model	Torque Range [N·m]		Free Speed [r.p.m.]	Voltage DC [V]	Square Drive [mm]	Weight [kg]
	Min.-Max.	Grad.				
HAT25N	10-25	0.5	700	12	9.5	1.8
HATR25N			140			

Note

1. Torque accuracy is based upon static torque measured by torque wrench tester.
2. HATR/HATRFH has a reverse mode function.
3. HATFH/HATRFH is error-proofing (Pokayoke) type, and it can be used only with R-FH256 receiver (sold separately) as count verification system.
4. Use pneumatic sockets only.
5. HAT battery and battery charger are optional.
6. It is designed for 100V usage only.

Standard Accessories

1. W4 hex key
2. Supportive handle (for HAT25N, HATR25N, HATFH25N, HATRFH25N)

HATFH

- Wireless error-proofing (Pokayoke) version of HAT
- Tightening completion signal output to eliminate missed tightening

Accuracy ±5%

S.I. Model	Torque Range [N·m]		Free Speed [r.p.m.]	Voltage DC [V]	Square Drive [mm]	Weight [kg]
	Min.-Max.	Grad.				
HATFH25N	10-25	0.5	700	12	9.5	1.8
HATRFH25N			140			

HAT Optional Accessories



BP-12

Battery

Model	Description
BP-12	DC 12V



BC-1

Battery Charger

Part #	Model
820	BC-1 (AC100V)

POKA Patrol (Count Checker)

CNA-4mk3

Refer to page 31.



* Sold Separately

U/UR

UNITORK (Straight & Pistol Type Pneumatic Torque Screwdriver)

Assembly

Straight/Pistol

Pneumatic

Graduation

Trigger/Lever

RoHS

Direction

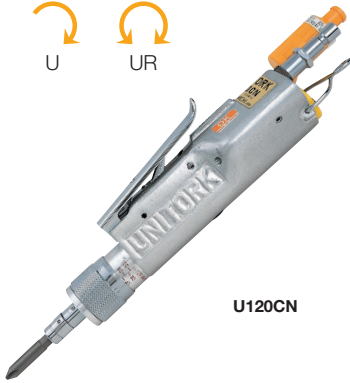

U120CN

- Accurate and stable tightening for small size screws
- Lever activated

Accuracy ±5%

S.I. Model	Torque Range [cN·m]		Metric Model	Torque Range [kgf·cm]		American Model	Torque Range [lbf·in]		Free Speed [r.p.m]	Air Pressure [MPa]	Hose Dia. [mm]	Weight [kg]	Standard Accessory Bit ⊕
	Min.-Max.	Grad.		Min.-Max.	Grad.		Min.-Max.	Grad.					
U30CN	10-30	0.5	U3	1-3	0.05	U3-A	1-3	0.05	1600	0.4		0.32	#0
U60CN	20-60	1	U6	2-6	0.1	U6-A	2-5	0.1	1700	0.5	φ5	0.42	#1
U120CN	40-120	2	U12	4-12	0.2	U12-A	4-10	0.2	1400		0.48	#2	
U250CN	100-250	5	U25	10-25	0.5	U25-A	8-22	0.5	1200	0.6		0.75	
U500CN	200-500	10	U50-2	20-50	1.0	U50-2-A	15-45	1.0	950	0.5	φ6	1.35	#3
U1000CN	400-1000		U100	40-100		U100-A	30-90		700	0.6	2.0		
ULR120CN	40-120	2	U12LR	4-12	0.2	U12LR-A	4-10	0.2	1300	0.5	φ5	0.56	#2
ULR250CN	100-250	5	U25LR	10-25	0.5	U25LR-A	8-22	0.5	1000	0.6	φ6	0.95	#3
UR500CN	200-500	10	U50R	20-50	1.0	U50R-A	15-45	1.0	950			1.45	

- Note**
1. U1000CN has a fixed square drive (9.53mm). Use socket bits or bit holders for this model.
 2. U500CN, 1000CN, and UR500CN are pistol type with trigger mechanism.
 3. Standard bits available in the local market can be used.

- Standard Accessories**
1. One Touch Joint #130 (For U30CN-U250CN, ULR120CN and ULR250CN)
 2. Bit holder (For U1000CN only)

U/UR Optional Accessories



One Touch Joint (Female)
Joint to connect UNITORK to air hoses

Part #	Applicable Model	Size
130	U30CN-U250CN	PF 1/4 Female
131		PF 1/4 Male
132		φ8 Hose Joint

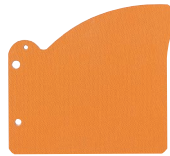

Hand Cover
For hand slip protection

Part #	Applicable Model
150	U30CN-U120CN
151	U250CN



Torque-fix
For torque adjustment

Part #	Applicable Model
145	U30CN-U120CN
146	U250CN
147	U500CN, UR500CN

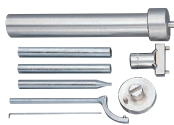

Tool Kit
Tools for disassembly/assembly for UNITORK

Part #	Applicable Model
160	U30CN-U250CN
161	U250CN
162	U500CN, UR500CN
163	U1000CN



A/AC2

Semi-Automatic Airtork

Direction

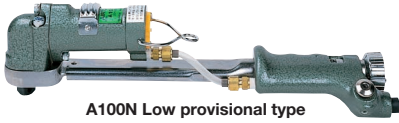

A100N Low provisional type



A180N Low provisional type



AC50N2 High provisional type



ACLS100N2 High provisional with limit switch type

Assembly

Angle

Pneumatic

Graduation

Push button

RoHS

- Pneumatic motor mounted on torque wrench
- After provisional tightening by an air motor at high speed, final tightening is performed manually.
- A: Low provisional torque type
- AC: High provisional torque type

Accuracy $\pm 3\%$

S.I. Model	Torque Range [N·m]		Metric Model	Torque Range [kgf·cm]		American Model	Torque Range [lbf·in/lbf·ft]		Max.Provisional Tightening Torque [N·m]	Free Speed [r.p.m.]	Air Pressure [MPa]	Hose Dia. [mm]	Overall Length [mm]	Square Drive [mm]	Weight [kg]
	Min.-Max.	Grad.		Min.-Max.	Grad.		Min.-Max.	Grad.							
A10N	3-10	0.1	A100	30-100	1	A100-A	30-90	1	1.8	750			278	9.5	1.0
A25N	5-25	0.25	A225	50-250	2.5	A225-A	50-200	2.5							
A50N	10-50	0.5	A450	100-500	5	A450-A	100-400	5							
A100N	20-100	1	A900	200-1000	10	A900-A	15-65	1	2.5	800		φ5	340	12.7	1.43
A180N	40-180	2	A1800	400-1800	20	A1800-A	30-130	2							
NEW	AC25N2	5-25	0.25	AC250M2	50-250	2.5	AC200I2-3/8	50-200	2.5	11	1000		293	9.5	1.0
NEW	AC50N2	10-50	0.5	AC500M2	100-500	5	AC400I2-3/8	100-400	5						
NEW	-	-	-	-	-	-	AC800I2-3/8	200-800	10	17.5	900		334	9.5	2.0
NEW	AC100N2	20-100	1	AC1000M2	200-1000	10	AC75F2-3/8	15-75	1						
NEW	AC180N	40-180	2	A1800C	400-1800	20	AC130F-4A	30-130	2	19	800		489	12.7	3.3

- Note**
1. Rated voltage of the limit switch is AC/DC 30V, below 1A.
 2. Use pneumatic sockets only.
 3. S.Q. Drive Through Hole

ALS/ACLS2

- A/AC style with limit switch output
- Ideal for torque verification (Pokayoke) assembly processes

Accuracy $\pm 3\%$

S.I. Model	Torque Range [N·m]		Metric Model	Torque Range [kgf·cm]		Max.Provisional Tightening Torque [N·m]	Free Speed [r.p.m.]	Air Pressure [MPa]	Hose Dia. [mm]	Overall Length [mm]	Square Drive [mm]	Weight [kg]
	Min.-Max.	Grad.		Min.-Max.	Grad.							
ALS10N	3-10	0.1	A100LS	30-100	1	1.8	750		φ5	278	9.5	1.7
ALS25N	5-25	0.25	A225LS	50-225	2.5							
ALS50N	10-50	0.5	A450LS	100-500	5							
NEW	ACLS25N2	5-25	0.25	ACLS250M2	50-250	2.5	11	1000		293	1.7	1.2
NEW	ACLS50N2	10-50	0.5	ACLS500M2	100-500	5						
NEW	ACLS100N2	20-100	1	ACLS1000M2	200-1000	10	17.5	900	φ6	334	12.7	2.2
NEW	ACLS180N	40-180	2	A1800CLS	400-1800	20	19	800				

AS

Fully-Automatic Airtork

Direction



AS12N



ASH80N

AS optional Accessories



Spanner (for disassembly/assembly)

Part #	Applicable Model
170	AS



Torque Adjustment Key

Part #	Applicable Model
140	AS

Assembly

Angle

Pneumatic

Graduation/Preset

Lever

RoHS

- Pneumatic right angle style
- Speed tightening with shut off at final torque set
- ASH: High air pressure, ASL: Low air pressure

Accuracy $\pm 5\%$

S.I. Model	Torque Range [N·m]		Metric Model	Torque Range [kgf·cm]		Free Speed [r.p.m.]	Air Pressure [MPa]	Hose Dia. [mm]	Overall Length [mm]	Square Drive [mm]	Weight [kg]
	Min.-Max.	Grad.		Min.-Max.	Grad.						
AS12N	6-12	0.2	A120S	60-120	2	1000	0.5		359		1.9
ASH40N	20-40		A400SH	200-400		2000			477	9.5	2.6
ASH60N	30-60		A600SH	300-600		1330	0.6		484		2.8
ASH80N	40-80		A800SH	400-800		1000		592	12.7	3.2	
ASH120N	60-120	Preset	A1200SH	600-1200	Preset	640		φ12	662		4.1
ASL30N	15-30	Type	A300SL	150-300	Type	1700			477	9.5	2.6
ASL45N	22.5-45		A450SL	225-450		1130	0.45		484		2.8
ASL60N	30-60		A600SL	300-600		850		592	12.7	3.2	
ASL90N	45-90		A900SL	450-900		540		662		4.1	

- Note**
1. AS12N is Adjustable style having a graduated scale.
 2. Other AS models are Preset style. Please specify the required set torque when ordering. (Ex. ASH40N \times 30N·m)
 3. Use pneumatic sockets only.
 4. S.Q. Drive Through Hole

- Standard Accessories**
1. Torque adjustment key
 2. Spanner

AP

Fully-Automatic Airtork

Direction

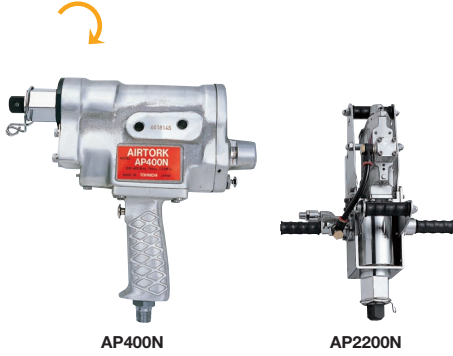

AP400N

AP2200N

Assembly

Pistol

Pneumatic

Graduation

Trigger/Lever

RoHS

- For large bolt tightening
- Automatic shut off at final torque set

Accuracy ±5%

S.I. Model	Torque Range [N-m]		Metric Model	Torque Range [kgf-m]		American Model	Torque Range [lbf-ft]		Free Speed [r.p.m]	Air Pressure [MPa]	Hose Dia. [mm]	Overall Length [mm]	Square Drive [mm]	Reaction Arm (Sold Separately)	Weight [kg]
	Min.-Max.	Grad.		Min.-Max.	Grad.		Min.-Max.	Grad.							
AP220N	100-220	10	AP22	10-22	1	AP160F	80-160	5	277			275	19.0	SA400N/UA450N	4.7
AP400N	200-400		AP40	20-40		AP300F	150-300	10	175						
AP700N	300-700	20	AP70	30-70	2	AP500F	220-500	10	79	0.5	φ12	364	25.4	SA700N/UA900N	6.7
AP1200N	600-1200	50	AP120	60-120	5	AP900F	450-900	25	46			375		SA1200N/UA1800N	8.1
AP2200N	1000-2200		AP220	110-220		AP1600F	800-1600	50	19.2			508	31.75	UA3000N	15
AP4000N	2000-4000	100	AP400	200-400	10	AP3000F	1500-3000	100	12			541	38.1	UA4500N	22

- Note**
1. Reaction arm, such as UA or SA, must be used when operating AP models in order to absorb reaction force.
 2. Use pneumatic sockets only.
 3. S.Q. Drive Through Hole

Standard Accessories W5 hex key

DAP

Fully-Automatic Electric Torque Wrench

Direction

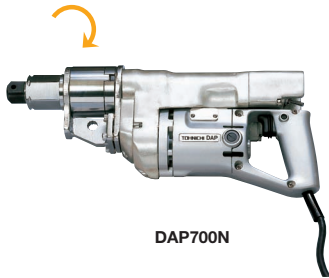

DAP700N

Assembly

Pistol

Electric Power

Graduation

Trigger

- Electric version of AP

Accuracy ±5%

S.I. Model	Torque Range [N-m]		Metric Model	Torque Range [kgf-m]		Free Speed [r.p.m]	Voltage AC [V]	Overall Length [mm]	Square Drive [mm]	Reaction Arm (Sold Separately)	Weight [kg]
	Min.-Max.	Grad.		Min.-Max.	Grad.						
DAP220N	100-220	10	DAP22	10-22	1	314	AC100V ±10%	318	19.0	SA400N/UA450N	5.4
DAP400N	200-400		DAP40	20-40		199					
DAP700N	300-700	20	DAP70	30-70	2	90	50/60Hz	400	25.4	SA700N/UA900N	8.2
DAP1200N	600-1200	50	DAP120	60-120	5	53		418		SA1200N/UA1800N	9.4

- Note**
1. DAP has 2 types, A-type for clockwise tightening, and B-type for clockwise tightening + reverse mode. Torque control is available only for clockwise direction for both type.
 2. Power cable is 2.5m length.
 3. Reaction arm is optional.
 4. Reaction arm is a must for using this model.
 5. Reaction arm, such as UA or SA, must be used when operating DAP models in order to absorb reaction force.
 6. Use pneumatic sockets only.
 7. S.Q. Drive Through Hole
 8. It is designed for 100V usage only.

Standard Accessories W5 hex key

AP/DAP Optional Accessories

SA

Shell Arm
Light weight reaction arm

RoHS



Model	Standard Socket Length [mm]
SA400N	50
SA700N	62
SA1200N	62

UA

Universal Arm
Heavy duty reaction arm

RoHS

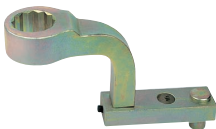

Model	Weight [kg]
UA450N	1.2
UA900N	2.6
UA1800N	4
UA3000N	7.2
UA4500N	10.9
UA9000N	18
UA18000N	-

DECA 10:1 Ratio Torque Multiplier

RoHS

- Multiplied torque output by 10
- Ideal for applying high torque values with less force



DECA900N

Body + Universal Arm



Universal Arm

Accuracy ±5%

Model	Output Torque			Torque Ratio	Dimension [mm]				Weight [kg]	Applicable Universal Arm
	[N-m]		[kgf-m]		Overall Length	Dia.	Output Sq. Drive	Input Sq. Drive		
	Min.-Max.	Min.-Max.	Min.-Max.							
DECA450N	90-450	9-45	65-325	10:1	195	52	19.0	9.5	2	UA450N
DECA900N	180-900	18-90	130-650		541	63	25.4	12.7	3.4	UA900N
DECA1800N	360-1800	36-180	260-1300		270	78	31.75	19.0	5.7	UA1800N
DECA3000N	600-3000	60-300	434-2170		324	95	38.1	25.4	10	UA3000N
DECA4500N	900-4500	90-450	650-3250		367	110	50.8	31.75	12.5	UA4500N
DECA9000N	1800-9000	180-900	1300-6500		464	140	63.5	38.1	34	UA9000N
DECA18000N	3600-18000	360-1800	2600-13000	540	172			60	UA18000N	

- Note**
1. Universal Arm is optional.
 2. DECA9000N and DECA18000N are supplied upon request.
 3. S.Q. Drive Through Hole

Standard Accessories

1. Metal Case (for DECA450N-DECA900N only)
2. Portable Handle (for DECA4500N-DECA9000N only)
3. Metal Case Caster (for DECA18000N only)



ME/MC

Multiple Unit
(Pneumatic
Straight Style)

Direction



ME126N

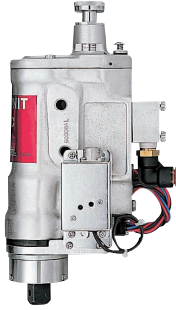

MC400N-TC

Automatic **Straight** **Pneumatic** **Graduation** **Master Valve Operation** **RoHS**

- Several units used simultaneously with loader
- Fully automatic tightening for complex bolt configurations

Accuracy ±5%

S.I. Model	Torque Range [N·m]		Metric Model	Torque Range [kgf-cm/kgf-m]		American Model	Torque Range [lbf-in/lbf-ft]		Free Speed [r.p.m]	Air Pressure [Mpa]	Hose Dia. [mm]	Overall Length [mm]	Square Drive [mm]	Weight [kg]
	Min.-Max.	Grad.		Min.-Max.	Grad.		Min.-Max.	Grad.						
ME25N	10-25		0.5	M250E2	100-250	5	M250E2-A	90-220	5	1050		420.6 (457.6)	9.5	4.7
ME45N	20-45			M450E2	200-450		M450E2-A	200-400		540				
ME80N	35-80	1		M800E2	350-800	10	M800E2-A	310-700	10	310	0.4	φ7.5	424 (461)	12.7
ME126N	50-126	2		M1260E2	500-1260	20	M1260E2-A	35-90	2	200				5.7
MC220N	100-220			M22C	10-22		M22C-A	80-160		277				
MC400N	200-400	10		M40C	20-40	1	M40C-A	150-300	10	175			287.5	19.0
MC700N	300-700	20		M70C	30-70	2	M70C-A	220-500	20	79			376	6.7
MC1200N	600-1200	50		M120C	60-120	5	M120C-A	450-900	50	46	0.5	φ8	388	25.4
MC2200N	1000-2200			M220C	100-220		M220C-A	700-1600		19.2			491	31.75
MC4000N	2000-4000	100		M400C	200-400	10	M400C-A	1500-3000	100	12			522	38.1

- Note**
1. Overall length in () is the length with TC sensor.
 2. Auto-reverse/auto-reset functions.
 3. For designing a multi-spindle system, check the PCD, minimum distance between the spindles.
 4. Add "-TC" for sensor-equipped version.
 5. For first-time user, consult Tohnichi for assistance.

Standard Accessories Torque adjusting bar

MG/MF

Multiple Unit
(Pneumatic Straight
Style)

Direction

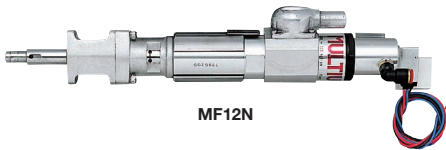

MF12N

Automatic **Straight** **Pneumatic** **Graduation** **Master Valve Operation** **RoHS**

- Several units used simultaneously with loader
- Fully automatic tightening for complex bolt configurations

Accuracy ±5%

S.I. Model	Torque Range [cN-m/N-m]		Metric Model	Torque Range [kgf-cm]		American Model	Torque Range [lbf-in]		Free Speed [r.p.m]	Air Pressure [Mpa]	Hose Dia. [mm]	Overall Length [mm]	Bit Holder [mm]	Weight [kg]
	Min.-Max.	Grad.		Min.-Max.	Grad.		Min.-Max.	Grad.						
MG120CN	40-120	1	M12G	4-12	0.1	M12G-A	4-10	0.2	720		φ5	287-		0.68
MG250CN	100-250	2.5	M25G	10-25	0.25	M25G-A	8-22	0.5	350			279	6.35	
MF6N	3-6	0.1	M60F	30-60	1	M60F-A	25-50	1	1000		φ6	411-		2.0
MF12N	6-12	0.2	M120F	60-120	2	M120F-A	50-100	2	500			403		

- Note**
1. MG/MF is 6.35 HEX bit holder type.
 2. For designing a multi-spindle system, check the PCD, minimum distance between the spindles.
 3. For first-time user, consult Tohnichi for assistance.

Standard Accessories Torque adjusting key

AME

Multiple Unit
(Pneumatic Right
Angle Style)

Direction



AME35N

Automatic **Angle** **Pneumatic** **Graduation** **Master Valve Operation** **RoHS**

- Ideal for automated tightening applications

Accuracy ±5%

S.I. Model	Torque Range [N·m]		Metric Model	Torque Range [kgf-cm]		Free Speed [r.p.m]	Air Pressure [Mpa]	Hose Dia. [mm]	Overall Length [mm]	Square Drive [mm]	Weight [kg]
	Min.-Max.	Grad.		Min.-Max.	Grad.						
AME25N	10-25		0.5	AM250E2	100-250	5	1200		369 (407)	9.5	2.6
AME35N	15-35			AM350E2	150-350		800		376 (414)		2.7
AME50N	20-50			AM500E2	200-500		600	0.5	484 (522)	12.7	2.9
AME70N	30-70	1		AM700E2	300-700	10	380		554 (592)		3.6

- Note**
1. Auto-reverse/auto-reset functions.
 2. For designing a multi-spindle system, check the PCD, minimum distance between the spindles.
 3. Add "-TC" for sensor-equipped version.
 4. For first-time user, consult Tohnichi for assistance.

Standard Accessories Torque adjusting bar

DCME Multiple Unit (Electric Straight Style)

Direction

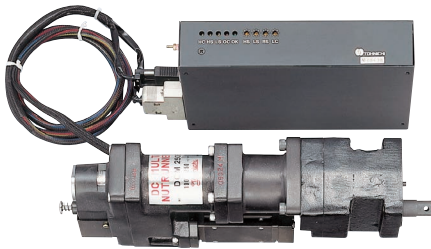

DCME25N

Automatic **Straight** **Electric Power** **Graduation** **Switch Signal**

- Electric version of ME
- Built-in brushless motor allows for noiseless fastening.

Accuracy ±5%

S.I. Model	Torque Range [N·m]		Metric Model	Torque Range [kgf·cm]		Free Speed [r.p.m]	Voltage [AC V]	Overall Length [mm]	Square Drive [mm]	Weight [kg]
	Min.-Max.	Grad.		Min.-Max.	Grad.					
DCME25N	10-25	0.5	DCM250E	100-250	5	1050	Single	302 (339)	9.5	5
DCME45N	20-45	1	DCM450E	200-450	10	540	Phase 200			5.5
DCME80N	36-80	2	DCM800E	350-800	20	310	50/60Hz	305 (342)	12.7	
DCME125N	50-125	5	DCM1250E	500-1250	50	200	(100)			6.0

- Note**
1. For designing a multi-spindle system, check the PCD, minimum distance between the spindles.
 2. Specify the electric voltage.
 3. Add "-TC" for sensor-equipped version.
 4. For first-time user, consult Tohnichi for assistance.

- Standard Accessories**
1. Driver Unit (DR-DCME)
 2. W5 hex key

Power Supply (Sold separately)

Model	Powr Source AC (V)	
PS-DCME	AC200V (AC100V)	DC140V AC15V

Note Specify the voltage when ordering

Optional Accessories for Multiple Unit



Handle Valve (supportive handle)

Part #	Type	Air Outlet	Overall Length [mm]	Application
188	Handle Valve	3/8	135	For Direct Connection
189	Handle Valve	1/8	125	Master Valve
187	Handle Assist	-		-



Switch Handle (Switch)

Part #	Type	Application
331	Start Switch Handle	Multiple Unit Start Switch
332	Reset Switch Handle	Reset Switch
333	Quick Reverse Handle	Emergency Reset Switch



Master Valve

Part #	Application	Air Outlet × Air Supply × Number of Branch
		(ΦD) × (φd) × (n)
195	MF	1/2 × 1/4 × 4
196	ME	1/2 × 1/4 × 6
197	MC	3/4 × 3/8 × 2
198		1 × 3/8 × 4
199		1 × 3/8 × 6



Slide Drive (for ME, DCME)

Model
FDME25N
FDME80N
FDME126N
FDME400N
FDME1200N



Slide Drive (for MC)

Model
FDMC400N
FDMC1200N



Torque Sensor

Model	Applicable Model
TC-ME2	ME
TC-MCA	MC220N, MC400N
TC-MCB-2	MC700N
TC-MCB	MC1200N

Related Products

Daily inspection/calibration devices for power torque tools



ST20N3-G

Torque checking for multi-spindle nut runners (P.56)



ST1000N3-G



TCF20N

Fixed typed torque sensor to calibrate power tools (P.61)



TCR18N

Rotary type torque sensor capable of measuring rotating objects (P.61)



CD5

Display of torque value measured by strain gauge sensor (P.66)



NOTE3-G

Digital Torque Wrench Tester

Calibration

Digital

Manual Handle

Direct Reading

RoHS

Direction



NOTE100N3-G



Accuracy $\pm 1\% + 1$ digit

Model	Torque Range												Torque Wrench Max. Effective Length [mm]	Inlet Drive [mm]	Weight [kg]	
	cN-m		N-m		kgf-cm		kgf-m		lbf-in		lbf-ft					
	Min.-Max.	1 digit	Min.-Max.	1 digit	Min.-Max.	1 digit	Min.-Max.	1 digit	Min.-Max.	1 digit	Min.-Max.	1 digit				
NOTE20N3-G	200.0-2000.0	0.5	2.000-20.000	0.005	20.00-200.00	0.05	-	-	18.00-180.00	0.05	-	-	-	-	9.5	-
NOTE50N3-G	-	-	5.00-50.00	0.01	50.0-500.0	0.1	-	-	44.0-440.0	0.1	3.60-36.00	0.01	410	-	11	-
NOTE100N3-G	-	-	10.00-100.00	0.02	100.0-1000.0	0.2	-	-	88.0-880.0	0.2	7.30-73.00	0.02	-	-	12.7	-
NOTE200N3-G	-	-	20.00-200.00	0.05	200.0-2000.0	0.5	-	-	170.0-1700.0	0.5	15.00-150.00	0.05	660	-	13	-
NOTE500N3-G	-	-	50.0-500.0	0.1	-	-	5.00-50.00	0.01	440-4400	1	36.0-360.0	0.1	1020	19.0	24	-
NOTE1000N3-G	-	-	100.0-1000.0	0.2	-	-	10.00-100.00	0.02	880-8800	2	73.0-730.0	0.2	1650	25.4	45	-

Note 1. Auto-zero adjustment function.
 2. Statistical function includes the number of sampling, max/min/mean values.

NOTE3-G-MD **RoHS**

NOTE3-G with Motor Driven Loading Device

Model
NOTE20N3-G-MD
NOTE50N3-G-MD
NOTE100N3-G-MD
NOTE200N3-G-MD
NOTE500N3-G-MD
NOTE1000N3-G-MD

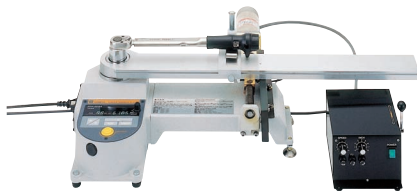

NOTE100N3-G-MD

NOTE3-G Standard Accessories

Model	Down Adapter (Female)		Hex Adapter (Male) [mm]	AC Adapter (Power supply)
	Part #	[mm]		
NOTE20N3-G	296/DA3-2 (P.67)	6.35	10, 13, 19	BA-6 (AC100-240V \pm 10%)
NOTE50N3-G				
NOTE100N3-G	277 (P.41)	9.5	12, 14, 17	
	297/DA4-3 (P.67)			
NOTE200N3-G	-	-	17, 22, 27/19, 24, 30	
NOTE500N3-G	-	-	22, 27, 29/30, 32, 36	
NOTE1000N3-G	299/DA8-6 (P.67)	19.0	34, 41/46, 50	

NOTE3-G Optional Accessories

Hex Adapter

Part #	Size [mm]
285	3/8-7-8-9
286	1/2-16-18-21
287	1/2-17-22-27
288	1/2-19-24-30

Connecting Cable (P.47)

Part #	Applicable Models
383	NOTE3-G \rightarrow PC, EPP16M3 (D-SUB 9 Pin Female)

Note 1. () shows pin shape of the connecting cables.
 2. Contact Tohnichi for other types of connecting cables.

Battery Pack (P.47)

Model
BP-100-3

Printer (P.67)

Model
EPP16M3

Data Filing System (P.66)

Model	Media
DFS	CD-ROM

DOT

Analog Torque Wrench Tester

Calibration

Dial Indicating

Manual Handle

Direct Reading

RoHS

Direction



DOT100N

Accuracy $\pm 2\%$

S.I. Model	Torque Range [N-m]		Metric Model	Torque Range [kgf-cm]		American Model	Torque Range [lbf-in/lbf-ft]		Torque Wrench Max. Effective Length [mm]	Inlet Drive [mm]	Weight [kg]	Standard Accessory	
	Min.-Max.	Grad.		Min.-Max.	Grad.		Min.-Max.	Grad.				Down Adapter (Female) [mm]	Hex Adapter (Male) [mm]
							lbf-in	lbf-in					
DOT35N	5-35.0	0.1	350DOT	50-350	1	DOT300I	50-300	1	-	9.5	-	#296 (6.3)	10, 13, 19
DOT50N	5-50.0	0.2	500DOT	50-500	2	DOT430I	50-430	2	410	8	-	#277 (6.4), #297 (9.5)	12, 14, 17
DOT100N	10-100.0	0.5	1000DOT	100-1000	5	DOT1000I	100-1000	5	-	12.7	-	-	-
						lbf-ft	lbf-ft						
DOT300N	30-300	1	3000DOT	300-3000	10	DOT200F	20-200	1	660	19	10	-	17, 22, 27, 19, 24, 30
DOT700N	70-700	2	7000DOT	700-7000	20	DOT500F	50-500	2	1260	25	25	-	22, 27, 29, 30, 32, 36

Note Measurement for clockwise direction only.

DOT-MD

DOT with Motor Driven Loading Device

S.I. Model	Metric Model	American Model
DOT35N-MD	350DOT-MD	DOT300I-MD
DOT50N-MD	500DOT-MD	DOT430I-MD
DOT100N-MD	1000DOT-MD	DOT1000I-MD
DOT300N-MD	3000DOT-MD	DOT200F-MD
DOT700N-MD	7000DOT-MD	DOT500F-MD

◆ Calibration Kit for NOTE3-G/DOT



* Sold separately. Refer to page 62.

TF Fully Automatic Digital Torque Wrench Tester

Direction



TF2000N

Accuracy $\pm 1\% + 1$ digit

Calibration **Digital** **Electric Power** **Direct Reading** **Fully Automatic**

- Tool Management System with computer
- Ideal for Calibration Labs
- Fully automatic testing, judging, and data processing

TF Standard Accessories

Hex Adapter, Ratchet Adapter, and Down Adapter

Model	Hex Adapter Dimensions [mm]	Ratchet Adapter Model	Down Adapter Model
TF200N	<input type="checkbox"/> 12.7-17, 22, 27 <input type="checkbox"/> 12.7-19, 24, 30 <input type="checkbox"/> 9.53-10, 13, 19 <input type="checkbox"/> 9.53-12, 14, 17	RA3mk2 RA4mk2	DA3-2 DA4-3
	<input type="checkbox"/> 19.05-W22, 27, 29 <input type="checkbox"/> 19.05-W30, 32, 36 <input type="checkbox"/> 9.53-W10, 13, 19 <input type="checkbox"/> 9.53-W12, 14, 17		
TF1000N	<input type="checkbox"/> 25.4-36, 46 <input type="checkbox"/> 25.4-41, 51 <input type="checkbox"/> 12.7-17, 22, 27 <input type="checkbox"/> 12.7-19, 24, 30 <input type="checkbox"/> 9.53-10, 13, 19 <input type="checkbox"/> 9.53-12, 14, 17	RA3mk2 RA4mk2 RA8mk2	DA3-2 DA4-3 DA8-6
	<input type="checkbox"/> 25.4-36, 46 <input type="checkbox"/> 25.4-41, 50 <input type="checkbox"/> 19.05-22, 27, 29 <input type="checkbox"/> 19.05-30, 32, 36 <input type="checkbox"/> 9.53-10, 13, 19 <input type="checkbox"/> 9.53-12, 14, 17		
TF2000N	<input type="checkbox"/> 38.1-W36, 46 <input type="checkbox"/> 38.1-W41, 50 <input type="checkbox"/> 25.4-W36, 46 <input type="checkbox"/> 25.4-W41, 50 <input type="checkbox"/> 19.05-W22, 27, 29 <input type="checkbox"/> 19.05-W30, 32, 36	RA6mk2 RA8mk2 RA12	DA6-4 DA8-6 DA12-8
	<input type="checkbox"/> 38.1-W36, 46 <input type="checkbox"/> 38.1-W41, 50 <input type="checkbox"/> 25.4-W36, 46 <input type="checkbox"/> 25.4-W41, 50 <input type="checkbox"/> 19.05-W22, 27, 29 <input type="checkbox"/> 19.05-W30, 32, 36		

Note Refer to page 67.

Calibration Kit for TF



* Sold separately. Refer to page 62.

Standard Accessories 2m x 2P Flat Type Plug

TF Specifications and Dimension

Model	CH	Torque Wrench Max. Effective Length [mm]	Inlet Drive [mm]	Dimensions [mm]			Weight [kg]
				Overall Length	Width	Height	
TF200N	1	1550	12.7	1860	550	930	240
	2	1480	9.53				
TF500N	1	1550	19.05	1860	550	930	315
	2	1480	9.53				
TF1000N	1	1650	25.4	2160	550	930	380
	2	1550	12.7				
	3	1480	9.53				
TF2000N	1	2150	25.4	2660	550	930	415
	2	1550	19.05				
	3	1480	9.53				
TF3000N	1	2650	38.1	3160	550	930	450
	2	2150	25.4				
	3	1550	19.05				

TF: The tester performs automatic measurement and judgment.

3 Types of Measurement:

- (1) Click type torque wrench measurement
- (2) Direct type reading torque wrench measurement
- (3) Manual measurement: free set measurement points, number of counts, and accuracy when checking unregistered wrenches, or single-value preset torque wrenches.

TCC2-G Digital Torque Wrench Tester

Direction



Accuracy $\pm 1\% + 1$ digit

Calibration **Digital** **Manual Handle** **Direct Reading**

- Torque calibrator with data management software with wide torque range
- Calibration, adjustment, and data management for torque wrenches
- Multiple measuring unit
- Slate PC controller

Model	CH	Torque Range [N-m]		Torque Range [kgf-cm]		Torque Range [lbf-in]		Torque Wrench Max. Effective Length [mm]	Inlet Drive [mm]	Dimensions [mm]			Weight [kg]
		Min.-Max.	1 digit	Min.-Max.	1 digit	Min.-Max.	1 digit			Overall Length	Width	Height	
TCC100N2-G	1	4-100	0.01	40-1000	0.1	35.5-885	0.1	575	12.7	714	388	375	35
	2	1-25	0.002	10-250	0.02	9-220	0.02	482	9.53				
TCC100N2-D-G	1	4-100	0.01	40-1000	0.1	35.5-885	0.1	575	12.7	714	388	375	35
	2	20-600 cN-m	0.05 cN-m	2-60	0.005	2-50	0.005	482	6.35				
TCC500N2-G	1	20-500	0.05	200-5000	0.5	180-4400	0.5	1035	19.05	1206	502	430	75
	2	4-100	0.01	40-1000	0.1	36-880	0.1	769	12.7				
TCC1000N2-G	1	50-1000	0.1	500-10000	1	445-8800	1	1700	25.4	1906	574	526	115
	2	20-500	0.05	200-5000	0.5	180-4400	0.5	1212	19.05				

TCC2-G Specifications

Display	10 inch slate PC
Tool Management Function	Torque wrench/driver registration date, measurement date memory (model, serial number, measurement point, measurement count, accuracy level, channel, measurer, past record) Maximum data amount (1000pcs worth) is based on testing torque wrenches of single force direction. When testing bi-direction torque wrenches such as BQSP, it will be less than 1000pcs)
Measurement Mode	Click mode / direct reading mode / manual mode
Zero Adjustment	Automatic (press C key)
Operation Temperature	[°C] 0 ~ 40 (no condensation)
Power	[V] 100 ~ 240V 50/60Hz

TCC2-G Standard Accessories

Model	Hex Adapter	DOWN ADAPTER	Others
TCC100N2-G	<input type="checkbox"/> 12.7-W10, 13, 19 <input type="checkbox"/> 12.7-W12, 14, 17	DA3-2 DA4-3	(1) Cradle for PC display (2) AC adapter for PC display (3) Power cable
TCC500N2-G	<input type="checkbox"/> 12.7-W10, 13, 19 <input type="checkbox"/> 12.7-W12, 14, 17 <input type="checkbox"/> 19.05-W17, 22, 27 <input type="checkbox"/> 19.05-W19, 24, 30		
TCC1000N2-G	<input type="checkbox"/> 19.05-W17, 22, 27 <input type="checkbox"/> 19.05-W19, 24, 30 <input type="checkbox"/> 25.4-W36, 46 <input type="checkbox"/> 25.4-W41, 50	DA4-3 DA6-4	
		DA6-4 DA8-6	

Note Refer to page 67.

Calibration Kit for TCC2-G

* Sold separately. Refer to page 62.

TDT3-G Digital Torque Screwdriver Tester

Direction



TDT600CN3-G with loading device (Model: STA)



TDT600CN3-G with loading device (Model: TDTLA3)
* Sold separately



TDT600CN3-G with loading device (Model: LTA)
* Sold separately

◆ Calibration Kit for TDT3-G



* Sold separately.
Refer to page 62.

Calibration

Digital

Manual Rotary

Direct Reading

Loading Device

RoHS

- Ideal for testing click and dial indicating torque screwdrivers
- Newly added judgment function and USB output
- Multiple units of measure through keypad setup
- Optional TDTLA3 for testing small torque wrenches and LTA for indicating type torque screwdrivers

Accuracy $\pm 1\% + 1$ digit

Model	Torque Range								Inlet Drive [mm]	Dimensions [mm]			Weight [kg]
	cN·m		kgf·cm		ozf·in		lbf·in			Overall Length	Width	Height	
	Min.-Max.	1digit	Min.-Max.	1digit	Min.-Max.	1digit	Min.-Max.	1digit					
TDT600CN3-G	2-60	0.005	0.2-6	0.0005	3-80	0.005	0.2-5	0.0005	6.35 Hex (Male)	230	220	225	11
TDT600CN3-G	20-600	0.05	2-60	0.005	30-800	0.05	2-50	0.005	with a groove (0.7mm)				

Note
1. Loading device keeps stable measuring conditions to avoid reading errors.
2. Max 1,000 measured data can be stored.

Standard Accessories
1. AC Adapter/BA-6, 2. Loading Device/STA

■ TDT3-G Optional Accessories

Connecting Cable (P.47)

Part #	Applicable Models
383	TDT3-G → PC, EPP16M3
385	TDT3-G → PC

Battery Pack (P.47)

Model
BP-100-3

Loading Device

Model
TDTLA3
LTA
STA

As for TDTLA3, TDT600CN3-G measures 2-60 cN·m and TDT600CN3-G measures 20-600cN·m range of torque wrenches. LTA is for direct reading torque drivers such as FTD and STC. STA is for tightening torque driver such as RTD and LTD.

Printer (P.67)

Model
EPP16M3

Data Filing System (P.64)

Model	Media
DFS	CD-ROM

Hex Adapter

Part #	Description
480	1/4-5.5-8-12
481	1/4-6-10-13
482	1/4-7-11-14
483	1/4-16-19-22
484	1/4-17-21-24

Loading Device Connecting Adapter

Part #	Description
485	STA, TDTLA3, LTA to TDT, TDT2-G

Excel Receiver Software

The Excel Receiver software allows for the transfer of collected torque data from various Tohnichi digital torque equipment into a Microsoft Excel worksheet. Tohnichi also provides customized software upon request.

Excel Receiver is compatible with the following equipment:

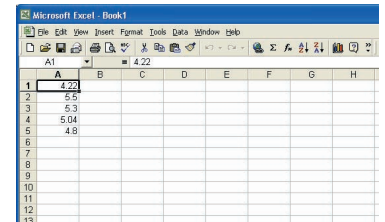

CEM100N3x15D-G

CEM3-G: ExRcv for CEM



CTB100N2x15D-G

CTB2-G: ExRcv for CTB



CPT-G: ExRcv for CPT



TDT600CN3-G

TDT600CN3-G+TDTLA3

TDT3-G: ExRcv for TDT



DOTE100N3-G

DOTE3-G: ExRcv for DOTE



LC200N3-G

LC3-G: ExRcv for LC



ST50N3-3/8-G

ST3-G: ExRcv for ST



ST1000N3-G-BT



ATGE5CN-G



BTGE200CN-G

ATGE-G/BTGE-G: ExRcv for ABTGE



2TME500CN2

TME2: ExRcv for TME



CD5

CD5: ExRcv for CD



STC200CN2-G

STC2-G: ExRcv for STC2-G



ATG/BTG

Analog Torque Gauge

Dial Indicating

3-jaw Chuck

Direct Reading

RoHS

Direction



ATG6CN



BTG36CN

ATG Optional Accessories

Part #	Description
322	Plastic Case and Chuck

- Compact portable handheld design
- Top and side scales for easy reading
- Three fingered keyless chuck

S.I. Model	Torque Range [cN-m]		Metric Model	Torque Range [gf-cm/kgf-cm]		American Model	Torque Range [ozf-in/lbf-in]		Chuck Grip [mm]	Dimensions [mm]		Weight [kg]
	Min.-Max.	Grad.		Min.-Max.	Grad.		Min.-Max.	Grad.		Overall Length	Outside Diameter	
ATG045CN	0.05-0.45	0.01	45ATG	5-45	1	ATG06Z	0.06-0.6	0.01				
ATG09CN-S	0.1-0.9		90ATG-S	10-90	2	ATG1.5Z-S	0.2-1.5	0.02				
ATG1.5CN-S	0.2-1.5	0.02	150ATG-S	20-150		ATG2.4Z-S	0.3-2.4	0.05				
ATG3CN-S	0.3-3	0.05	300ATG-S	30-300	5	ATG4.5Z-S	0.5-4.5	0.1				
ATG6CN-S	0.6-6	0.1	600ATG-S	60-600	10	ATG9Z-S	1-9	0.2	φ1-φ6.5	99	43.5	0.18
ATG12CN-S	1-12	0.2	1200ATG-S	100-1200	20	ATG18Z-S	2-18	0.5				
ATG24CN-S	3-24	0.5	2400ATG-S	300-2400	50	ATG36Z-S	4-36	0.5				
-	-	-	-	-	-	BTG60Z-S	6-60	1				
-	-	-	-	-	-	BTG120Z-S	10-120	2				
				kgf-cm	kgf-cm		lbf-in	lbf-in				
BTG15CN-S	2-15	0.2	1.5BTG-S	0.2-1.5	0.02	1.5BTG-A-S	0.1-1.5	0.02	φ1-φ8.5	135	64.2	0.52
BTG24CN-S	3-24		2.4BTG-S	0.3-2.4	0.05	2.4BTG-A-S	0.3-2.4	0.02				
BTG36CN-S	4-36		3.6BTG-S	0.4-3.6		0.1	3.6BTG-A-S	0.4-3.6	0.05			
BTG60CN-S	6-60	1	6BTG-S	0.6-6	0.1	6BTG-A-S	0.6-6	0.1				
BTG90CN-S	10-90		9BTG-S	1-9		9BTG-A-S	1-9	0.1				
BTG150CN-S	20-150	2	15BTG-S	2-15	0.2	15BTG-A-S	2-15	0.2				

- Note
1. ATG045CN, 45ATG and ATG06Z are provided without side or top memory pointer.
 2. "Without memory pointer" models are available. Remove "-S" from the model name when ordering. (Ex. ATG09CN, BTG15CN)
 3. Aluminum case and steel chuck are standard for ATG models. Plastic case and chuck can be ordered separately.

ATGE-G

Digital Torque Gauge

Digital

3-jaw Chuck

Direct Reading

Battery

RoHS

Direction



ATGE5CN-G



- Digital torque gauge with pull out display
- For measurement, inspection and tightening of low torque range
- 3 way configuration; hand-held, table top or as a torque meter with testing fixture

Model	Torque Range								Chuck Grip [mm]	Dimensions [mm]		Weight [kg]
	[cN-m]		[mN-m]		[gf-cm]		[ozf-in]			Overall Length	Outside Diameter	
	Min.-Max.	1 digit	Min.-Max.	1 digit	Min.-Max.	1 digit	Min.-Max.	1 digit				
ATGE05CN-G	0.1-0.5	0.001	1-5	0.01	10-50	0.1	0.15-0.7	0.001	φ1-6.5	120	67	0.305
ATGE1CN-G	0.2-1	0.001	2-10	0.01	20-100	0.1	0.3-1.4	0.001				
ATGE2CN-G	0.4-2	0.002	4-20	0.02	40-200	0.2	0.6-2.8	0.002				
ATGE5CN-G	1-5	0.005	10-50	0.05	100-500	0.5	1.5-7	0.005				
ATGE10CN-G	2-10	0.01	20-100	0.1	200-1000	1	3-14	0.01				
ATGE20CN-G	4-20	0.02	40-200	0.2	400-2000	2	6-28	0.02				

- Note
- Aluminum case and steel chuck are standard for ATGE-G models. Plastic case and chuck/322 (page 59) is sold separately.

Standard Accessories Coin-type lithium battery (built-in the body), Carrying case

ATGE-G Common Specifications

Direction	CW/CCW
Display	7 segment LCD display, Counter 3 digits (character height 3mm), Torque value: 4 digits (character height 7mm) Torque unit, Battery indicator, Direction
Mode	PEAK/RUN
Data Memory	999 readings
Statistic Processing	Sample size, Max. value, Min. value, Mean value
Data Output	USB output (USB mini B connector)
Power	Coin-type lithium battery (CR2450)
Continuous in Use	Approx. 10 hours when using coin battery
Other Functions	Auto power off (3 min.), Auto memory reset (0.5-5) seconds variable, Auto zero adjustment, Residual battery indicator (4 steps), Buzzer ON/OFF, Unit Conversion
Operating Temperature	0 to 40°C non condensing
Standard Options	Coin battery (built in), Carrying case

◆ Calibration Kit for ATG/BTG/ATGE-G/BTGE-G



* Sold separately. Refer to page 62.

BTGE-G

Digital Torque Gauge

Direction



BTGE200CN-G

- Digital
- 3-jaw Chuck
- Direct Reading
- Battery
- RoHS

- Multiple units of measure through keypad setup
- For measurement, inspection and tightening of low torque ranges
- Flip-up display can be adjusted for optimal reading

Accuracy ±2%+1digit

Model	Torque Range								Chuck Grip [mm]	Dimensions [mm]		Weight [kg]
	[cN·m]		[kgf·cm]		[ozf·in]		[lbf·in]			Overall Length	Outside Diameter	
	Min.-Max.	1 digit	Min.-Max.	1 digit	Min.-Max.	1 digit	Min.-Max.	1 digit				
BTGE10CN-G	2-10	0.01	0.2-1	0.001	3-14	0.01	0.2-0.88	0.001	φ1-φ8.5	130	75	0.65
BTGE20CN-G	4-20	0.02	0.4-2	0.002	6-28	0.02	0.4-1.7	0.002				
BTGE50CN-G	10-50	0.05	1-5	0.005	15-70	0.05	1-4.4	0.005				
BTGE100CN-G	20-100	0.1	2-10	0.01	30-140	0.1	2-8.8	0.01				
BTGE200CN-G	40-200	0.2	4-20	0.02	60-280	0.2	4-17	0.02				

- Note**
1. Can be used for checking accuracy of torque screwdrivers.
 2. Max 999 readings can be saved with statistical function max/min/mean values.

BTGE-G Optional Accessories

Connecting Cable (P.47)

Part #	Applicable Models
384	BTGE-G (USB mini B) → PC (USB A)

Measurement Board

Model
809

BP-C1



Battery Pack

Model
BP-C1

ATG/BTG/ATGE-G/BTGE-G Optional Accessories



No.808

ATGE-G/BTGE-G Measurement stand

To firmly fix ATGE-G/BTGE-G to use as table top configuration

Part #	Applicable Models
808	ATGE-G
809	BTGE-G



No.800

Table attachment

4 poles are designed to clamp objects of any shape (Chucking diameter φ10-φ58)

Part #	Applicable Models
800	ATGE-G/BTGE-G



No.806

Calibration adapter for ATGE-G/BTGE-G

Adapter for calibration devices (ATGTCL/BTGTCL) to mount on ATGE-G/BTGE-G

Part #	Applicable Models
806	ATGE-G
807	BTGE-G



BA-5

Adapter for USB connector

External power supply adapter for ATGE-G/BTGE-G with using USB connecting cable.

Part #	Applicable Models
BA-5	ATGE-G/BTGE-G



No.384

USB connecting cable

Cable for external USB data output or connecting BA-5

Part #	Applicable Models
384	ATGE-G/BTGE-G



No.322

Plastic chuck

Plastic chuck for fragile objects

Part #	Applicable Models
322	ATG/ATGE-G



BP-C1

Battery pack

Part #	Applicable Models
BP-C1	BTGE-G



ATGE-G with table attachment and measurement stand



BTGE-G with table attachment and measurement stand



TCF

Fixed Type Torque Sensor

Voltage Output Fixed RoHS

- Requires CD5 to display torque reading



CD5



TCF20N

Display (Sold separately)

S.I. Model	Torque Range [N·m]	Metric Model	Torque Range [kgf·cm]	American Model	Torque Range [lbf·in/lbf·ft]	Inlet Drive [mm]	Dimensions		Weight [kg]
	Min.-Max.		Min.-Max.		Min.-Max.		Height [mm]	Diameter [mm]	
TCF02N	0.02-0.2	TCF1.8	0.18-1.8	TCF1.8I	lbf·in	6.35	56	45	0.45
TCF04N	0.04-0.4				0.18-1.8				
TCF1N	0.1-1	TCF18	1.8-18	TCF18I	0.9-9.0	9.5	66	70	0.6
TCF2N	0.2-2				1.8-18				
TCF4N	0.4-4	TCF180	18-180	TCF180I	3.5-35	12.7	100	105	2.5
TCF10N	1-10				18-180				
TCF20N	2-20	TCF1800	180-1800	TCF1800I	lbf·ft	19.0	135	140	6
TCF40N	4-40				180-1800				
TCF100N	10-100	TCF18000	1800-18000	TCF18000I	15-150	25.4	180	178	12
TCF200N	20-200				1800-18000				
TCF400N	40-400	TCF18000	1800-18000	TCF18000I	75-750	19.0	135	140	6
TCF1000N	100-1000				1800-18000				
TCF2000N	200-2000	TCF18000	1800-18000	TCF1500F	150-1500	25.4	180	178	12

Note 1. Calibration kits (TCL models) are optional. Refer to page 62.
2. Display (CD5) is sold separately.

Standard Accessories Connecting Cable

Attachment for TCF (Sold separately)

TP (Test Piece): Torque measurement for power torque tools



TP18N+TCF20N

Model	Torque Range			Applicable TCF Model	Inlet		Dimensions		Weight [kg]
	S.I. [N·m]	Metric [kgf·cm]	American [lbf·in/lbf·ft]		Width Across Flats [mm]	Nominal Size of Screw	Diameter [mm]	Height [mm]	
	Min.-Max.	Min.-Max.	Min.-Max.		[mm]				
TP2.5N	0.25-2.5	2.5-25	2-22	TCF02N-TCF4N	8	M4	18	58	0.08
TP18N	1.8-18	18-180	16-160	TCF10N, TCF20N	13	M6	35	83.5	0.27
TP180N	18-180	180-1800	30-130	TCF40N-TCF200N	24		65	148	1.9
TP1800N	180-1800	1800-18000	130-1300	TCF400N-TCF2000N	50		140	297.5	16.8

Note 1. Adapter 4H-3 (#273) is necessary for TCF40N.
2. Adapter 8P-6 (#295) is necessary for TCF400N.



DTF5-2+TCF20N

DTF (Drill Chuck): Torque measurement for axial work pieces

Model	Applicable TCF Models	Chuck Size [mm]	Square Drive [mm]	Dimensions	
				Diameter [mm]	Height [mm]
DTF5-3	TCF02N-TCF4N	Max. φ5	6.35	33	65
DTF5-2	TCF10N-TCF40N		9.5		61



TTF11+ATF18+TCF20N

TTF/ATF: Table/Fixture: Ideal for testing torque on bottle caps

Model	Applicable TCF	Chuck Size [mm]	Table Dia. [mm]
TTF	ATF		
TTF7	ATF1.8-2	φ10-70	φ70
TTF11	ATF18	φ14-110	φ110
TTF19	ATF1.8-2	φ18-190	φ180
	ATF18		

Note ATF attachment is required to fix TTF table.

TCR

Rotary Type Torque Sensor

Voltage Output Rotary RoHS

- Captures directly applied torque
- Requires CD5 to display torque reading



CD5



TCR18N

Display (Sold separately)

S.I. Model	Torque Range [N·m]	Metric Model	Torque Range [kgf·cm]	American Model	Torque Range [lbf·in/lbf·ft]	Allowable Rotation [r.p.m]	Square Drive [mm]	Height [mm]	Width [mm]	Weight [kg]
	Min.-Max.		Min.-Max.		Min.-Max.					
TCR18N	1.8-18	TCR180	18-180	TCR180-A	lbf·in	2000	9.5	91	76	0.9
TCR180N	18-180				18-180					
TCR700N	70-700	TCR18000	1800-18000	TCR18000-A	lbf·ft	1000	19.0	118.5	95	2.0
TCR1800N	180-1800				1800-18000					

Note 1. Calibration kits (TCL models) are optional. Refer to page 62.
2. Display (CD5) is sold separately.

Standard Accessories Connecting Cable

◆ Calibration Kit for TCF/TCR



* Sold separately. Refer to page 62.



Calibration Kit

◆ Calibration Kit for DOTE3-G/DOT RoHS

Model	Description				
	Calibration Lever	Stand	Reaction Unit	Scale Holder	Applicable Models
DOTCL36N	KL-DOTCL36N	KS-DOTCL	RU-DOTCL100N	WT0.5	DOT35N
DOTCL100N	KL-DOTCL100N				DOT50N
DOTCL200N	KL-DOTCL200N				DOT20N3-G
DOTCL360N	KL-DOTCL360N		RU-DOTCL360N	WT1	DOT50N3-G
DOTCL700N	KL-DOTCL700N				DOT100N
DOTCL1000N	KL-DOTCL1000N				DOT100N3-G
		RU-DOTCL700N	WT5	DOT200N3-G	
				DOT300N	
				DOT500N3-G	
				DOT700N	
				DOT1000N3-G	

◆ Calibration Kit for TF RoHS

Model	Description				Applicable Models
	Calibration Lever, Adapter	Stand	Wire		
TFTCL200N	Lever × 2	1 Set	Wire × 4		TF200N
TFTCL500N	Adapter × 2			TF500N	
TFTCL1000N	Lever × 3			TF1000N	
TFTCL2000N	Adapter × 2		Wire × 6		TF2000N
TFTCL3000N	Lever × 3			TF3000N	
	Adapter × 1				

Note Supplied upon request.

◆ Calibration Kit for TCC2-G RoHS

Model	Description				Optional Item	Applicable Models
	Calibration Lever	Stand	Wire	Scale Holder		
TCCTCL100N2			Wire × 2	100g × 1,	1kg × 1, 2kg × 2,	TCC100N2-G
TCCTCL100N2-D			Wire × 3	1kg × 1	5kg × 3, Weight Set	TCC100N2-D-G
TCCTCL500N2	Lever × 2	1 Set	Wire × 4	500g × 1 1kg × 1	1kg × 1, 2kg × 2, 5kg × 9, Weight Set	TCC500N2-G
TCCTCL1000N2			Wire × 2	1kg × 1 5kg × 1	1kg × 1, 2kg × 2, 5kg × 13, Weight Set	TCC1000N2-G

Note Contact Tohnichi in case you have DOTCL.

◆ Calibration Kit for TDT3-G RoHS

Model	Description	Applicable Models
TDTCL60CN	Calibration Lever × 1, Wire × 1, Calibration Roller × 1, Scale Pan (100g) × 1, Scale Holder (1kg) × 1,	TDT60CN3-G
TDTCL600CN	Calibration Lever × 1, Wire × 1, Calibration Roller × 1, Scale Pan (100g) × 1, Scale Holder (1kg) × 1,	TDT600CN3-G

RoHS

◆ Calibration Kit for ATG/BTG/ATGE-G/BTGE-G

Model	Description	Applicable Models
ATGTCL24CN	Main Unit, Calibration Pulley × 2, Wire × 2, Scale Pan (5g, 100g)	ATG/ATGE-G
BTGTCL150CN	Main Unit, Calibration Pulley × 2, Wire × 3, Scale Pan (5g, 100g)	BTG/BTGE-G

Note Adapter (#807) is required when calibrating BTGE models.

◆ Calibration Kit for TME2/TM RoHS

Model	Description	Applicable Models
2TMTCL	Wire × 1, Roller × 1, Frame × 1, Bolt × 2, Scale Holder (1kg) × 1, Scale Pan (100g) × 1	2TM/2TME2
3TMTCL	Wire × 1, Roller × 1, Frame × 1, Bolt × 2, Scale Pan (5g × 1, 100g × 1)	3TM/4TM/3TME2

◆ Calibration Kit for LC3-G/ST3-G/TCF/TCR RoHS

Model	Description	Applicable Models
TCL50N	Calibration Lever, Wire, Scale Holder (1kg), Scale Pan (100g)	TCF10N-TCF40N, TCR18N LC20N3-G, ST10N3-G-ST50N3-1/2-G
TCL200N	Calibration Lever, Wire, Scale Holder (1kg)	TCF100N-TCF200N, TCR180N LC200N3-G, ST100N3-G-ST200N3-G
TCL800N	Calibration Lever, Wire, Scale Holder (10kg)	TCF400N, TCR700N, ST500N3-G
TCL1000N	Calibration Lever, Wire, Scale Holder (5kg)	TCF1000N, ST1000N3-G, LC1000N3-G
TCL2000N	Calibration Lever, Wire, Scale Holder (10kg)	TCF2000N, TCR1800N, LC1400N3-G

Note 1. TCL1000N and TCL2000N are supplied upon request.
2. #271 is required when calibrating ST10N2.



DOTCL100N



TFTCL2000N



TDTCL600CN



ATGTCL24CN



2TMTCL

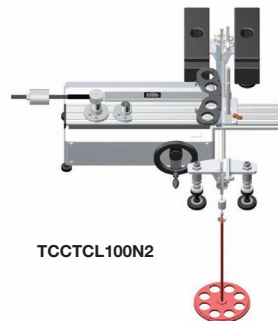

TCCTCL100N2

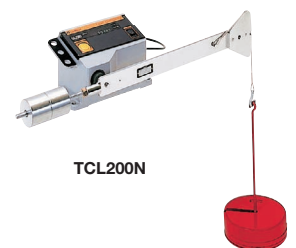

TCL200N

◆ Weight RoHS

Model	Weight
WP-TCL5	5kg
WP-TCL2	2kg
WP-TCL1	1kg
WS-TCL2	Weight Set (2kg)

Note 1. A dead weight is available for sale.
2. Calibration certificate for dead weight is available on request, charged option.

BTM/ B-BTM

Bolt Tension Meter

Dial Indicating **Hydraulic** **Bourdon Type**

- Bourdon type hydraulic bolt tension meter
- Measure bolt tension to determine optimal torque

Accuracy ±3%



BTM400K



B-BTM13K

S.I. Model	Axial Tension Range [kN]		Metric Model	Axial Tension Range [ton]		American Model	Axial Tension Range [lbf]		Applicable Nominal Diameter of Bolts (Minimum Length) [mm]	Dimensions			Weight [kg]
	Min.-Max.	Grad.		Min.-Max.	Grad.		Min.-Max.	Grad.		Overall Length [mm]	Overall Thickness [mm]	Overall Height [mm]	
BTM400K	100-400	5	40BTM-2	10-40	0.5	40BTM-2-A	23000-90000	1000	Hexagon Bolt M16 (70), M20 (75) M22 (80), M24 (85) Torsia Bolt M16 (65), M20 (70) M22 (75), M24 (80)	260	64	280	12.6
B-BTM13K	1.2-13	0.2	1.3B-BTM	0.12-1.3	0.02	1.3B-BTM-A	300-2800	50	Standard Bolt M5 (20), M6 (21) M7 (22), M8 (23)	106	78	217	7.7
B-BTM40K	4-40	0.5	4B-BTM	0.4-4	0.05	4B-BTM-A	1000-9000	100	Standard Bolt M10 (29), M12 (31) M14 (32)	134	82	241	9.8
B-BTM130K	12-130	2	13B-BTM	1.2-13	0.2	13B-BTM-A	3000-28000	500	Standard Bolt M16 (41), M18 (43) M20 (44), M24 (47)	186	106	287	17.5
B-BTM400K	40-400	5	40B-BTM	4-40	0.5	40B-BTM-A	1000-90000	1000	Standard Bolt M27 (72), M30 (74) M36 (79), M42 (84)	280	126	369	31.0

Note
 1. BTM400K comes with a plate and bushing for torsia bolt M20 and M22. Other plates and bushings are optional.
 2. "Hexagon Bolt" in the above list stands for the high-tensile hexagon bolt for friction bonding.

Standard Accessories Plate, Bushing, Spanner for plate, Bolt for plate, Storage Case, Calibration Certificate

BTM Optional Accessories

Bushing for Hexagon Bolt

Part #	Applicable Nominal Diameter of Bolts
650	M16
651	M20
652	M22
653	M24

Bushing for Torsia Bolt

Part #	Applicable Nominal Diameter of Bolts
665	M16
666	M20
667	M22
668	M24

Plate for Torsia Bolt/Hexagon Bolt

Part #	Applicable Nominal Diameter of Bolts
669	M16
670	M20
671	M22
672	M24

Fcon Bolt Tension Stabilization

RoHS

- Creates consistent bolt tension
- Applied to fasteners and nuts
- Acquisition of patent in EU.



Fcon

Model
Fcon

Sales Unit: 10pcs/case
Content: 90g/bottle

How to apply Fcon on the bolt (in case of M10 bolt)
 Follow the illustration below. Apply some along the screw thread (2 mm width more or less), and on the bearing surface at 3 different spots evenly. Use appropriate amount depending on the size of the bolt.

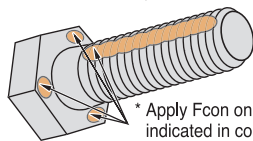

* Apply Fcon on part indicated in color.

Axial Tension Stability Characteristics

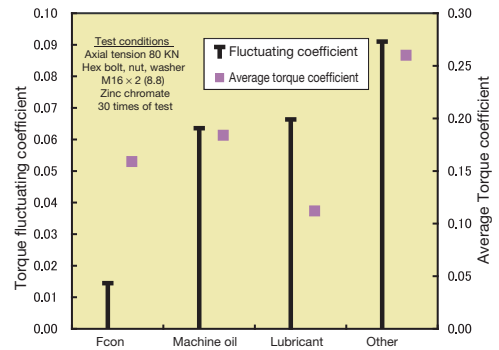

Characteristic of axial tension stabilization

Torque coefficient calculated by formula $K = t/(d \times f)$
 T = tightening torque, d = nominal size of screw, F = axial tension

Torque fluctuating coefficient = torque coefficient standard deviation/average torque coefficient

Influence of Tightening Speed

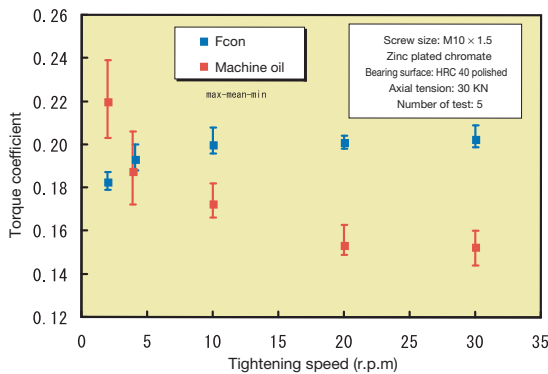

Influence of tightening speed on torque coefficient

Influence of Temperature

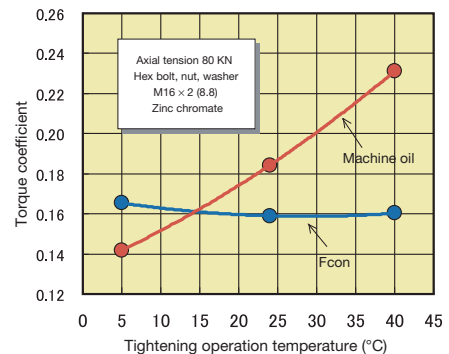

Influence of temperature on torque coefficient

TT2000

Ultrasonic Tension Meter



TT2000

Digital **Direct Reading**

- Non-destructive axial bolt tension tester
- Input information regarding fastener & materials
- Sound wave lengths are measured and compared.

Model
TT2000
TT2000C
TT2000M

TT2000 Specifications

Measuring Range	5-10,000mm (Steel material)
Applicable Length of Bolt	50-9,000mm
Applicable Nominal Diameter of Bolt	φ6mm dia or more (Applicable for less than φ6mm dia. with an optional sensor)
Ultrasonic Wave Frequency	0.5-15 MHz
Time Axis Resolution	5ns
Result of Measurement	Bolt initial length (mm), Stress (Mpa), Elongation (mm), Propagation rate (μs)
Measuring Resolution	Depends on bolt diameter and length [Ex.] Based on the first echo measurement (steel material) Bolt diameter φ10, Bolt tightening length 50mm ±approx. 1.47kN Bolt diameter φ20, Bolt tightening length 100mm ± approx. 2.94kN
Memory Capacity of Data	2,000pcs. or time pass measurement 300 items (Max. 50 kinds of different bolts can be registered)
Bolt Temperature Correction	Manual input by key, Auto temperature input *1
Display	Color TFT6.4 type (640 × 480dots)
External Output	8 bits serial interface (RS232C) *2 Composite output (NTSC), Alarm output (photo coupler), Encoder input *3
Power Supply	AC85-130V, AC185-265V (50/60Hz) or DC12V *4
Optional Battery	Portable: 2.5h use for 1.5h Charge Built-in case: 8h use for 4.5h charge
Temperature of Use	0-45 Celsius
Dimensions	Body: H160 × W246 × D60mm Body + Built-in battery: H160 × W246 × D246mm
Weight	Body: 1.2kg Body + built-in battery: 4.9kg

Note

1. Optional thermometer can be connected to TT2000C and TT2000M for auto temperature adjustment. Input temperature range is from -40°C to 200°C. Measurement over 60°C requires a sensor specially designed for high temperature.
2. RS232C connector is available only with TT2000C and TT2000M.
3. Composite output, alarm output and encoder input are available only when using a multi connector box (TT2000M) or optional built-in battery case.
4. DC12V can be used only when using the optional portable battery or the built-in battery case.
5. Certificate of calibration is available on request, charged option.

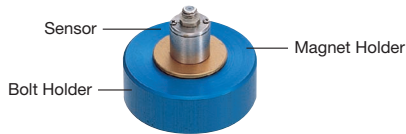

Axial Tension Calibrator

Model
AFC-20G

TT2000 Optional Accessories

Model Name
RS232C Junction Cable A
Portable Battery Cable
RS232C Junction Cable B
Battery Built-in Body
Handy Type Cover
Portable Type Cover
TT2000 Carrying Case
Portable Battery Pack
Light Shielding Hood
Carrying Case for Body with Battery Built-in Body

Ultrasonic Sensor

Part #	Name	Applicable Bolts
606	5C4.8N	More than M6, L1<approx.80mm
607	5C6.4N	More than M8, L1<approx.50cm
608	5C12.7N	More than M14, L1<approx.2m
609	5C19.1N	More than M20, L1<approx.4m

Note

1. L1 is standard bolt length with material in SCM, S-C, SS for ultrasonic wave reflection measurement n=1.
2. Ultrasonic wave sensor is consisting of 3 parts, Sensor, Magnet Holder and Bolt Holder.
3. Standard 5C6.4N does not include bolt holder.
4. 5C6.4N=[5: Frequency (MHZ)]
[C: Oscillator Material (C: piezoelectric ceramics)]
[6.4: Oscillator Diameter, mm]
[N: Perpendicular (Normal)]

Features of ultrasonic wave sensor

1. The magnetic holder provides stabilized force through the sensor, which provides high repeatability measurement.
2. The bolt holder gives same position of the sensor to support more accurate measurement.



FP Force Pen



CD5

Display (Sold separately)

Voltage Output Pen

- Pen style force sensor
- Compact, lightweight, user friendly operation
- Requires CD5 Compact Display

Model	Measurement Range	Rated Output	Accuracy	Allowable Overload	Display (Option)	Weight [g]
	[N]					
FP1	±0.1-1	1mV/V	±1% F.S.	150%	CD42	80
FP2	±0.2-2					
FP4	±0.4-4					
FP10	±1-10					
FP20	±2-20					
FP40	±4-40					

Note 1. Display (CD5) is optional.
2. FP models are supplied upon request.

Standard Accessories Standard Attachment

FG Force Grip



FG100



CD5

Display (Sold separately)

Voltage Output Grip

- Grip style force sensor
- For large product testing
- Requires CD5 Compact Display

Model	Measurement Range	Rated Output	Accuracy	Allowable Overload	Display (Option)	Weight [g]
	[N]					
FG40	±4-40	2mV/V	±1% F.S.	150%	CD42	580
FG100	±10-100					
FG200	±20-200					
FG400	±40-400					

Note 1. Display (CD5) is optional.
2. FG models are supplied upon request.

Standard Accessories Standard Attachment



CD5

Compact Display



CD5



- Digital**
- Sensor Contacts**
- Direct Reading**
- Comparator**
- Judgment**

- Digital display for Tohnichi's torque sensor (strain gauge) products
- Adapted the Black Mask LCD making 3 different colored displays
- OK or NG judgment capability with upper or lower limit setting function

Model
CD5

CD5 Optional Accessories

Printer	
Model	
EPP16M3	

Data Filing System	
Model	Media
DFS	CD-ROM

Connecting Cable (P.47)	
Part #	Applicable Models
383	CD5 → PC, EPP16M3 (D-SUB 9 Pin Female)

CD5 Specifications

Display	Negative type liquid crystal
Resolution	±1/5000 (±1.0 to ±3.0mV/V) ±1/2000 (±0.5 to ±1.0mV/V) 1/2000 (+0.1 to +3.0mV/V)
Input Voltage	±3.0mV/V
Accuracy	Nonlinearity ±0.05% F.S. Zero point drift ±0.1μV/°C (TYP.) Gain drift ±0.01%/°C (TYP.)
Calibration Methods	Equivalent input calibration Calibration by actual weight Calibration using sensor-equipped torque wrench
Data Memory	1000 readings
External Input	RESET/COMP/CLEAR/CHSW
Communication	RS232C compliant, Analog output, HI, OK, LO relay output
Power	AC100-240V±10%
Temperature in Use	0 to 40 no condensation
Dimension	150W × 190D × 94H
Weight	Approx. 1.8 kg

R-DT999

Data Tank



R-DT999

- Auxiliary**
- Infrared Input**
- RS232C Data Output**

- Infrared data collector for torque equipment
- 999 data storage
- External keypad setup functions

Model
R-DT999

R-DT999 Optional Accessories

Printer	
Model	
EPP16M3	

Data Filing System	
Model	Media
DFS	CD-ROM

Connecting Cable (P.47)		
Part #	Applicable Models	Plug
575	R-DT999 → PC, EPP16M3	D-SUB 9 Pin Female
584	R-DT999 → PC	USB A Type

Note Contact Tohnichi for other types of connector shapes.

R-DT999 Specifications

Data Input	Infrared data input (Tohnichi format only)
Display	6 digits, 14segments LCD 4 digits, 7segments LCD 4 digits, 7segments LED
Applicable Models	CEM3-G, CEM2, ST, ST2, STC, CTA, CTB
Data Output	RS232C compliance, USB connector serial output (*USB 1.1)
Power	DC5V 2A
Dimensions	W80 × D125 × H32mm
Standard Accessories	AC adapter (100-240V±10%)
Operating Temperature Range	0-40 Celsius
Weight	205g (body only)

DFS

Data Filing System (CD-ROM)

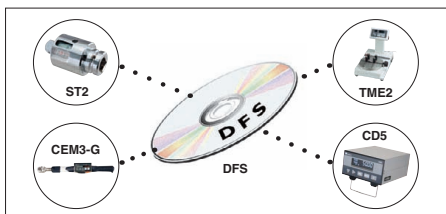

Maximum value, minimum value, data range, mean value, standard deviation and Cp value are calculated to make a histogram on the display.

- Auxiliary**
- CD**

- Data processing software
- Statistics, Standard deviation, Cp values, Charts

Model	Media
DFS	CD-ROM

Connecting Cable to PC (P.47)		
Part #	Applicable Models	Plug
575	CEM3-G, CTA2, CTB2-G, R-DT999 → PC, EPP16M3	D-SUB 9 Pin Female
584	CEM3-G, CTA2, CTB2-G, R-DT999 → PC	USB A Type
383	DOT3-G, LC3-G, TME2, TDT3-G → PC, EPP16M3	D-SUB 9 Pin Female
384	ST3-G, ATGE-G, BTGE-G → PC	USB A Type

Note Contact Tohnichi for other types of connector shapes.

EPP16M3 Printer



EPP16M3

Auxiliary RS232C Data Input

- Printer for digital torque equipment
- Terminal Line Dot printing

Model
EPP16M3

EPP16M3 Optional Accessories

Roll Paper

Part #	Description
1408	Roll Paper

EPP16M3 Specifications

Printed Method	Thermal Line Dot
Total Dot	384 dots
Dots per inch	203 dpi (8dot/mm)
Printing Capacity	32
Number of Dots for Character	12 × 24
Character Size [mm]	1.5 × 3.0
Paper Width/Print Span [mm]	58 / 48
Thermal Paper Outer Diameter [mm]	φ50
Max Printing Speed [mm/sec]	80
Power AC [V]	100 - 240V ± 10% 50/60Hz
Temperature [°C]	0 - 40
Humidity [%RH]	Under 85 (No condensation)
Weight [kg]	Approx. 0.27

Connecting Cable

Part #	Applicable Models	Plug
383	DOT3-G (P.54), LC3-G (P.56), TDT3-G (P.57), TME2 (P.60), CD5 (P.66)	D-SUB 9 Pin Female
575	CEM3-G/CEM3-P (P.36), CTA2 (P.24), R-DT999 (P.66), CTB2-G (P.37)	

DECA 10:1 Ratio Torque Multiplier



DECA900N

Body + Universal Arm

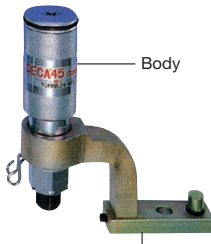

Universal Arm

Auxiliary Straight Rotary RoHS

- Multiplied torque output increases by 10 times
- Ideal for applying high torque values with less force

Model	Output Torque			Torque Ratio	Dimension [mm]			Input Sq. Drive	Weight [kg]	Applicable Universal Arm
	[N-m]	[kgf-m]	[lbf-ft]		Overall Length	Dia.	Output Sq. Drive			
	Min.-Max.	Min.-Max.	Min.-Max.							
DECA450N	90-450	9-45	65-325	10:1	195	52	19.0	9.5	2	UA450N
DECA900N	180-900	18-90	130-650		541	63			3.4	UA900N
DECA1800N	360-1800	36-180	260-1300		270	78	25.4	12.7	5.7	UA1800N
DECA3000N	600-3000	60-300	434-2170		324	95	31.75	19.0	10	UA3000N
DECA4500N	900-4500	90-450	650-3250		367	110	38.1		12.5	UA4500N
DECA9000N	1800-9000	180-900	1300-6500		464	140	50.8		34	UA9000N
DECA18000N	3600-18000	360-1800	2600-13000		540	172	63.5	25.4	60	UA18000N

Accuracy ±5%

- Note
1. Universal Arm is optional.
 2. DECA9000N and DECA18000N are supplied upon request.

- Standard Accessories
1. Metal Case (for DECA450N-DECA900N only)
 2. Portable Handle (for DECA4500N-DECA9000N only)
 3. Metal Case Caster (for DECA18000N only)

AP/DAP Optional Accessories



SA

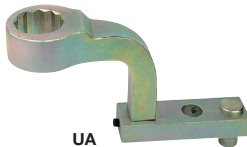

UA

SA Shell Arm Light weight reaction arm

RoHS

Model	Standard Socket Length [mm]	Max. Torque [N-m]
SA400N	50	400
SA700N	62	700
SA1200N	62	1200

UA Universal Arm Heavy duty reaction arm

RoHS

Model	Max. Torque [N-m]	Weight [kg]
UA450N	450	1.2
UA900N	900	2.6
UA1800N	1800	4
UA3000N	3000	7.2
UA4500N	4500	10.9
UA9000N	9000	18
UA18000N	18000	-

Adapter for Torque Wrench Tester



Down Adapter



Ratchet Adapter

DA Down Adapter for Torque Wrench Testers

RoHS

- Compact adapter to reduce the size of square drive

Model	Part #	Dimensions [mm]			Capacity [N-m]	Weight [g]	
		Square Drive (Male)	Square Drive (Female)	Height			
DA3-2	296	9.5	6.35	12	13	14	5
DA4-3	297	12.7	9.5	15	18	70	11
DA6-4	298	19.0	12.7	19	28	220	34
DA8-6	299	25.4	19.0	26	35	750	66
DA12-8	300	38.1	25.4	44	55	2100	320

RA2 Ratchet Adapter for Torque Wrench Testers

RoHS

- Rotates wrench to proper testing position on tester (Gear action 3.75 degrees)

Model	Dimensions [mm]			Capacity [N-m]	Weight [kg]
	Sq. Drive (Male)	Sq. Drive (Female)	Height		
RA3mk2	9.5	9.5	37.3	70	0.28
RA4mk2	12.7	12.7	52.5	220	0.6
RA6mk2	19	19	69.3	850	2.3
RA8mk2	25.4	25.4	92.8	2100	6.3
RA12	38.1	38.1	111	3000	12.6

EVERTORQUE

Lubricant for repairing torque products

RoHS



- For repairs of torque wrenches and torque screwdrivers

Model	Part #
EVERTORQUE	830

Evertorque Application List

	Applicable Model	Applicable Part
Click Type Torque Wrench	QL/QLE/CLE/PQL/PCL/YCL	Thrusting; Steel Ball, Scale Piece, Adjusting Screw; Thread
	WQL	Thrusting; Steel Ball, Scale Piece, Adjusting Screw; Thread, Knob, Protector; Joint
	MPQL	Thrusting; Steel Ball, Scale Piece, Adjusting Screw; Thread, Ratchet, Marker Pipe; Joint
Click Type Torque Screwdriver	RTD, RNTD	Main Shaft, Toggle Sheet; Serration
	RTD, LTD, BMLD	Case, Adjusting Piece; Serration
Semi-Automatic Airtork	A/AC	Thrusting; Steel Ball, Scale Piece, Adjusting Screw; Thread
Fully-Automatic Airtork	AP, AS	
Fully-Automatic Electric Nutrunner	DAP	
Multiple Unit	MC, ME, DCME	Reduction Clutch; Clutch



Torque Settings for Torque Screwdrivers

■ LTD, RTD, MLD

Method of setting torque (Adjustable type):

1. Turn the locker of the main unit clockwise to release the lock.
2. Holding the main scale knurling part with the fingers of your right hand, turn the grip with the fingers of your left hand to set the torque value.

* Setting the torque set values:

- (1) Turn the grip to match the top end of the supplemental graduation with the main scale.
- (2) Match the supplemental graduation line with the main scale vertical line (See the figure below).
3. After setting the torque, turn the main unit locker counterclockwise to lock it.

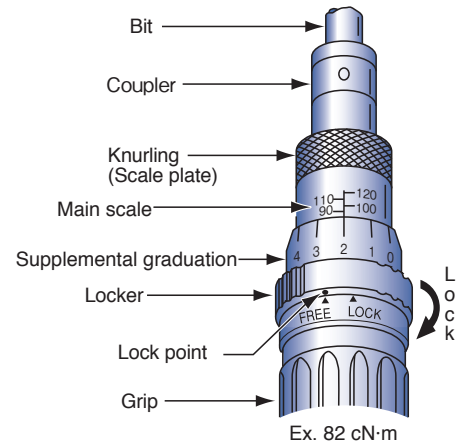

■ NTD, RNTD

Method of setting torque (Preset type):

1. Holding the grip with your left hand, insert the adjusting tool bar into the grooves of the adjustment screw and turn to adjust. Turn clockwise to increase the torque value.
2. Insert with the exclusive bit into the loading device of the Torque Driver Tester (TDT) and fix it.
3. Turn the loading device clockwise to measure the torque value.
4. Continue to repeat procedures 1-3 until the torque is matched.

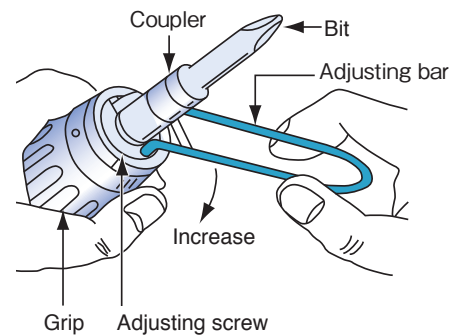

■ FTD50-400CN

Method of preloading the FTD

The preload function is a function that uses the handle to apply a preloading torque close to that of the measuring point to minimize the twisting angle during measurement.

In the FTD series torque screwdrivers, a preload function is provided to prevent your wrist from becoming strained and the torque scale from becoming difficult to read when operating close to the maximum torque.

1. Holding the FTD screwdriver with your left hand, turn the preload handle in the counterclockwise direction using the fingers of your right hand (in case of clockwise measuring).
2. After some slipping turns, the needle will begin to move, and it will be easy to set an optional torque value.
3. If you do not wish to use the preload function, turn the preload handle until there is no tension and the central set indicator (red mark) points to the FREE mark.

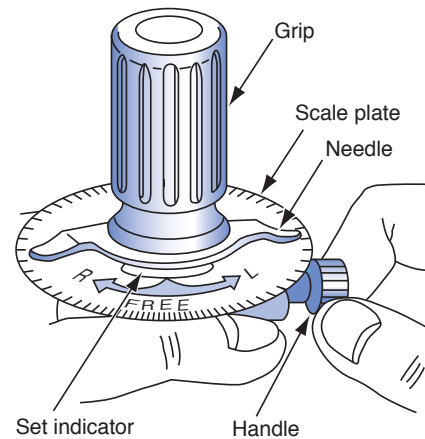

■ FTD-S

Method of setting the FTD-S indicator and memory pointer

1. Make sure the indicator is pointing to zero by matching the scale. If not, adjust to zero by lightly pushing down on the scale and rotating it.
2. Turn the memory pointer in the direction opposite to the measuring direction until it matches the main indicator.
3. Carry out torque measurement or torque tightening.

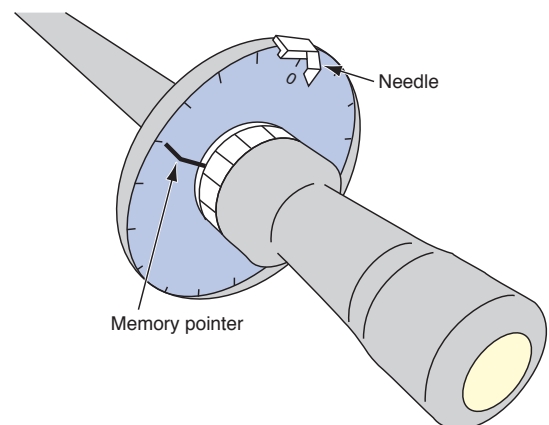

Torque Settings for Torque Wrenches

Adjustable type

● QL, QL5/CL, CL5

1. Turn the adjuster and match up the ▲mark of the adjuster and ▼mark of grip-end cap.
2. Pull the adjuster.
3. Pull the adjuster and turn it to set a torque.

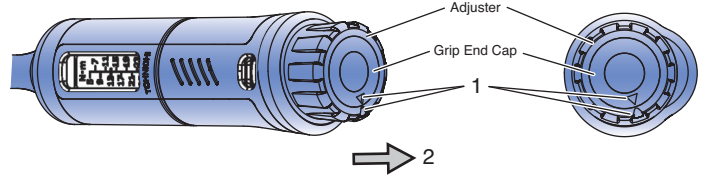

● QL, CL, YCL, A, etc.

1. Release the locker (Turn it counterclockwise).
2. Set the torque by turning the supplemental graduation, confirming the value of the main scale.
3. Turn the locker clockwise to lock it. (Change the locker pin location if the pin is contacted when locking.)

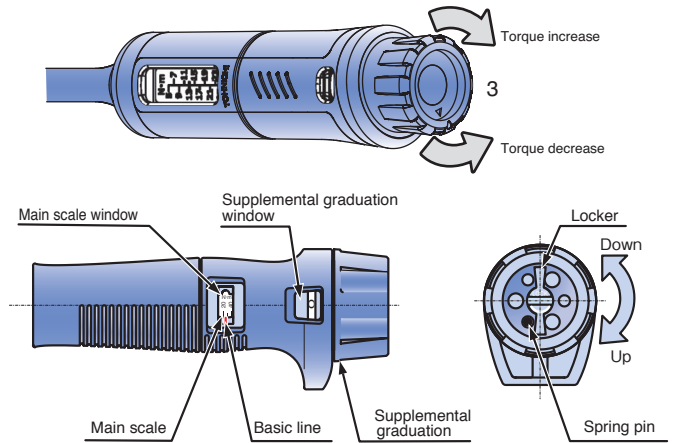

● QLE2, CLE2, DQLE2, and PHLE2

1. Press the push button
2. Remove the extension handle
3. Turning the adjusting handle clockwise to increase the set torque and counterclockwise to reduce it.

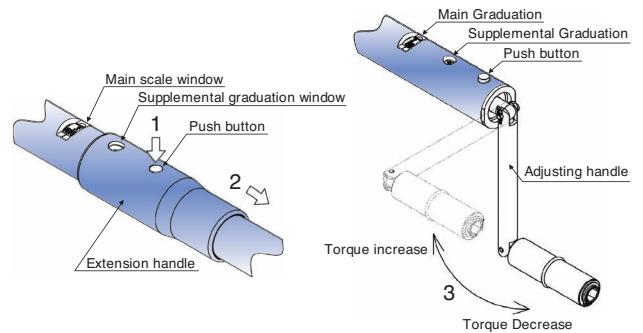

Pre-lock and preset types

● PQL, PCL, AC2, QSP3, etc.

1. Insert the provided hexagon key into the adjusting hexagonal hole.
2. Turn the hexagon key to set the torque, confirming the value on the main scale and supplemental graduation.
3. No locking mechanism is needed for PQL models (An adjusting tool for QSP3 is optional).

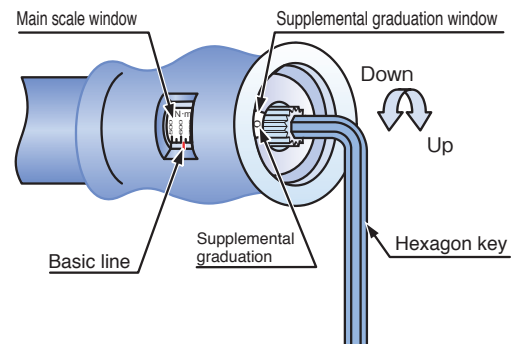

Model	Adjusting hexagon hole mm size across flats
PQL6N4-PQL25N	2.5
PQL50N-200N4	4
AC25N2-100N2	

Dial Indication types

● DB, CDB, T

1. For measurement
The scale on the dial gauge can be rotated. Press the dial case from above and turn the pointer to correctly match "0".
2. Presetting exclusively for tightening
Alternatively, the desired torque can be preset on the dial beforehand and then the bolt can be tightened until the pointer shows "0".

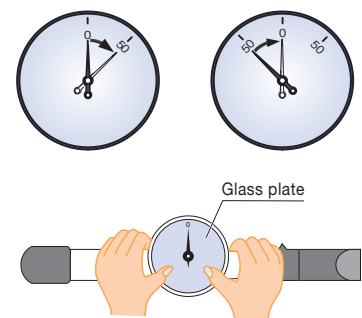

Standard Tightening Torque

Standard tightening torque [N·m] (Reference value)

Nominal diameter	T [N·m]	0.5T series [N·m]	1.8T series [N·m]	2.4T series [N·m]
M1	0.0195	0.0098	0.035	0.047
(M1.1)	0.027	0.0135	0.049	0.065
M1.2	0.037	0.0185	0.066	0.088
(M1.4)	0.058	0.029	0.104	0.140
M1.6	0.086	0.043	0.156	0.206
(M1.8)	0.128	0.064	0.23	0.305
M2	0.176	0.088	0.315	0.42
(M2.2)	0.23	0.116	0.41	0.55
M2.5	0.36	0.18	0.65	0.86
M3	0.63	0.315	1.14	1.50
(M3.5)	1	0.5	1.8	2.40
M4	1.5	0.75	2.7	3.6
(M4.5)	2.15	1.08	3.9	5.2
M5	3	1.5	5.4	7.2
M6	5.2	2.6	9.2	12.2
(M7)	8.4	4.2	15	20.0
M8	12.5	6.2	22	29.5
M10	24.5	12.5	44	59
M12	42	21	76	100
(M14)	68	34	122	166
M16	106	53	190	255
M18	146	73	270	350
M20	204	102	370	490
(M22)	282	140	500	670
M24	360	180	650	860
(M27)	520	260	940	1240
M30	700	350	1260	1700
(M33)	960	480	1750	2300
M36	1240	620	2250	3000
(M39)	1600	800	2900	3800
M42	2000	1000	3600	4800
(M45)	2500	1260	4500	6000
M48	2950	1500	5300	7000
(M52)	3800	1900	6800	9200
M56	4800	2400	8600	11600
(M60)	5900	2950	10600	14000
M64	7200	3600	13000	17500
(M68)	8800	4400	16000	21000

Standard bolt stress: 210 [N/mm²] Stress area of bolt (JIS B 1082)

Standard tightening torque [kgf·cm] (Reference value)

Nominal diameter	T [kgf·cm]	0.5T series [kgf·cm]	1.8T series [kgf·cm]	2.4T series [kgf·cm]
M1	0.199	0.100	0.357	0.479
(M1.1)	0.275	0.138	0.500	0.663
M1.2	0.377	0.189	0.673	0.897
(M1.4)	0.591	0.296	1.06	1.43
M1.6	0.877	0.438	1.59	2.10
(M1.8)	1.31	0.653	2.35	3.11
M2	1.79	0.897	3.21	4.28
(M2.2)	2.35	1.17	4.18	5.61
M2.5	3.67	1.84	6.63	8.77
M3	6.42	3.21	11.6	15.3
(M3.5)	10.2	5.1	18.4	24.5
M4	15.3	7.6	27.5	36.7
(M4.5)	21.9	11.0	39.8	53.0
M5	29.4	14.7	53.0	70.6
M6	53.0	26.5	93.8	124
(M7)	85.7	42.8	153	204
M8	127	63.2	224	301
M10	250	127	449	602
M12	428	214	775	1020
(M14)	693	347	1240	1690
M16	1080	540	1940	2600
M18	1490	744	2750	3570
M20	2080	1040	3770	5000
(M22)	2880	1430	5100	6830
M24	3670	1840	6630	8770
(M27)	5300	2650	9590	12600
M30	7140	3570	12800	17300
(M33)	9790	4890	17800	23500
M36	12600	6320	22900	30600
(M39)	16300	8160	29600	38700
M42	20400	10200	36700	48900
(M45)	25500	12800	45900	61200
M48	30100	15300	54000	71400
(M52)	38700	19400	69300	93800
M56	48900	24500	87700	118000
(M60)	60200	30100	108000	143000
M64	73400	36700	133000	178000
(M68)	89700	44900	163000	214000

Note: Conversion values rolled up to effective 3-digits.

■ Screws and Applicable “T” Series

	Standard T series	0.5T series	1.8T series	2.4T series
Applicable screws (Strengths) (Material)	4.6-6.8 SS, SC, SUS	- Brass, Copper, Aluminum	8.8-12.9 SCr, SNC, SCM	10.9-12.9 SCr, SNC, SCM, SNCM
Axial tension standard value [N/mm ²] Min - Max	210 300-160	105 150-80	380 540-290	500 710-380
Application	To be applied to ordinary screws, unless otherwise specified	Male and female screws with copper, aluminum or plastic, for die-cast plastic products	Durable screw joints made of special steel including those affected by additional dynamic loads (Friction clamping)	
Applicable products	Ordinary products	Electronic products	Vehicles, Engines	Construction products

* The maximum to the minimum of the axial stress is considered as the dispersion of the torque coefficient.
 Example: max = 210 × (0.2/0.14) = 300 [N/mm²]
 Torque coefficient: 0.14 (minimum) - 0.2 (average) - 0.26 (maximum)

■ Calibration Certificate ■

- Torque wrenches are measuring instruments. The calibration certificate is the document which certifies the accuracy of the torque products, which are traceable to Japanese national standards. Please keep the calibration certificate for future use.
- Accuracy % is calculated on each indicated value. Accuracy stated as “+/- a percentage + 1 digit” indicates that digital display will round up to next digit in resolution if value falls between digits.
- Tohnichi’s torque products provided with a calibration certificate can be used immediately at ISO9000 facilities without the need for further acceptance inspection or any additional certifications.
- The calibration certificate is effective for 1 year from the date of first use within 3 years from the date of inspection. Please fill in the date in the calibration certificate when first used.
- Tohnichi’s manual torque tools are normally guaranteed to 100,000 tightening cycles or 1 year. For click type torque wrenches, it can be also used up to 1,000,000 tightening cycles if the function is properly maintained and adjusted at every 100,000 cycles.

■ Restriction of Hazardous Substances Directive (RoHS) ■

Following RoHS, which restricts the use of certain hazardous materials in product manufacturing, Tohnichi has expanded its efforts in environmentally friendly procurement. Starting with our Product Catalog 2011 edition, the **RoHS** mark is shown on all applicable models conforming to the RoHS directive. For details, please contact Tohnichi.



Tohnichi's Worldwide Services System

Torque equipment must have durability, ease-of-use, and even more importantly, high accuracy. To insure high accuracy, torque products should be properly used and maintained throughout the lifetime of the equipment. Tohnichi has created an international service network to provide customers with a variety of after sales services.

1. Tohnichi's International Service Network

As a world leading torque equipment brand, Tohnichi has developed sales and service agents. Our agencies operate in 50 countries or regions through hundreds of dealers supplying products and also repair services to customers around a world.

The screenshot shows the Tohnichi website interface. Three callout boxes are present:

- Top Callout:** "[Registration is required for download services] To First Users" with a "SIGN IN" button.
- Middle Callout:** "Parts List Maintenance for Tohnichi torque products" with a "GO" button.
- Bottom Callout:** "Tohnichi Worldwide Network Find a Tohnichi representative in your area!" with a "Click here" button.

[Tohnichi Web Homepage]
<http://tohnichi.jp/english/index.html>

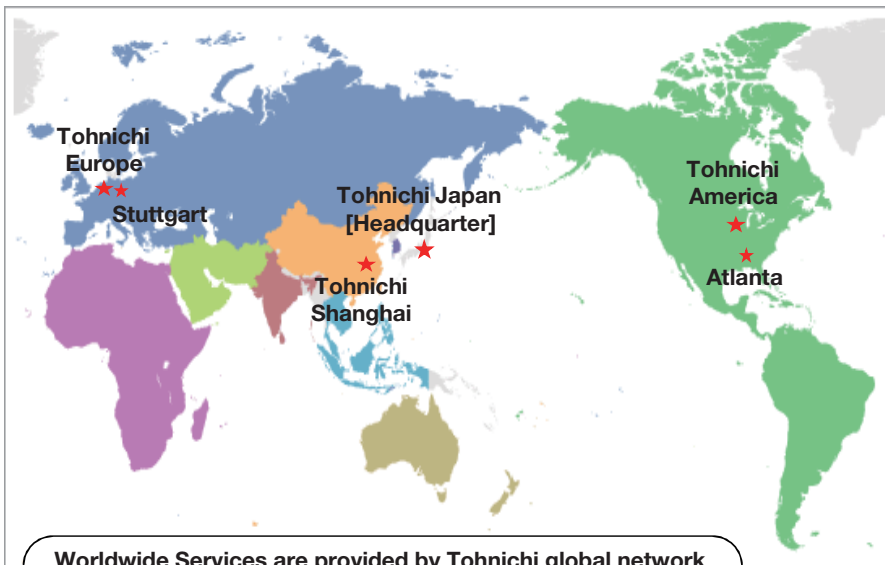

Worldwide Services are provided by Tohnichi global network
 [Tohnichi Japan] Regions of Asia, Oceania, and Middle east
 [Tohnichi Shanghai] China
 [Tohnichi America] Regions of North and South America, Canada
 [Tohnichi Europe] Regions of Europe, Russia, and Africa

2. Tohnichi Web Parts List/Parts Supplies

Detailed parts information is available through Tohnichi's website.
Search by Model or Part name.

View detailed tool diagrams: click and select parts to create a convenient list for parts ordering (Your Parts List).

[Parts List Top Page]

The screenshot shows the 'Parts List Top Page' with the following callouts:

- [Search Parts from Model]**: Enter model name. (Points to the 'Models to Parts' button)
- [Search Model from Parts]**: Enter parts No. (Points to the 'Parts to Models' button)

The page includes a navigation bar with 'TOHNICHI', 'Search', 'Product Categories', 'Models to Parts', 'Parts to Models', and 'Your Parts List'. Below the navigation is a 'Product Categories' list with items like TORQUE WRENCH, TORQUE DRIVER, TORQUE MEASURER, BOLT TENSION MACHINE, MULTI PLIERS, SEMI-AUTOMATIC AIRTORK, UNI TORK, FULL-AUTOMATIC AIRTORK, and MULTIPLE UNIT. A search area contains 'Product Categories', 'Models to Parts', and 'Parts to Models' buttons. Instructions below the buttons describe the search process.

Two screenshots showing search results:

- Models to Parts**: Search for Model Name: ql100n4. Results table:

Parts No.	Classification1	Classification2
QL100N4	TORQUE WRENCH	QL
QL100N4-MH	TORQUE WRENCH	QL-MH
- Parts to Models**: Search for Part No.: 00T16061c. Results table:

Parts No.	Model	Classification1	Classification2
00T16061C	PQL50N	TORQUE WRENCH	PQL
00T16061C	QF60N	TORQUE WRENCH	QF
00T16061C	QL50N	TORQUE WRENCH	QL
00T16061C	QL50N-MH	TORQUE WRENCH	QL-MH
00T16061C	QSP50N3	TORQUE WRENCH	QSP
00T16061C	WQL50N	TORQUE WRENCH	WQL

The screenshot shows the 'Parts List' page for model QL100N4. The page title is 'MODEL QL3'. It features a detailed exploded view diagram of the tool with numbered parts (1-38). Below the diagram is a table with the following data:

Select	No.	Part No.	Unit of Measure Code	Applicable Model	Part Name
Select	1	-	1		
Select	2	01T48017	1		SAW, HEAD
Select	3	01T48013	1		COVER, HEAD
Select	4	01T48020	1		CAM
Select	5	03T04762	1		LEVER, RATCHET
Select	6	01T03405	1		SPRING, RATCHET

[Parts List]



TOHNICHI MFG. CO., LTD.

2-12, Omori-Kita 2-Chome, Ota-Ku, Tokyo 143-0016, Japan

TEL:+81-3-3762-2455 FAX:+81-3-3761-3852

E-mail : overseas@tohnichi.co.jp

URL : <http://tohnichi.jp/english/index.html>

N.V. TOHNICHI EUROPE S.A.

Industrieweg 27, Boortmeerbeek, B-3190 Belgium

TEL:+32 16 60 66 61 FAX:+32 16 60 66 75

E-mail : tohnichi-europe@online.be

URL : <http://www.tohnichi.be>

TOHNICHI MFG. CO., LTD. - Stuttgart Liaison Office

Konrad-Zuse-Platz 1, 71034 Boblingen, Germany

TEL:+49 7031 306 973 192 FAX:+49 7031 306 973 200

TOHNICHI AMERICA CORP.

1303 Barclay Blvd. Buffalo Grove, IL 60089 USA

TEL:+1 847 947 8560 FAX:+1 847 947 8572

E-mail : inquiry@tohnichi.com

URL : <http://www.tohnichi.com>

TOHNICHI AMERICA. - Atlanta Office

4046 Hwy 154 Suite 103 Newnan, GA 30265 USA

TEL:+1 678 423 5777 FAX:+1 678 423 1333

TOHNICHI SALES SHANGHAI CO., LTD.

Rm. 5 No. 99 Nong 1919 Du Hui Road Minhang. Shanghai. P. R. China

TEL:+86 21 3407 4008 FAX:+86 21 3407 4135

E-mail : sales@tohnichi-sh.com

URL : <http://www.tohnichi-sh.com/>

Designs and specifications are subject to change without notice.

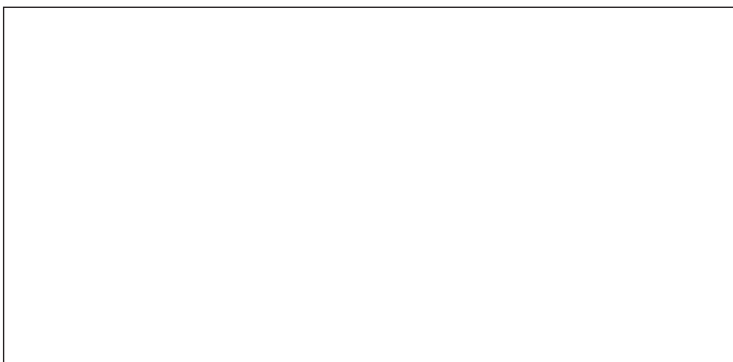

The TUD symbol indicates that our products are ergonomically designed and adapted for Color Vision Deficiencies.