



aerospace  
climate control  
electromechanical  
filtration  
fluid & gas handling  
hydraulics  
**pneumatics**  
process control  
sealing & shielding



# Pneumatic cylinders

Series P1D

According to ISO, VDMA and AFNOR

Catalogue PDE2570TCUK November 2013



ENGINEERING YOUR SUCCESS.

# P1D Series Pneumatic Cylinders

Features	Air cylinder	Hydraulic cylinder	Electro mechanical actuators
Overload safe	***	***	*
Easy to limit force	***	***	*
Easy to vary speed	***	***	*
Speed	***	**	**
Reliability	***	***	***
Robustness	***	***	*
Installation cost	***	*	**
Ease of service	***	**	*
Safety in damp environments	***	***	*
Safety in explosive atmospheres	***	***	*
Safety risk with electrical installations	***	***	*
Risk of oil leak	***	*	***
Clean, hygienic	***	**	*
Standardised measurements	***	***	*
Service life	***	***	*
Hydraulic system required	***	*	***
Weight	**	**	**
Purchase price	***	**	*
Power density	**	***	*
Noise level during operation	**	***	**
High force for size	**	***	*
Positioning possibilities	*	***	***
Total energy consumption	*	**	***
Service interval	*	**	***
Compressor capacity required	*	***	***

\* = good, \*\*=average, \*\*\*=excellent



**Important**  
 Before attempting any external or internal work on the cylinder or any connected components, make sure the cylinder is vented and disconnect the air supply in order to ensure isolation of the air supply.



**Note**  
 All technical data in this catalogue are typical data only.  
 Air quality is essential for maximum cylinder service life (see ISO 8573).



**WARNING**

**FAILURE OR IMPROPER SELECTION OR IMPROPER USE OF THE PRODUCTS AND/OR SYSTEMS DESCRIBED HEREIN OR RELATED ITEMS CAN CAUSE DEATH, PERSONAL INJURY AND PROPERTY DAMAGE.**

This document and other information from Parker Hannifin Corporation, its subsidiaries and authorized distributors provide product and/or system options for further investigation by users having technical expertise. It is important that you analyze all aspects of your application and review the information concerning the product or system in the current product catalog. Due to the variety of operating conditions and applications for these products or systems, the user, through its own analysis and testing, is solely responsible for making the final selection of the products and systems and assuring that all performance, safety and warning requirements of the application are met. The products described herein, including without limitation, product features, specifications, designs, availability and pricing, are subject to change by Parker Hannifin Corporation and its subsidiaries at any time without notice.

**SALE CONDITIONS**

The items described in this document are available for sale by Parker Hannifin Corporation, its subsidiaries or its authorized distributors. Any sale contract entered into by Parker will be governed by the provisions stated in Parker's standard terms and conditions of sale (copy available upon request).

<b>Contents</b>	<b>page</b>
ISO cylinder family, P1D .....	4
P1D Standard .....	6
P1D Clean .....	8
P1D Flexible Porting .....	10
P1D Tie-Rod .....	12
Design variants.....	13-16
Cylinder forces .....	17
Main data: P1D .....	17
Bores and strokes.....	18
Material specification .....	19
Cushioning characteristics.....	19
Valve series with respective flows in NI/minute .....	21
Introduction to the ATEX directive .....	22
Safety instructions for the P1D-S cylinder with accessories.....	24-25
Dimensions and tolerances.....	26-27
Order key P1D Standard and P1D Tie rod .....	28
Order code standard strokes P1D Standard.....	29
Order key for cylinders with factory fitted accessories .....	30-38
Order code standard strokes P1D Clean .....	39-41
Order key P1D Flexible Porting .....	42
Order code standard strokes P1D Flexible Porting .....	43
Order key P1D Clean and P1D Flexible Porting .....	44
P1D complete working unit.....	45-47
P1D cylinder with piston rod locking .....	48-51
P1D with rod guidance modules .....	52-55
Cylinder mountings .....	56-60
Piston rod mountings.....	61-62
Combinations .....	63-64
Accessories.....	65
Complete working unit and 3 and 4 position cylinders .....	66
Sensors .....	67-69
Connecting cables with one connector.....	70
Male connectors for connecting cables.....	70
Connection block Valvetronic 110.....	71
Pneumatic cylinder sensor for P1D-T .....	72-73
P1D Seal kits .....	74-75
Order key, spare parts.....	76
Complete working units – ready for installation.....	77
There is a P1D cylinder for every application .....	78-79
Main order code P1D .....	80-82
Air Reservoirs .....	83



### **ISO cylinder family, P1D**

A completely new cylinder range from the ground up, with major investment in research, material and technology, demands long experience and major resources. When we developed our P1D cylinder range, we started from scratch, but not really. Decades of research and learning about what our customers really need world-wide has given us a very stable foundation to start from.

P1D is a cylinder design of the highest possible quality, every detail has been thought through, without

making any compromises. It has a large number of innovations which could only be achieved by using the best possible materials and methods. The result is a complete family of ISO/VDMA cylinders, of which we are very proud.

P1D is a high technology cylinder design for just about every conceivable application, both simple and highly complex.

## P1D Series Pneumatic Cylinders

The same high technology platform is used for three main versions:

- **P1D Standard** – the universal, general purpose cylinder with high performance and long life.
- **P1D Clean** – the new product level for ISO/VDMA cylinders of clean design with a system of integrated, adjustable sensors (patent applied for), for stringent hygiene demands.
- **P1D Flexible Porting** – the innovative design which saves space and reduces dimensions by allowing connections to be made in the front or rear end of the cylinder.
- **P1D Tie rod** – based on the same high-tech design, the P1D is also available in a tie rod version. This future-proof cylinder is the perfect choice wherever a tie rod cylinder is required.





## P1D Series Pneumatic Cylinders

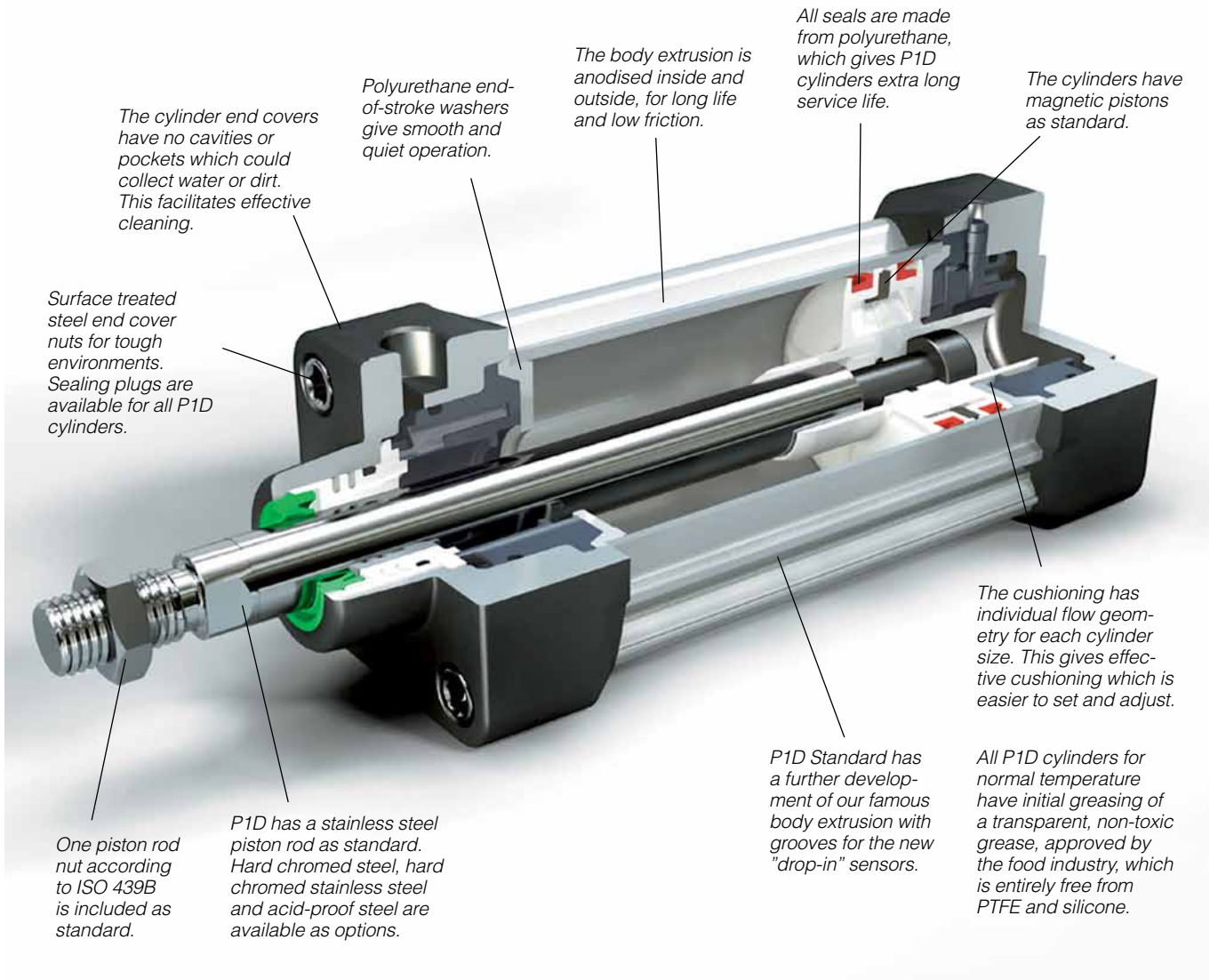

### P1D Standard

The innovative P1D is a future-proof generation of ISO/VDMA cylinders. The cylinders are double-acting, with a new design of air cushioning. The light, stiff body extrusion has sensor grooves for simple and protected sensor installation.

#### Installation dimensions according to international standards

The new P1D complies with the current ISO 6431, ISO 15552, VDMA 24562 and AFNOR installation dimension standards. For customer reassurance world-wide.

#### High technology design

The best materials, manufacturing methods and design of every detail have been carefully tested, to give the best possible product. The internal components are made of high strength plastics, for quiet operation and long service life. The aluminium end caps and the torsionally stiff aluminium body extrusion make the cylinder robust and suitable for a wide range of applications.

#### High quality

The P1D has been developed with quality in all phases – requirement specification, design, planning, purchasing, production, distribution and service. We have been certified under the ISO 9001 QA standard for the past ten years. Quality in all our products and services is our watchword.

#### Even more functions and variants

The P1D is available with all the usual optional designs, such as: Through piston rod, high and low temperature, hydraulic operation, extended piston rod etc.

A new special variant is the unique self-lubricating HDPE scraper ring and piston rod seal, specially designed for operation with a completely dry piston rod (i.e. applications where the film of grease on the piston rod is regularly washed off).

## P1D Series Pneumatic Cylinders

### Complete accessory programme

P1D offers a complete ISO, VDMA and AFNOR compatible accessory programme, with a wide range of piston rod and cylinder mountings for both pivoted and fixed operation. Several of these types of mountings are available in stainless steel. The new "drop-in" sensors are available with both reed and electronic operation, with a wide choice of connector types and cable lengths.



### New, mechanically protected sensor technology

The body extrusion has recessed sensor grooves on three sides of the cylinder. The new sensors are of the "drop-in" type, and are quickly and easily installed in the T-groove from the side. Both the cable and the sensor are protected in the groove. Choose a sensor with 3 or 10 m cable, 8 mm connector or the new M12 connector.



### Optimised cushioning

Thanks to the plastic inserts in the end covers, each cylinder bore has been given individual flow geometry. This provides optimised cushioning, which is quicker and easier to set and adjust.



### Smooth, quiet operation and long service life

All seals and end-of-stroke washers are made from polyurethane (PUR), the bearings and piston are made from proven engineering plastics with excellent bearing properties and all cylinders are greased at the factory with a transparent, foodstuffs-approved grease. Altogether this gives the P1D very long service life and smooth, quiet operation.





### **P1D Clean**

P1D Clean is a new version in our ISO cylinder system, completely designed for the foodstuffs industry. Many years' experience of the stringent requirements for hygiene, choice of material and corrosion resistance, from a wide spectrum of foodstuffs applications have guided the development of this cylinder version. Great emphasis has been put on the external design of the cylinder, choice of materials and corrosion protection.

### **Main dimensions according to international standards**

All the main dimensions of the P1D Clean comply with ISO 6431, ISO 15552, VDMA 24562 and AFNOR standards. The exception is the somewhat larger footprint of the end covers and envelope of the body extrusion, due to the so-called positive geometry (hygienic, convex, easy-to-clean geometry) of the cushioning adjustment screw and the components in the integrated sensor system.

### **Common, high technology design platform**

The P1D Clean has the same technical platform as the P1D Standard. The best materials, including the polyurethane (PUR) seals, manufacturing methods and the careful attention to detail design give the P1D Clean smooth, quiet operation and long service life.

### **Convex shape for optimum hygiene**

P1D Clean has a convex body extrusion, which makes the cylinders easy to keep clean. Irrespective of installation position, fluids run off the body extrusion surfaces.





## P1D Series Pneumatic Cylinders

### Cushioning screw with positive geometry

To offer the best hygiene properties, the projecting cushioning screw, is sealed with rubber seal against the end cover. This eliminates dirt-collecting cavities and gives the best hygiene, since it is so easy to clean.



### Sealing plugs

Four plastic sealing plugs are supplied with every P1D Clean cylinder. These are installed in the end cover screws which are not used for the cylinder installation. To ensure the sealing function, the plugs can be used only once i.e. they can not be re-used. When installed in the end cover screws, they should be tapped lightly with a hammer to securely fix.



### Patent applied system for integrated standard sensors

The P1D Clean cylinder has a system of sensors, which are fully integrated into the body extrusion, to give the cylinders a clean external design. Up to four sensors chosen from the range of P1D standard sensors, reed or electronic operation, can be mounted in two dedicated grooves beneath a transparent, sealed moulding. Tightening the stop screw onto the cam shaft, will lock each sensor in the desired position, with great force. The sensor LEDs are always fully visible, which facilitates commissioning, adjustment and trouble-shooting. The entire sensor system has a hose-proof design, equivalent to IP65. P1D Clean can be ordered with factory-fitted sensors in the end positions, which can then easily be moved to any other position along the entire stroke.



### Up to four integral sensors

Cylinders for two integral sensors have two undivided camshafts along the entire stroke. Free choice of cable exit, front or rear. There is also a version with divided camshafts for up to four sensors, which are installed two from each end cover, with cable exit front and rear.

*The sensors are mounted into their grooves through the opening in a transparent, sealed cover. The sensor cables have strain relief and are sealed.*

*The sensor position is easily adjusted by undoing a set screw and using the cable to move the sensor to the desired position.*

*Once the sensor has been locked in its new position, the protective cover is installed again.*





### **P1D Flexible Porting**

Progress leads to smaller components and machinery. In harmony with this trend, and complying with the main dimension requirements in ISO 6431, we have developed P1D Flexible Porting, which offers new, smarter design solutions. Since one end of the cylinder can be placed in restricted, unused spaces, without needing any connections, the space in the application can be used more efficiently, or made more compact.

### **Main dimensions according to international standards**

Apart from the projecting connections on sizes Ø32–63 mm P1D Flexible Porting complies with ISO 6431, ISO 15552, VDMA 24562 and AFNOR standards.

### **Common, high technology design platform**

P1D Flexible Porting has the same high technology level as P1D Standard and P1D Clean. The future-proof design gives P1D Flexible Porting high performance and long service life.

### **Body extrusion with integrated air channels**

P1D Flexible Porting has the same body extrusion as the P1D Clean cylinder. Since the air is led through channels built into the body extrusion, both connections can be made to either end of the cylinder. The flow capacity of the air channels is big enough not to restrict the cylinder speed in all normal applications.



## P1D Series Pneumatic Cylinders

### Straight or elbow push-in fittings for Ø32-63 mm

For cylinder bore Ø32-63 mm, one connection is located on the body extrusion. The connector from the Moduflex valve range is used for this connection. A matching Prestolok 2 (plastic) fitting is used for the connection at the end cover. Choose between straight or elbow fittings. The other end has a plug installed in the unused cylinder port.



### Threaded connections for Ø80-125 mm

Cylinder bore Ø80-125 mm have two threaded connections located in either end cover. The other end has plugs in the cylinder ports. These plugs can be moved to the other end to suit the application.



### Mechanically protected "drop-in" sensors

The body extrusion, which is common to all P1D Clean and P1D Flexible Porting cylinders, has recessed sensor grooves in the side opening. The geometry has at the same time been designed for "normal" mechanical sensor installation (similar to P1D Standard) and for the built-in sensor system (P1D Clean). Use standard sensors in the usual way.



### Combine with P1D Clean

For compact applications with stringent hygiene requirements, P1D Clean can be combined with Flexible Porting. This cylinder version complies with many different requirements and offers new opportunities for creating effective application solutions.





### **P1D Tie-Rod**

The P1D is available in a tie-rod version, based on the same high level technology. This future-proof cylinder is the perfect choice wherever a tie-rod cylinder is needed.

#### **Installation dimensions to international standard**

The P1D Tie-Rod complies with ISO 6431, ISO 15552, VDMA 24562 and AFNOR installation dimension standards. For customer reassurance world-wide.

#### **Smooth, quiet operation and long service life**

All seals and end-of-stroke washers are made from polyurethane (PUR), the bearings and piston are made from proven engineering plastics with excellent bearing properties and the initial greasing at the factory with a transparent, foodstuffs-approved grease. Altogether this gives the P1D very long service life and gentle, quiet operation.

#### **Optimised cushioning**

Thanks to the plastic inserts in the end covers, each cylinder bore has been given an individual flow geometry. This gives an optimised cushioning, which is quicker and easier to set and adjust.

#### **Complete accessory programme**

P1D offers a complete ISO, VDMA and AFNOR compatible accessory programme, with a wide range of piston rod and cylinder mountings for both pivoted and fixed operation.

#### **"Drop-in" sensor**

The P1D Tie-Rod uses "drop-in" P1D sensors. An ingenious multi-jointed adapter fixes the sensors in any chosen position along the stroke.

**Design variants for P1D Standard, P1D Clean, P1D Flexible porting and P1D Tie-Rod**

Using P1D cylinders as a platform, a number of different designs can be produced to suit differing requirements. Please refer to the order key on pages 28 - 51 for the designation of each variant.

**P1D complete working unit**

P1D Standard can be ordered with a factory-fitted valve and piping. The valve series is the robust and compact Viking series.

Of course, the entire range of P1D accessories can also be used for the P1D with built-in valve, and cylinders can be ordered with factory-fitted accessories and sensors.

For more information, see page 45.

**P1D cylinder with piston rod locking**

The P1D cylinder is available in a version with piston rod locking, allowing the piston rod to be locked in any position. The lock unit, of the air/spring actuated type, is integrated in the front end piece of the cylinder. The lock unit can be used for braking as well as locking. With no signal pressure, the full force of the lock is applied to the piston rod, and the lock is released at 4 bar signal pressure. Lock units are available for P1D Standard

(P1D-L) and P1D Clean (P1D-D) in dimensions Ø32-125 mm. P1D Standard can be ordered with a lock unit and a built-in valve (P1D-4).

For more information, see page 48

P1D-L



P1D-D

**P1D cylinder with internal piston rod thread**

All P1D cylinders are available with an internal piston rod thread where a short installation length is required





**Design variants for P1D Standard, P1D Clean, P1D Flexible porting and P1D Tie-Rod****Alternative piston rod materials**

All P1D cylinders in all bores, Ø32-125 mm, can be ordered with the following piston rod materials:

- Steel, hard chromed
- Stainless steel, roller polished (standard)
- Acid-proof steel, roller polished
- Stainless steel, hard chromed

**Through piston rod**

All P1D cylinders in all bores, Ø32-125 mm, are available with a through rod. Cylinders with a through rod can take higher side forces thanks to the double support for the piston rod. In addition, this design makes it easier to install external position sensors.

**Low and high ambient temperature**

For all bores, Ø32-125 mm, the P1D can be supplied in special high ambient temperature and low ambient temperature versions. The cylinders have seal systems, materials and grease for their particular temperature ranges. The high temperature version does not have magnetic piston (no function at high temperatures). The low temperature cylinders do have magnetic piston, but remember that most sensors are specified to -25 °C (no function below this temperature).

Ambient temperature ranges:

- Low temperature: -40 °C to +40 °C
- High temperature: -10 °C to +150 °C, peaks up to +200 °C

**Low pressure hydraulics**

The P1D in bores Ø32 - 125 mm can be supplied with special seals for operation with low pressure hydraulics up to 10 bar. Temperature range -20 °C to +80°C.



**Design variants for P1D Standard, P1D Clean, P1D Flexible porting and P1D Tie-Rod**

**Operation with dry piston rod**

In many applications, primarily in the foodstuffs industry, the cylinders are cleaned frequently. This means that the film of grease on the piston rod is washed off, which puts special demands on the materials and the design of the piston rod seal system (scraper ring and piston rod seal). A piston rod seal system specially designed for dry rod operation is available as options for this type of application, for all bores of P1D cylinders. The system has a specially designed L-shaped seal and the material is self-lubricating, high molecular weight plastics (HDPE) – the same system as in our previous P1C cylinders, with proven function.



**P1D with metal scraper ring**

Standard scraper rings cannot be used in environments where the piston rod may be coated with resin, ice, cement, sugar crystals, dough, etc., primarily in timber handling, refrigerated/ chilled transport, cement industry, chemicals and food and drinks. Hard and dirty coatings damage the standard scraper rings and shorten their service life, introducing dirt into the cylinder. A scraper ring has been specially designed for applications of this kind, as an option for all diameters of P1D-S, P1D-T and P1D-V cylinders. The scraper ring, which requires a hard-chromium plated piston rod, has a stainless steel carrier, a brass outer scraper ring and a nitrile rubber inner scraper ring.



**Scraper for high chemical resistance**

For use in applications where chemicals may affect the scraper in the front end cover, an option with a scraper in FPM rubber for better chemical resistance must be used



**Design variants for P1D Standard, P1D Clean, P1D Flexible porting and P1D Tie-Rod****3 and 4 position cylinders**

By installing two cylinders with the same or different stroke, it is possible to build a working unit with three or four positions. This type of unit is available as factory-fitted P1D tie-rod cylinders (P1D-T) in all bores, Ø32-125 mm. Other P1D cylinders can be flange mounted back-to-back with a special mounting (see pages 59 and 66).

**Tandem version**

The P1D is also available as a tandem cylinder, i.e. two cylinders connected in series. This cylinder unit has almost twice the force, which is a great advantage in restricted spaces. Tandem cylinders are available as tie-rod cylinders, P1D-T, in all bores Ø32-125 mm.



## P1D Series Pneumatic Cylinders

### Cylinder forces, double acting variants

Cyl. bore/ pist. rod mm	Stroke	Pistonarea cm <sup>2</sup>	Max theoretical force in N (bar)									
			1,0	2,0	3,0	4,0	5,0	6,0	7,0	8,0	9,0	10,0
32/12	+	8,0	80	161	241	322	402	483	563	643	724	804
	-	6,9	69	138	207	276	346	415	484	553	622	691
40/16	+	12,6	126	251	377	503	628	754	880	1005	1131	1257
	-	10,6	106	212	318	424	530	636	742	848	954	1060
50/20	+	19,6	196	393	589	785	982	1178	1374	1571	1767	1963
	-	16,5	165	330	495	660	825	990	1155	1319	1484	1649
63/20	+	31,2	312	623	935	1247	1559	1870	2182	2494	2806	3117
	-	28,0	280	561	841	1121	1402	1682	1962	2242	2523	2803
80/25	+	50,3	503	1005	1508	2011	2513	3016	3519	4021	4524	5027
	-	45,4	454	907	1361	1814	2268	2721	3175	3629	4082	4536
100/25	+	78,5	785	1571	2356	3142	3927	4712	5498	6283	7069	7854
	-	73,6	736	1473	2209	2945	3682	4418	5154	5890	6627	7363
125/32	+	122,7	1227	2454	3682	4909	6136	7363	8590	9817	11045	12272
	-	114,7	1147	2294	3440	4587	5734	6881	8027	9174	10321	11468

+ = Outward stroke  
- = Return stroke

#### Note!

Select a theoretical force 50-100% larger than the force required

### Main data: P1D

Cylinder designation	Cylinder		Piston rod		Cushioning length	Air consumption <sup>2)</sup>	Connection thread	Flexible Porting tubing dimension	
	bore	area	dia.	area					
	mm	cm <sup>2</sup>	mm	cm <sup>2</sup>	mm	litre		Push-in mm	
P1D-•032•-XXXX <sup>1)</sup>	32	8,0	12	1,1	M10x1,25	17	0,105	G1/8	4 or 6
P1D-•040•-XXXX <sup>1)</sup>	40	12,6	16	2,0	M12x1,25	19	0,162	G1/4	4 or 6
P1D-•050•-XXXX <sup>1)</sup>	50	19,6	20	3,1	M16x1,5	20	0,253	G1/4	8 or 10
P1D-•063•-XXXX <sup>1)</sup>	63	31,2	20	3,1	M16x1,5	23	0,414	G3/8	8 or 10
P1D-•080•-XXXX <sup>1)</sup>	80	50,3	25	4,9	M20x1,5	23	0,669	G3/8	-
P1D-•100•-XXXX <sup>1)</sup>	100	78,5	25	4,9	M20x1,5	27	1,043	G1/2	-
P1D-•125•-XXXX <sup>1)</sup>	125	122,7	32	8,0	M27x2	30	1,662	G1/2	-

### Total mass including moving parts

Cylinder designation	Total mass (kg) at 0 mm stroke			Supplement mass (kg) for rod locking All variants	Total mass (kg) Supplement per 10 mm stroke		
	Standard	Tie-Rod	Clean/Flex		Standard	Tie-Rod	Clean/Flex
P1D-•032•-X	0,55	0,54	0,60	0,31	0,023	0,022	0,047
P1D-•040•-X	0,80	0,79	0,88	0,44	0,033	0,030	0,063
P1D-•050•-X	1,20	1,20	1,32	0,61	0,048	0,048	0,094
P1D-•063•-X	1,73	1,73	1,86	1,25	0,051	0,051	0,101
P1D-•080•-X	2,45	2,47	2,63	2,45	0,075	0,079	0,142
P1D-•100•-X	4,00	4,00	4,22	3,72	0,084	0,084	0,168
P1D-•125•-X	6,87	6,73	7,01	6,07	0,138	0,129	0,248

### Mass moving parts only (for cushioning calculation)

Cylinder designation	Mass moving parts(kg)	
	at 0 mm stroke All variants	Supplement per 10 mm stroke All variants
P1D-•032•-X	0,13	0,009
P1D-•040•-X	0,24	0,016
P1D-•050•-X	0,42	0,025
P1D-•063•-X	0,50	0,025
P1D-•080•-X	0,90	0,039
P1D-•100•-X	1,10	0,039
P1D-•125•-X	2,34	0,063

1) Stroke

2) Free air consumption per 10 mm stroke for a double stroke at 6 bar

# P1D Series Pneumatic Cylinders

## Standard stroke

Standard strokes for all P1D cylinders comply with ISO 4393. (\* 40 is not an ISO standard stroke)  
 Special strokes up to 2800 mm.  
 Minimum stroke for P1D Clean is 25 mm with 0-2 sensors and 100 mm with 3-4 sensors.

Order no XXXX = Stroke	Cylinder bore (mm)	● = Standard stroke (mm)											= Stroke to special order					
		25	40	50	80	100	125	160	200	250	320	400	500	600	700	800	2800	
<b>Double acting Profile cylinder</b>																		
<b>P1D-S032MS-XXXX</b>	<b>32</b>		●	●	●	●	●	●	●	●	●	●	●	●	●	●	///	
<b>P1D-S040MS-XXXX</b>	<b>40</b>		●	●	●	●	●	●	●	●	●	●	●	●	●	●	///	
<b>P1D-S050MS-XXXX</b>	<b>50</b>		●	●	●	●	●	●	●	●	●	●	●	●	●	●	///	
<b>P1D-S063MS-XXXX</b>	<b>63</b>		●	●	●	●	●	●	●	●	●	●	●	●	●	●	///	
<b>P1D-S080MS-XXXX</b>	<b>80</b>		●	●	●	●	●	●	●	●	●	●	●	●	●	●	///	
<b>P1D-S100MS-XXXX</b>	<b>100</b>		●	●	●	●	●	●	●	●	●	●	●	●	●	●	///	
<b>P1D-S125MS-XXXX</b>	<b>125</b>		●	●	●	●	●	●	●	●	●	●	●	●	●	●	///	

## Operation data

Working pressure	Max 10 bar
Working temperature	min max
Standard	-20 °C +80 °C

Greased for life, does not normally need additional lubrication. If extra lubrication is given, this must always be continued.

## Working medium, air quality

Working medium Dry, filtered compressed air  
 to ISO 8573-1 class 3.4.3.

## Bores and strokes

P1D	32 - 125 mm
Standard strokes	25 - 500 mm according to ISO 4393
Max stroke	2800 mm
Min stroke, P1D Clean	25 mm (0-2 sensors) 100 mm (3-4 sensors)

## P1D Clean

Protection class	Hose-proof in accordance with IP65
Chemical resistance	Tested for normally used industrial detergents, both acid and alkaline

## Recommended air quality for cylinders

For best possible service life and trouble-free operation, ISO 8573-1 quality class 3.4.3 should be used. This means 5 µm filter (standard filter) dew point +3 °C for indoor operation (a lower dew point should be selected for outdoor operation) and oil concentration 1.0 mg oil/m³, which is what a standard compressor with a standard filter gives.

## ISO 8573-1 quality classes

Quality class	Pollution		Water max. press. dew point (°C)	Oil max concentration (mg/m³)
	particle size (µm)	max concentration (mg/m³)		
<b>1</b>	0,1	0,1	-70	0,01
<b>2</b>	1	1	-40	0,1
<b>3</b>	5	5	-20	1,0
<b>4</b>	15	8	+3	5,0
<b>5</b>	40	10	+7	25
<b>6</b>	-	-	+10	-



**Important!**  
 If the cylinder is used in applications with significant lateral loads on the piston rod, an external guide must be used to achieve maximum service life. See the examples on pages 52-55.



## Material specification

### Standard design

Body extrusion	Natural colour, anodised aluminium
End cover	Black anodised aluminium
End cover inserts	POM
End cover nuts/screws	Zinc plated steel 8.8
Piston rod nut	Zinc plated steel
Piston rod	Stainless steel, X 10 CrNiS 18 9
Scraper ring	PUR
Piston rod bearing	POM
Piston	POM
Piston bearing	POM
Magnetic ring	Plastic bound magnetic material
Piston bolt	Zinc plated steel
Piston seal	PUR
O-rings	Nitrile rubber, NBR
End-of-stroke washers	PUR
Cushioning seals	PUR
Cushioning screws	LCP

### P1D Clean

Transparent moulding	Silicone
Transparent cover	ABS
Screws, sensor system	Stainless steel, A2
Upper seal and lower seal, protective cover	Santopren
Sealing plugs	PA
Piston rod nut	Stainless steel, A2

### P1D Flexible Porting

Connection part Ø32-63	POM
Elbow fittings Ø32-63	PA
Straight fittings on body extrusion Ø32-63	PA
Straight fittings in ports	Nickel plated brass
Seal, connection part	Nitrile rubber NBR

### P1D Tie-Rod

Tie-rods	Stainless steel, X 10 CrNiS 18 9
----------	----------------------------------

### Design variants

Cylinders for dry rod operation	
Seals/scraper ring	FPM/HDPE
Option	
Piston rod material	Hard-chromium plated steel, Fe 490-2 FN Acid-proof steel, X 5 CrNiMo 17 13 3 Hard-chromium plated stainless steel, X 10 CrNiS 18 9

## Cushioning characteristics

The diagram below is used for dimensioning of cylinders related to the cushioning capacity. The maximum cushioning capacity shown in the diagram assumes the following:

- Low load, i.e. low pressure drop across the piston
- Equilibrium speed
- Correctly adjusted cushioning screw
- 6 bar at cylinder port

The load is the sum of internal and external friction, plus any gravitational forces. At high relative load (pressure drop exceeding 1 bar), we recommend that for any given speed, the mass should be reduced by a factor of 2.5, or for a given mass, the speed should be reduced by a factor of 1.5. This is in relation to the maximum performance given in the diagram

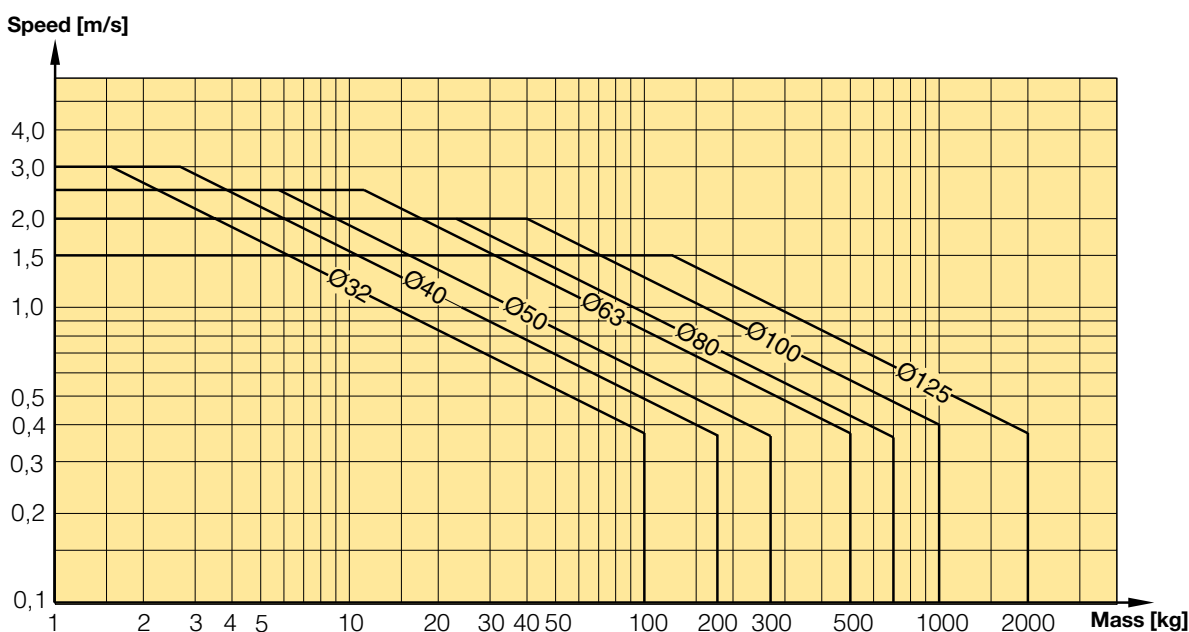

**Guide for selecting suitable tubing**

The selection of the correct size of tubing is often based on experience, with no great thought to optimizing energy efficiency and cylinder velocity. This is usually acceptable, but making a rough calculation can result in worthwhile economic gains.

**The following is the basic principle:**

1. The primary line to the working valve could be over sized (this does not cause any extra air consumption and consequently does not create any extra costs in operation).
2. The tubes between the valve and the cylinder should, however, be optimized according to the principle that an insufficient bore throttles the flow and thus limits the cylinder speed, while an oversized pipe creates a dead volume which increases the air consumption and filling time.

The chart below is intended to help when selecting the correct size of tube to use between the valve and the cylinder.

**The following prerequisites apply:**

The *cylinder load should be about 50%* of the theoretical force (= normal load). A lower load gives a higher velocity and vice versa. The tube size is selected as a function of the *cylinder bore*, the desired *cylinder velocity* and the *tube length* between the valve and the cylinder.

If you want to use the capacity of the valve to its maximum, and obtain maximum speed, the tubing should be chosen so that they at least correspond with the equivalent restriction diameter (see description below), so that the tubing does not restrict the total flow. This means that a short tubing must have at least the equivalent restriction diameter. If the tubing is longer, choose it from the table below. Straight fittings should be chosen for highest flow rates. (Elbow and banjo fittings cause restriction.)

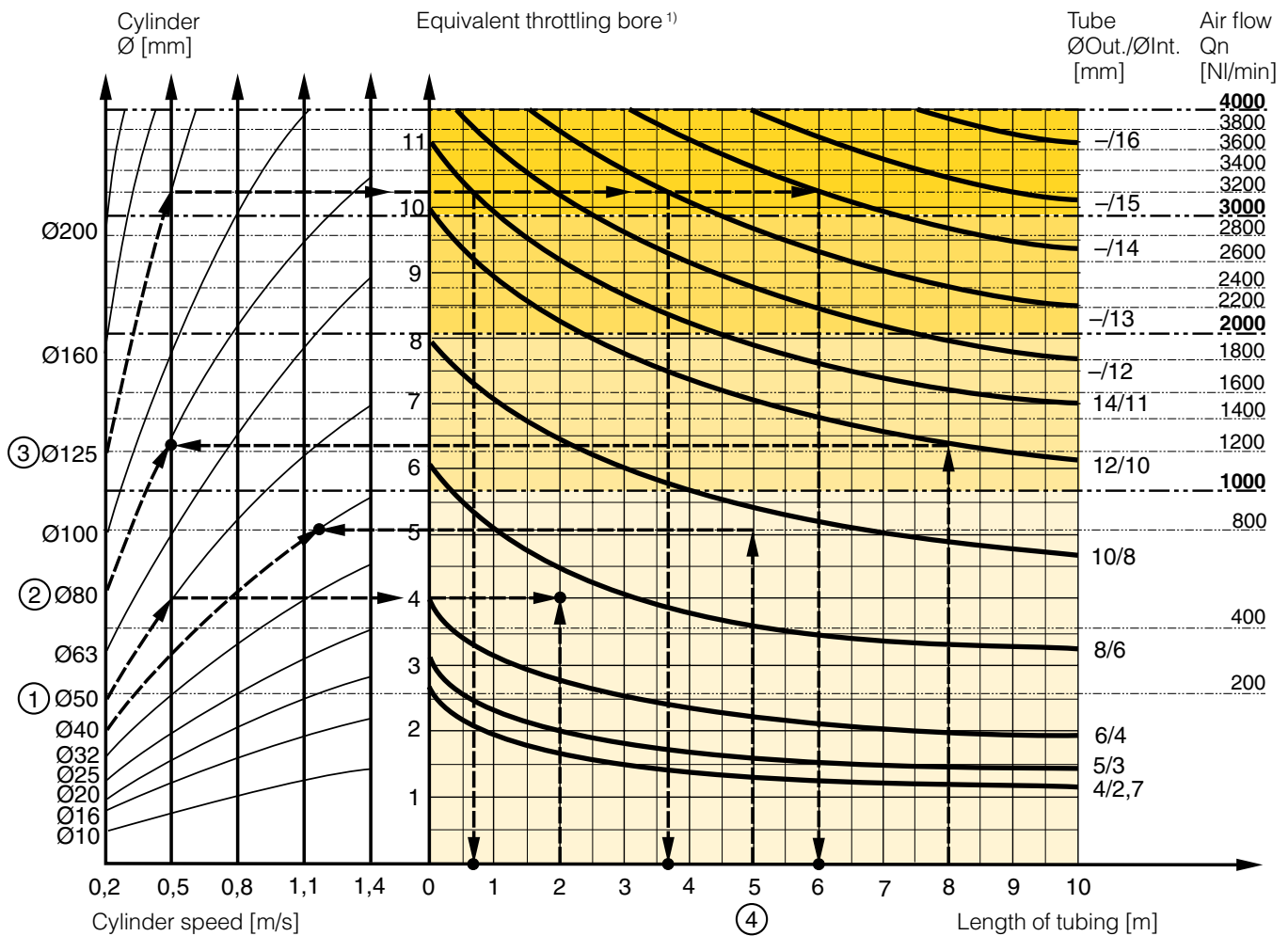

- 1) The “equivalent throttling bore” is a long throttle (for example a tube) or a series of throttles (for example, through a valve) converted to a short throttle which gives a corresponding flow rate. This should not be confused with the “orifice” which is sometimes specified for valves. The value for the orifice does not normally take account of the fact that the valve contains a number of throttles.
- 2) Qn is a measure of the valve flow capacity, with flow measured in litre per minute (l/min) at 6 bar(e) supply pressure and 1 bar pressure drop across the valve.

## P1D Series Pneumatic Cylinders

### Example ①: Which tube diameter should be used?

A 50 mm bore cylinder is to be operated at 0.5 m/s. The tube length between the valve and cylinder is 2 m. In the diagram we follow the line from 50 mm bore to 0.5 m/s and get an "equivalent throttling bore" of approximately 4 mm. We continue out to the right in the chart and intersect the line for a 2 m tube between the curves for 4 mm (6/4 tube) and 6 mm (8/6 tube). This means that a 6/4 tube throttles the velocity somewhat, while an 8/6 tube is a little too large. We select the 8/6 tube to obtain full cylinder velocity.

### Example ②: What cylinder velocity will be obtained?

A 80 mm bore cylinder will be used, connected by 8 m 12/10 tube to a valve with Qn 1200 NI/min. What cylinder velocity will we get? We refer to the diagram and follow the line from 8 mm tube length up to the curve for 12/10 tube. From there, we go horizontally to the curve for the Ø80 cylinder. We find that the velocity will be about 0.5 m/s.

### Example ③: What is the minimum inner diameter and maximum length of tube?

For a application a 125 mm bore cylinder will be used. Maximum velocity of piston rod is 0.5 m/s. The cylinder will be controlled by a valve with Qn 3200 NI/min. What diameter of tube can be used and what is maximum length of tube. We refer to the diagram. We start at the left side of the diagram cylinder Ø125. We follow the line until the intersection with the velocity line of 0.5 m/s. From here we draw a horizontal line in the diagram. This line shows us we need an equivalent throttling bore of approximately 10 mm. Following this line horizontally we cross a few intersections. These intersections shows us the minimum inner diameter (rightside diagram) in combination with the maximum length of tube (bottomside diagram).

For example:

Intersection one: When a tube (14/11) will be used, the maximum length of tube is 0.7 meter.

Intersection two: When a tube (—/13) will be used, the maximum length of tube is 3.7 meter.

Intersection three: When a tube (—/14) will be used, the maximum length of tube is 6 meter.

### Example ④: Determining tube size and cylinder velocity with a particular cylinder and valve?

For an application using a 40 mm bore cylinder with a valve with Qn=800 NI/min. The distance between the cylinder and valve has been set to 5 m.

**Tube dimension:** What tube bore should be selected to obtain the maximum cylinder velocity? Start at pipe length 5 m, follow the line up to the intersection with 800 NI/min. Select the next largest tube diameter, in this case Ø10/8 mm.

**Cylinder velocity:** What maximum cylinder velocity will be obtained? Follow the line for 800 NI/min to the left until it intersects with the line for the Ø40 mm cylinder. In this example, the speed is just above 1.1 m/s.

### Valve series with respective flows in NI/minute

Valve series	Qn in NI/Min
Valvetronic Solstar	33
Interface PS1	100
Adex A05	173
Moduflex size 1, (2 x 3/2)	220
Valvetronic PVL-B 5/3 closed centre, 6 mm push in	290
Moduflex size 1, (4/2)	320
B43 Manual and mechanical	340
Valvetronic PVL-B 2 x 2/3, 6 mm push in	350
Valvetronic PVL-B 5/3 closed centre, G1/8	370
Compact Isomax DX02	385
Valvetronic PVL-B 2 x 3/2 G1/8	440
Valvetronic PVL-B 5/2, 6 mm push in	450
Valvetronic PVL-B 5/3 vented centre, 6 mm push in	450
Moduflex size 2, (2 x 3/2)	450
Flowstar P2V-A	520
Valvetronic PVL-B 5/3 vented centre, G1/8	540
Valvetronic PVL-B 5/2, G1/8	540
Valvetronic PVL-C 2 x 3/2, 8 mm push in	540
Adex A12	560
Valvetronic PVL-C 2 x 3/2 G1/8	570
Compact Isomax DX01	585
VIKING Xtreme P2LAX	660
Valvetronic PVL-C 5/3 closed centre, 8 mm push in	700
Valvetronic PVL-C 5/3 vented centre, G1/4	700
B3-Series	780
Valvetronic PVL-C 5/3 closed centre, G1/4	780
Moduflex size 2, (4/2)	800
Valvetronic PVL-C 5/2, 8 mm push in	840
Valvetronic PVL-C 5/3 vented centre, 8 mm push in	840
Valvetronic PVL-C 5/2, G1/4	840
Flowstar P2V-B	1090
ISOMAX DX1	1150
B53 Manual and mechanical	1160
B4-Series	1170
VIKING Xtreme P2LBX	1290
B5-Series, G1/4	1440
Airline Isolator Valve VE22/23	1470
ISOMAX DX2	2330
VIKING Xtreme P2LCX, G3/8	2460
VIKING Xtreme P2LDX, G1/2	2660
ISOMAX DX3	4050
Airline Isolator Valve VE42/43	5520
Airline Isolator Valve VE82/83	13680

**Introduction to the ATEX directive**

**Explosive atmospheres**

Directive 94/9/EC defines an explosive atmosphere as a mixture of:

- a) **flammable substances** – gases, vapours, mists or dusts
  - b) with **air**
  - c) under specific **atmospheric conditions**
  - d) in which, after ignition has occurred, combustion spreads to the entire flammable mixture
- (NB: with regard to dust, it may be that not all dust is combusted after ignition has occurred)

An atmosphere with the potential to become an explosive atmosphere during operating conditions and/or under the influence of the surroundings is defined as a **potentially explosive atmosphere**. Products covered by directive 94/9/EC are defined as intended for use in potentially explosive atmospheres.

**Harmonised European ATEX standard**

The European Union has adopted two harmonised directives in the field of health and safety. The directives are known as ATEX 100a and ATEX 137.

Directive ATEX 100a (94/9/EC) lays down minimum safety requirements for products intended for use in potentially explosive atmospheres in European Union member states. Directive ATEX 137 (99/92/EC) defines minimum requirements for health and safety at the workplace, for working conditions and for the handling of products and materials in potentially explosive atmospheres. This directive also divides the workplace into **zones** and defines criteria by which products are **categorised** within these zones.

The table below describes the **zones** in an installation where there is a potential for explosive atmospheres. The **owner** of the installation must analyse and assess the area in which the explosive gas/dust mixture may occur, and if necessary must divide it into **zones**. This process of zoning then allows the correct plant and equipment to be selected for use in the area.

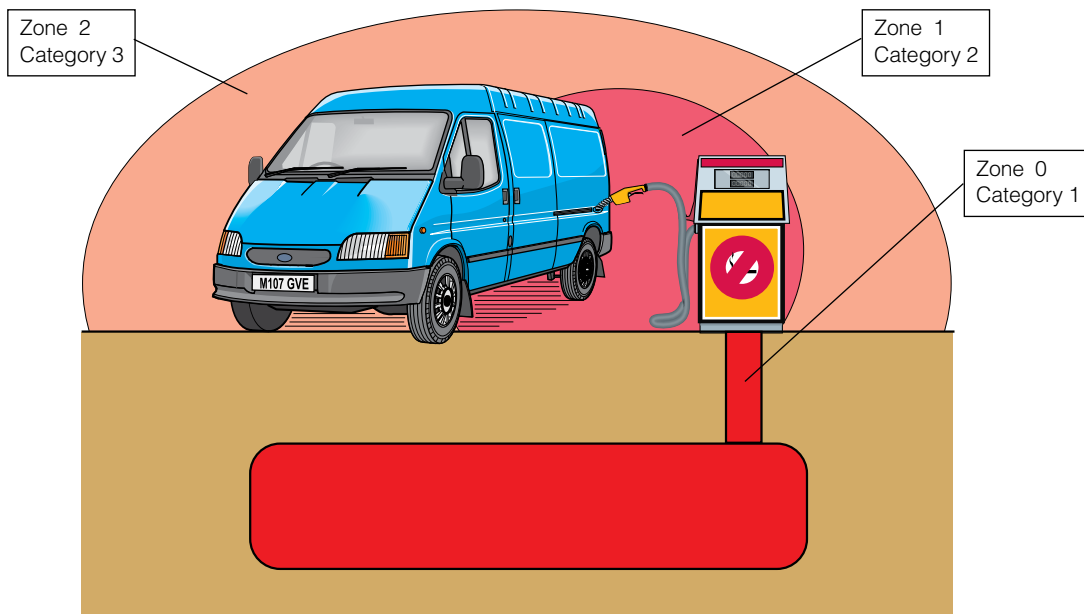

Zones		Presence of potentially explosive atmosphere	Type of risk
Gas G	Dust D		
0	20	Present continuously or for long periods	Permanent
1	21	Likely to occur in normal operation occasionally	Potential
2	22	Not likely to occur in normal operation but, if it does occur, will persist for a short period only	Minimal

The ATEX directive has been in force throughout the European Union since 1 July 2003, replacing the existing divergent national and European legislation relating to explosive atmospheres. Please note that for the first time, the directive covers mechanical, hydraulic and pneumatic equipment and not just electrical equipment as before.

With regard to the **Machinery directive 98/37/EC**, note that a number of external requirements in 94/9/EC refer to hazards arising from potentially explosive atmospheres, where the Machinery directive only contains general requirements relating to explosion safety (Annex I 1.5.7).

As a result, directive 94/9/EC (ATEX 100a) takes precedence over the Machinery directive with regard to explosion protection in potentially explosive atmospheres. The requirements in the Machinery directive are applicable to all other risks relating to machinery.

# P1D Series Pneumatic Cylinders

## Levels of protection for the various equipment categories

The various equipment categories must be capable of operating in accordance with the manufacturer's operating specifications at defined levels of protection.

Level of protection	Category		Type of protection	Operating specifications
	Group I	Group II		
Very high	M1		Two independent means of protection or safety, ensuring that the equipment remains functional even in the event of two faults occurring independently of each other	The equipment remains energised and functional even with an explosive atmosphere present
Very high		1	Two independent means of protection or safety, ensuring that the equipment remains functional even in the event of two faults occurring independently of each other	The equipment remains energised and functional in zones 0, 1, 2 (G) and/or zones 20, 21, 22 (D)
High	M2		Protection suitable for normal operation and severe operating conditions	The equipment is de-energised in the event of an explosive atmosphere
High		2	Protection suitable for normal operation and frequent faults, or equipment in which faults normally have to be taken into account	The equipment remains energised and functional in zones 1, 2 (G) and/or zones 21, 22 (D)
Normal		3	Protection suitable for normal operation	The equipment remains energised and functional in zones 2 (G) and/or zones 22 (D)

### Definition of groups (EN 1127-1)

**Group I** Equipment intended for use in underground parts of mines as well as those parts of surface installations of such mines likely to be endangered by flammable vapours and/or flammable dusts.

**Group II** Equipment intended for use in other places exposed to explosive atmospheres.

Group	I mines, combustible vapours		II other potentially explosive atmospheres (gases, dust)					
	M1	M2	1		2		3	
Category								
Atmosphere*			G	D	G	D	G	D
Zone			0	20	1	21	2	22

G = gas and D = dust

### Temperature classes

Classification of flammable gases and vapours on the basis of ignition temperature

Temperature class	Ignition temperature °C
T1	Over 450
T2	(300) – 450
T3	(200) – 300
T4	(135) – 200
T5	(100) – 135
T6	(85) - 100

### Declaration of conformity

The product catalogues contain copies of the declaration of conformity demonstrating that the product meets the requirements of directive 94/9/EC.

The declaration is only valid in conjunction with the instructions contained in the installation manual relating to the safe use of the product throughout its service life.

The instructions relating to the conditions in the surrounding area are particularly important, as the certificate is invalidated if the instructions are found not to have been adhered to during operation of the product. If there is any doubt as to the validity of the certificate of conformity, contact Parker Hannifin customer service.

### Operation, installation and maintenance

The installation manual of the product contains instructions relating to the safe storage, handling, operation and servicing of the product.

The manual is available in different languages, and can be downloaded from [www.parker.com/euro\\_pneumatic](http://www.parker.com/euro_pneumatic).

This document must be made accessible in a suitable place near where the product is installed. It is used as a reference for all personnel authorised to work with the product throughout its service life.

We, the manufacturer, reserve the right to modify, extend or improve the installation manual in the interests of the users.

For more information about ATEX see EUs homepage: <http://europa.eu.int/comm/enterprise/ates/>





## Safety instructions for the P1D-S cylinder with accessories

### Supplementary safety instructions for P1D-S cylinders installed in Ex-areas

**Serious, even fatal, damage or injury may be caused by the hot moving parts of the P1D cylinders in the presence of explosive gas mixtures and concentrations of dust.**

All installation, connection, commissioning, servicing and repair work on P1D cylinders must be carried out by qualified personnel taking account of the following

- These instructions
- Markings on the cylinder
- All other planning documents, commissioning instructions and connection diagrams associated with the application.
- Provisions and requirements specific to the application
- National/international regulations (explosion protection, safety and accident prevention)

### Real life applications

P1D cylinders are designed to provide linear movement in industrial applications, and should only be used in accordance with the instructions in the technical specifications in the catalogue, and within the operating range indicated on the rating plate. The cylinders meet the applicable standards and requirements of directive 94/9/EC (ATEX)

The cylinders must not be used underground in mines susceptible to firedamp and/or flammable dusts. The cylinders are intended for use in areas in which explosive atmospheres caused by gases, vapours or mists of flammable liquids, or air/dust mixtures may be expected to occur during normal use (infrequently)

### Checklist

Before using the cylinders in an Ex-area, you should check the following:

Do the specifications of the P1D-S cylinder match the Ex-classification of the area of use in accordance with directive 94/9/EC (previously ATEX 100a)

- Equipment group
- Ex-equipment category
- Ex-zone
- Temperature class
- Max. surface temperature

1. When installing the P1D-S cylinder, is it certain that there is no potentially explosive atmosphere, oil, acids, gases, vapours or radiation?
2. Is the ambient temperature as specified in the technical data in the catalogue at all times?
3. Is it certain that the P1D-S cylinder is adequately ventilated and that no forbidden additional heat is added?
4. Are all the driven mechanical components ATEX certified?
5. Check that the P1D-S cylinder is safely earthed.
6. Check that the P1D-S cylinder is supplied with compressed air. Explosive gas mixtures must not be used for driving the cylinder.
7. Check that the P1D-S cylinder is not equipped with a metal scraper ring (special version).

### Installation requirements in Ex-areas

- The temperature of the supply air must not exceed the ambient temperature.
- The P1D-S cylinder may be installed in any position.
- An air treatment unit must be attached to the inlet of the P1D-S cylinder.
- The P1D-S cylinder must be connected to earth at all times, through its support, a metallic tube or separate conductor.
- The outlet of the P1D-S cylinder must not be open within an Ex-area, but must be connected to the silencer or, preferably, piped and released outside the Ex-area.
- The P1D-S cylinder may only drive units that are ATEX certified.
- Ensure that the P1D-S cylinder is not exposed to forces greater than those permitted in accordance with the catalogue
- The P1D-S cylinder must be supplied with compressed air. Explosive gas mixtures must not be used
- P1D-S cylinders with metal scraper rings must not be used in Ex-areas

### Inspecting cylinders during operation

The P1D cylinder must be kept clean on the outside, and a layer of dust/dirt thicker than 1 mm must never be allowed to form. Strong solvents should not be used for cleaning, because they can cause the seal (material PUR) around the piston rod to swell, potentially increasing the temperature. Inspect and verify that the cylinder, with attachments, compressed air fittings, hoses, tubes, etc. meet the standards of "safe" installation.

### Marking of cylinder P1D-S Standard (P1D-S\*\*\*MS-\*\*\*\*)



Communauté Européenne = EU  
CE on the product shows that Parker Hannifin products meet one or more EU directives.



Ex means that this product is intended for use in potentially explosive atmospheres.

II

Stands for the equipment group (I = mines and II = other hazardous areas).

2GD

Stands for equipment category 2G means the equipment can be used in zones 1 and 2 where there is a risk involving gases, vapours or mists of combustible liquids and 2D in zones 21 and 22 where there is a risk involving dusts. 2GD Means the equipment can be used in zones 1, 2, 21 and 22.

c

Safe design (prEN 13463-5)

T4

If equipment is in temperature class T4, the maximum surface temperature must not exceed 135 °C. (To guarantee this, the product has been tested to ensure that the maximum is 130 °C. This provides a safety margin of 5 °K).

120 °C

Maximum permitted surface temperature on P1D-S cylinder in atmospheres containing potentially explosive dusts.

## P1D Series Pneumatic Cylinders

### Supplementary safety instructions for P8S- GPFLX/ EX sensors installed in Ex-areas

Serious, even fatal, damage or injury may be caused by the hot moving parts of the P1D cylinders in the presence of explosive gas mixtures and concentrations of dust.

#### Instructions for use

##### Safety instructions

- Cylinder sensor ATEX classed for category II3G and II3D
- Ambient temperature  $T_a = -20\text{ °C}$  to  $+45\text{ °C}$
- Temperature class T4, or max. surface temperature of  $T = 135\text{ °C}$
- Protection class IP67
- Read installation instructions before startup
- Installation, connection and commissioning must be carried out by trained personnel

##### Applications

- This sensor is designed for use in the T-groove of cylinders, and detects the magnetic field in potentially explosive areas. The sensor can only be installed in the T-groove of these cylinders.
- The sensor may also be installed on round cylinders by means of the following attachments:

**P8S-TMC01** Suitable for P1S and P1A diameter 10 - 25 mm

**P8S-TMC02** Suitable for P1S diameter 32 - 63 mm

**P8S-TMC03** Suitable for P1S diameter 80 - 125 mm

The following data applies to these attachments:

- Ambient temperature  $T_a = 0\text{ °C}$  to  $45\text{ °C}$
- Low energy absorption to EN 50 021
- The sensor may also be installed on tie-rod cylinders or profile cylinders by means of this attachment:  
**P8S-TMA0X** Suitable for P1D-T diameter 32 - 125 mm, P1E-T diameter 160 – 200 mm and C41 diameter 160 – 200 mm

##### Installation

General: The sensor must be protected from UV radiation. The cable must be installed such that it is protected from external influences, for example it may be necessary to attach an external strain relief to the cable.

##### Technical data for sensor

Operating voltage  $U_b = 18$  to  $30\text{ V DC}$

Max. load current  $I_a \text{ d" } \ddot{U} 70\text{ mA}$

Ambient temperature:  $-20\text{ °C}$  to  $45\text{ °C}$

##### Commissioning

When connecting the sensor to a power source, please pay attention to the following

- a) the load data (operating voltage, continuous load current)
- b) the wiring diagram for the sensor

##### Maintenance

Our P8S-GPFLX/EX cylinder sensor is maintenance free, but the cable connections should be checked at regular intervals.

The sensor must be protected from UV radiation. The sensor must be kept clean on the outside, and a layer of dirt thicker than 1 mm must never be allowed to form. Strong solvents should not be used for cleaning as they may damage the sensor.

### P8S-GPFLX/EX cylinder sensor



Communauté Européenne = EU



CE on the product shows that Parker Hannifin products meet one or more EU directives.

Ex means that this product is intended for use in potentially explosive atmospheres.

**II**

Stands for the equipment group (I = mines and II = other hazardous areas)

**3G**

Stands for the equipment category 3G means the equipment can be used in zone 2 where there is a risk involving gases, vapours or mists of combustible liquids.

**EEx**

EEx means that this is an electrical product intended for use in Ex-areas.

**nA II**

n Not ignitable to EN50021, A Explosion group tested with acetone, ethanol, toluene and xylene; II Not for use in the mining industry.

**T4 X**

If equipment is in temperature class T4, the maximum surface temperature must not exceed  $135\text{ °C}$ . (To guarantee this, the product has been tested to ensure that the maximum is  $130\text{ °C}$ . This provides a safety margin of  $5\text{ °K}$ .) X Must be installed in accordance with the installation manual.

**3D**

Stands for equipment category 3D in zone 22 where there is a risk involving dusts.

**135 °C**

Maximum permitted surface temperature on the sensor in atmospheres containing potentially explosive dusts.

**IP67**

Satisfies protection class IP67.

### Components such as cylinder attachments, tube fittings, tubes, etc.

#### Components

Parker Hannifin guarantees that our cylinder attachments, tube fittings, tubes, etc. are not subject to the provisions of the ATEX directive.

A component means any item essential to the safe functioning of equipment and protective systems but with no autonomous function.

Components intended for incorporation into equipment or protective systems which are accompanied by an attestation of conformity with the ATEX directive, including a statement of their characteristics and how they must be incorporated into products, are considered to conform to the applicable provisions of directive 94/9/EC. Ex-components as defined in the European standard EN 50014 are components in the sense of the ATEX directive 94/9/EC as well. Components must not have the CE marking affixed unless otherwise required by other directives.

Examples of components:

- terminals
- push buttons assemblies
- relays
- empty flameproof enclosures
- ballasts for fluorescent lamps
- meters (e.g. moving coil)
- encapsulated relays and contactors, with terminals and/or flying leads

**P1D Standard**

**CAD drawings on the Internet**

Our home page [www.parker.com/euro\\_pneumatic](http://www.parker.com/euro_pneumatic) includes the AirCad Drawing Library with 2D and 3D drawings for the main versions.

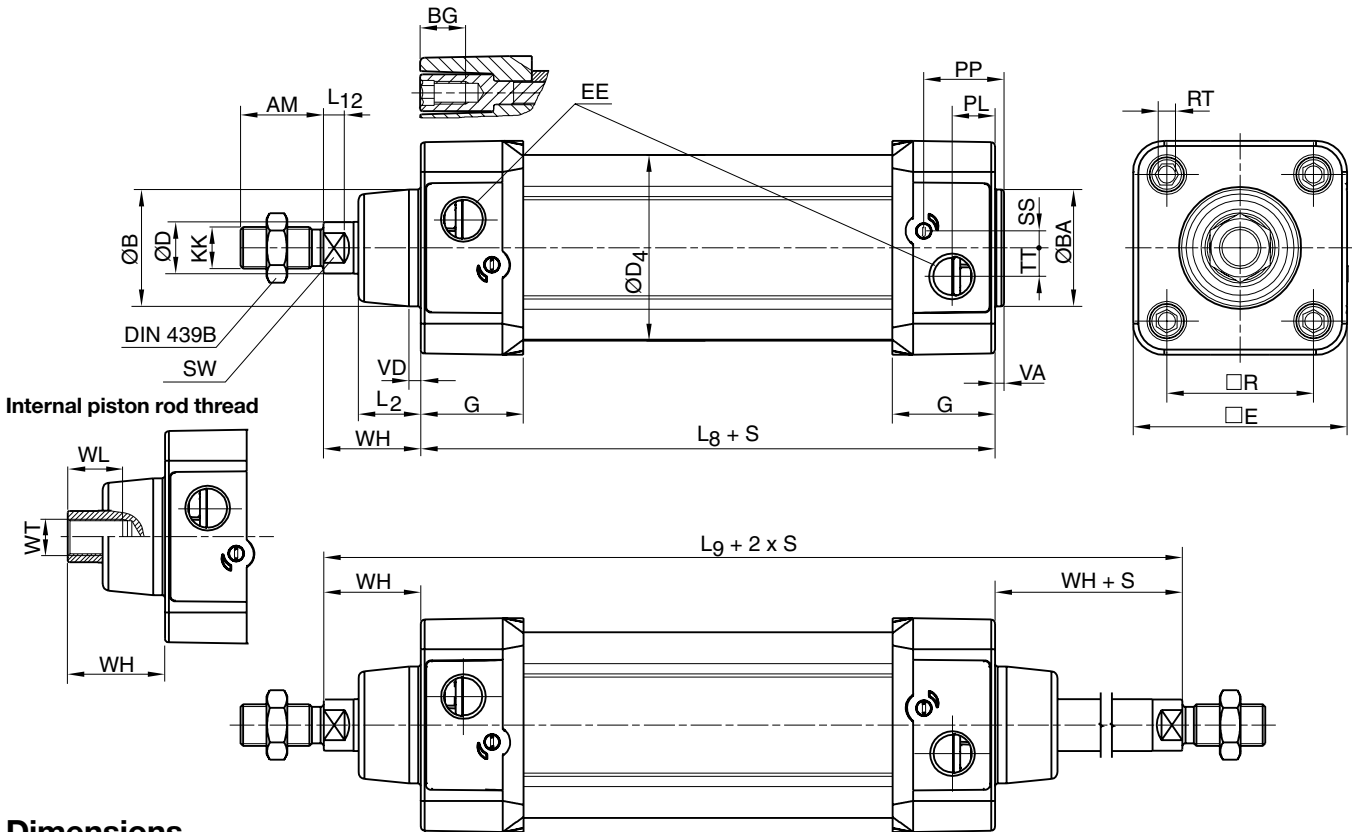

**Dimensions**

Cylinder bore mm	AM mm	B mm	BA mm	BG mm	D mm	D4 mm	E mm	EE mm	G mm	KK	L2 mm	L8 mm	L9 mm	L12 mm
32	22	30	30	16	12	45,0	50,0	G1/8	28,5	M10x1,25	16,0	94	146	6,0
40	24	35	35	16	16	52,0	57,4	G1/4	33,0	M12x1,25	19,0	105	165	6,5
50	32	40	40	16	20	60,7	69,4	G1/4	33,5	M16x1,5	24,0	106	180	8,0
63	32	45	45	16	20	71,5	82,4	G3/8	39,5	M16x1,5	24,0	121	195	8,0
80	40	45	45	17	25	86,7	99,4	G3/8	39,5	M20x1,5	30,0	128	220	10,0
100	40	55	55	17	25	106,7	116,0	G1/2	44,5	M20x1,5	32,4	138	240	14,0
125	54	60	60	20	32	134,0	139,0	G1/2	51,0	M27x2	45,0	160	290	18,0

Cylinder bore mm	PL mm	PP mm	R mm	RT	SS mm	SW mm	TT mm	VA mm	VD mm	WH mm	WL mm	WT
32	13,0	21,8	32,5	M6	4,0	10	4,5	3,5	4,5	26	21	M8x1
40	14,0	21,9	38,0	M6	8,0	13	5,5	3,5	4,5	30	23	M10x1,25
50	14,0	23,0	46,5	M8	4,0	17	7,5	3,5	5,0	37	31	M14x1,5
63	16,4	27,4	56,5	M8	6,5	17	11,0	3,5	5,0	37	31	M14x1,5
80	16,0	30,5	72,0	M10	0	22	15,0	3,5	4,0	46	39	M18x1,5
100	18,0	35,8	89,0	M10	0	22	20,0	3,5	4,0	51	39	M18x1,5
125	28,0	40,5	110,0	M12	0	27	17,5	5,5	6,0	65	53	M24x2

S=Stroke

**Tolerances**

Cylinder bore mm	B	BA	L <sub>3</sub> mm	L <sub>9</sub> mm	R mm	Stroke tolerance up to stroke 500 mm	Stroke tolerance for stroke over 500 mm
32	d11	d11	±0,4	±2	±0,5	+0,3/+2,0	+0,3/+3,0
40	d11	d11	±0,7	±2	±0,5	+0,3/+2,0	+0,3/+3,0
50	d11	d11	±0,7	±2	±0,6	+0,3/+2,0	+0,3/+3,0
63	d11	d11	±0,8	±2	±0,7	+0,3/+2,0	+0,3/+3,0
80	d11	d11	±0,8	±3	±0,7	+0,3/+2,0	+0,3/+3,0
100	d11	d11	±1,0	±3	±0,7	+0,3/+2,0	+0,3/+3,0
125	d11	d11	±1,0	±3	±1,1	+0,3/+2,0	+0,3/+3,0

**P1D Clean**

Minimum stroke for P1D Clean is 25 mm with 0-2 sensors and 100 mm with 3-4 sensors.

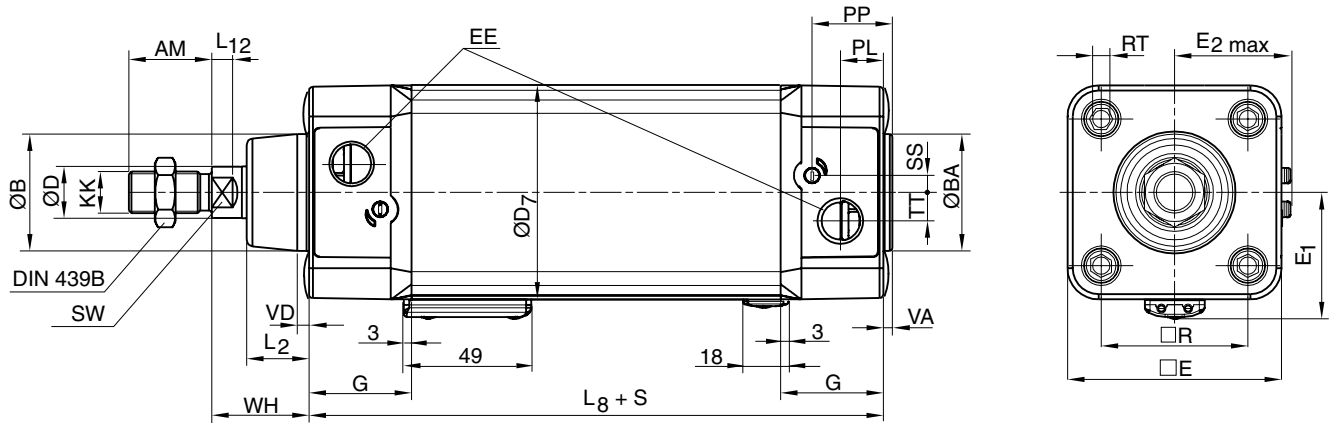

**P1D Tie-Rod**

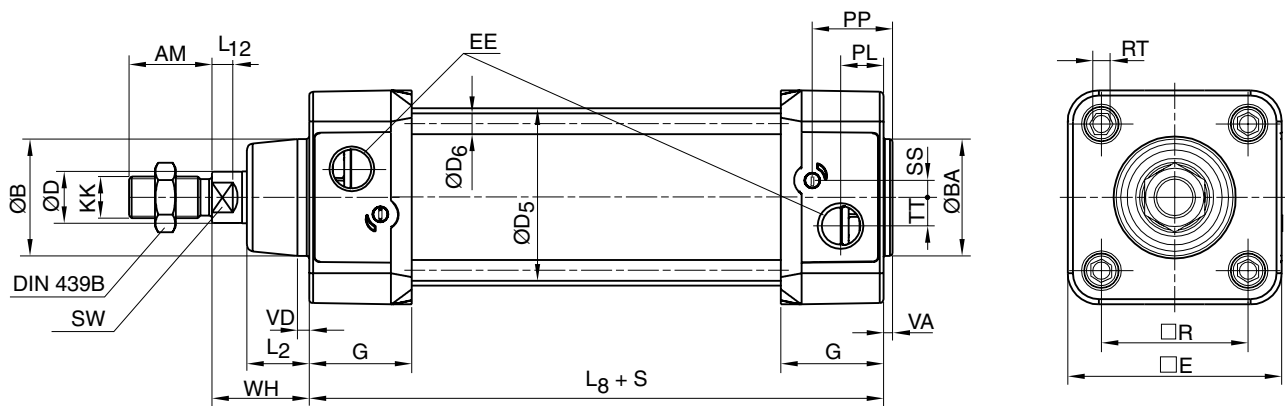

**P1D Flexible Porting**

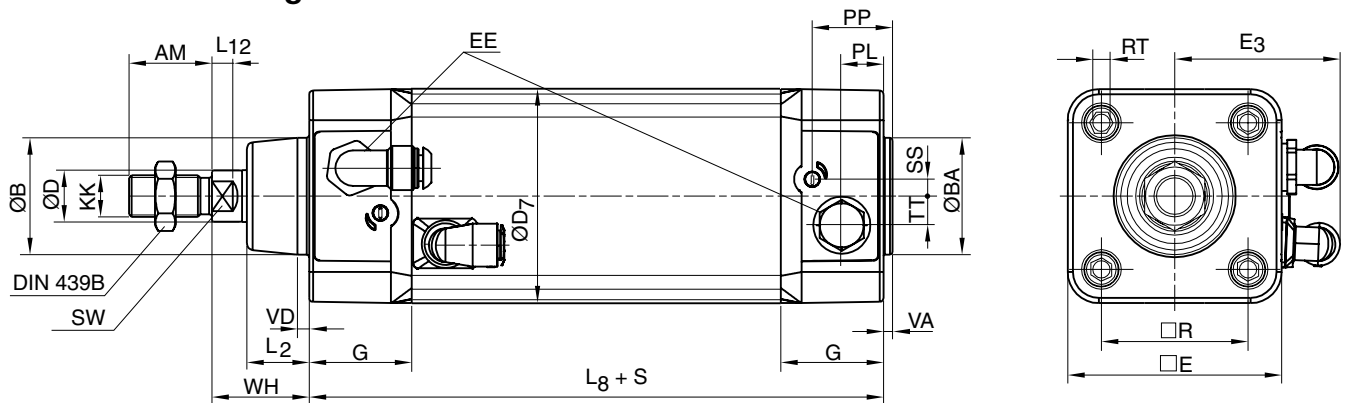

**Dimensions**

Cylinder bore	Cylinder bore					Elbow fittings, tubing Ømm				Straight fittings, tubing Ømm			
	D5	D6	D7	E1	E2max	4	6	8	10	4	6	8	10
mm	mm	mm	mm	mm	mm	E3	E3	E3	E3	E3	E3	E3	E3
32	36	5,3	49,6	32	30,0	42	44	-	-	38	40	-	-
40	44	5,3	57,3	36	34,7	46	48	-	-	42	44	-	-
50	55	7,1	69,3	42	40,7	-	-	56	76	-	-	48	50
63	68	7,1	82,3	49	46,2	-	-	64	83	-	-	55	75
80	86	8,9	99,3	57	54,7	-	-	-	-	-	-	-	-
100	106	8,9	117,6	68	64,0	-	-	-	-	-	-	-	-
125	132	10,8	142,8	81	75,5	-	-	-	-	-	-	-	-

Other dimensions, see opposite page

P1D Flexible Porting Ø80 - Ø125 can be ordered with threaded ports only or with factory-fitted elbow or straight push-in fittings (see position 20 in the order code key page 32)



# P1D Series Pneumatic Cylinders

## The simple and complete order key

The P1D order key is based on the same principles as its predecessors, the P1C and P1E. This makes it easy to identify and order all common cylinder versions. The change-over from our previous cylinder ranges to the equivalent P1D cylinders is logical and simple. As far as possible, the same symbols as for P1C and P1E have been retained for the same functions. Most of the common cylinder types in the P1D-family have a 15-digit order number.

Many of our new cylinder versions, e.g. P1D Clean and P1D Flexible Porting, and complete working units (with factory-fitted cylinder mountings, sensors etc.) are defined by a 20-digit order number. There is only one single order key for P1D, which thus contains the 15-digit order numbers for the most common cylinder types and 20-digit order numbers for cylinders with more functions. Remember that there are always 15 or 20 positions in the order number – never any figure in between.



Valid for P1D-S\*\*\*MS-\*\*\*\*, see ATEX information pages 22 - 25.

1	2	3	4	5	6	7	8	9	10	11	12	13	14	15
<b>P</b>	<b>1</b>	<b>D</b>	<b>-</b>	<b>S</b>	<b>0</b>	<b>3</b>	<b>2</b>	<b>M</b>	<b>S</b>	<b>-</b>	<b>0</b>	<b>1</b>	<b>0</b>	<b>0</b>

Cylinder version	
<b>S</b>	Standard
<b>C</b>	Clean <sup>2)</sup>
<b>F</b>	Flexible Porting
<b>T</b>	Tie-Rod

**Stroke (mm)**  
e.g. **0100** = 100 mm

Optional stroke lengths up to 2800 mm. Standard strokes see table page 18

<b>Cylinder bore mm</b>	<b>End cover screws</b>	<b>Function</b>	<b>Piston rod material</b>	<b>Seals</b>
<b>032</b>	<b>Standard</b>			
<b>040</b>				
<b>050</b>				
<b>063</b>				
<b>080</b>				
<b>100</b>				
<b>125</b>				
	<b>Stainless steel<sup>22)</sup></b>			
	Std scraper		Stainless steel	
	HDPE scraper <sup>23)</sup>		Chromium-plated steel	
	FPM sscraper <sup>24)</sup>		Acid-proof steel	
	Std scraper		Chrom.-pl. stainless steel	
	HDPE scraper <sup>23)</sup>			
	FPM sscraper <sup>24)</sup>			
	<b>M D V A H W</b>	<b>Double-acting</b>	<b>S C M R</b>	<b>Standard -20 °C to +80 °C.</b>
	<b>F E B G Y Z</b>	<b>Double-acting through rod</b>		
	<b>2 6 8 - - -</b>	<b>3 and 4 position cylinders</b>		
	<b>C K L - - -</b>	<b>Tandem</b>		

2) P1D Clean without sensor function, see page 41.

6) For P1D-S and P1D-T.

22) If stainless steel end cover screws are selected, the piston rod nuts are also supplied in stainless steel.

23) For dry rod operation.

24) FPM scraper should be chosen for higher chemical resistance on standard temperature versions only.

### Example 1 Standard, double acting cylinder

Standard cylinder with standard scraper ring (PUR), standard piston rod material (stainless steel) and standard temperature range.

**P1D**

P1D-S032MS-0160

P1D-S100MS-0400

**Compare P1C and P1E**

P1C-S032MS-0160

P1E-S032MS-0160

P1C-S100MS-0400

P1E-S100MS-0400

### Example 2 Tie-Rod design, double acting cylinder

Tie-rod cylinder with standard scraper ring (PUR), hard chromed steel piston rod and standard temperature range.

**P1D**

P1D-T040MC-0125

**Compare P1E**

P1E-T040MC-0125



# P1D Series Pneumatic Cylinders

## P1D Standard

The order numbers on this page refer to P1D Standard without sensors. The cylinders can be ordered with sensors, fittings, piston rod and cylinder mountings, speed controls etc. for efficient logistics. Please refer to the order key to select cylinders with factory-fitted accessories.



**CE Ex II 2GD c T4 120 °C**

See ATEX information pages 22 - 25.

### P1D Standard

Double-acting

Cyl. bore mm	Stroke mm	Order code
<b>32</b> Conn. G1/8	25	P1D-S032MS-0025
	40	P1D-S032MS-0040
	50	P1D-S032MS-0050
	80	P1D-S032MS-0080
	100	P1D-S032MS-0100
	125	P1D-S032MS-0125
	160	P1D-S032MS-0160
	200	P1D-S032MS-0200
	250	P1D-S032MS-0250
	320	P1D-S032MS-0320
	400	P1D-S032MS-0400
500	P1D-S032MS-0500	
<b>40</b> Conn. G1/4	25	P1D-S040MS-0025
	40	P1D-S040MS-0040
	50	P1D-S040MS-0050
	80	P1D-S040MS-0080
	100	P1D-S040MS-0100
	125	P1D-S040MS-0125
	160	P1D-S040MS-0160
	200	P1D-S040MS-0200
	250	P1D-S040MS-0250
	320	P1D-S040MS-0320
	400	P1D-S040MS-0400
500	P1D-S040MS-0500	
<b>50</b> Conn. G1/4	25	P1D-S050MS-0025
	40	P1D-S050MS-0040
	50	P1D-S050MS-0050
	80	P1D-S050MS-0080
	100	P1D-S050MS-0100
	125	P1D-S050MS-0125
	160	P1D-S050MS-0160
	200	P1D-S050MS-0200
	250	P1D-S050MS-0250
	320	P1D-S050MS-0320
	400	P1D-S050MS-0400
500	P1D-S050MS-0500	
<b>63</b> Conn. G3/8	25	P1D-S063MS-0025
	40	P1D-S063MS-0040
	50	P1D-S063MS-0050
	80	P1D-S063MS-0080
	100	P1D-S063MS-0100
	125	P1D-S063MS-0125
	160	P1D-S063MS-0160
	200	P1D-S063MS-0200
	250	P1D-S063MS-0250
	320	P1D-S063MS-0320
	400	P1D-S063MS-0400
500	P1D-S063MS-0500	

### P1D Standard

Double-acting

Cyl. bore mm	Stroke mm	Order code
<b>80</b> Conn. G3/8	25	P1D-S080MS-0025
	40	P1D-S080MS-0040
	50	P1D-S080MS-0050
	80	P1D-S080MS-0080
	100	P1D-S080MS-0100
	125	P1D-S080MS-0125
	160	P1D-S080MS-0160
	200	P1D-S080MS-0200
	250	P1D-S080MS-0250
	320	P1D-S080MS-0320
	400	P1D-S080MS-0400
500	P1D-S080MS-0500	
<b>100</b> Conn. G1/2	25	P1D-S100MS-0025
	40	P1D-S100MS-0040
	50	P1D-S100MS-0050
	80	P1D-S100MS-0080
	100	P1D-S100MS-0100
	125	P1D-S100MS-0125
	160	P1D-S100MS-0160
	200	P1D-S100MS-0200
	250	P1D-S100MS-0250
	320	P1D-S100MS-0320
	400	P1D-S100MS-0400
500	P1D-S100MS-0500	
<b>125</b> Conn. G1/2	25	P1D-S125MS-0025
	40	P1D-S125MS-0040
	50	P1D-S125MS-0050
	80	P1D-S125MS-0080
	100	P1D-S125MS-0100
	125	P1D-S125MS-0125
	160	P1D-S125MS-0160
	200	P1D-S125MS-0200
	250	P1D-S125MS-0250
	320	P1D-S125MS-0320
	400	P1D-S125MS-0400
500	P1D-S125MS-0500	

The cylinders are supplied complete with one zinc plated steel piston rod nut.

## P1D Series Pneumatic Cylinders

### P1D cylinders with piston rod mountings and end cover screw sealing plugs

Using the 20-digit order number, it is possible to order complete working units with factory installed piston rods and cylinder mountings, sensors etc.

Piston rod mountings and sealing plugs for the cylinder end cover screws are specified in position 16 in accordance with the order key below.

Please note that an order code with sealing plugs must be combined with selecting a cylinder mounting in position 17. The sealing plugs are installed in the end cover screws which are not used.

1	2	3	4	5	6	7	8	9	10	11	12	13	14	15	16	17	18	19	20
P	1	D	-	S	0	4	0	M	S	-	0	3	2	0	C	N	N	N	N

Factory-fitted piston rod mountings and sealing plugs			
	No plugs	With plugs <sup>8)</sup>	
	S	A	Swivel rod eye, zinc-plated steel
	T	1	Swivel rod eye, stainless steel <sup>10)</sup>
	V	E	Swivel rod eye, zinc-plated steel and clevis bracket GA
	W	2	Swivel rod eye, stainless steel and clevis bracket GA <sup>10)</sup>
	C	B	Clevis, zinc-plated steel
	D	3	Clevis, stainless steel <sup>10)</sup>
	F	G	Flexo coupling, zinc-plated steel
	X	P	One additional piston rod nut <sup>9)</sup>
	Y	4	Piston rod nut in stainless steel <sup>10)</sup>
	Z	5	Piston rod nut in acid-proof steel
	6	7	Without piston rod nut
	H	L	Rod guidance module, H style, ball bearings <sup>18)</sup>
	J	M	Rod guidance module, H style, plain bearings <sup>18)</sup>
	K	Q	Rod guidance module, U style, plain bearings <sup>18)</sup>
	N	R	None

8) Valid only for cylinders with factory-fitted cylinder mountings. P1D Clean cylinders are always delivered with 4 sealing plugs.

9) P1D cylinders are always delivered with one piston rod nut in zinc-plated steel, except P1D Clean which is delivered with the piston rod nut in stainless steel. Codes X and P mean that the cylinder is delivered with one additional nut of the same type.

10) The piston rod nut in zinc-plated steel is replaced by a nut in stainless steel (P1D Clean is always delivered with one piston rod nut in stainless steel).

18) Only for bore 32-100 mm

#### Example of piston rod fittings and end cover screw sealing plugs

P1D-S040MS-0320CNNNN P1D Standard with a zinc plated clevis on the piston rod and without sealing plugs in the end cover screws

P1D-S080MS-0250ATNNN P1D Standard with swivel rod eye on the piston rod, clevis bracket MP2 installed on rear end cover and sealing plugs in the cylinder end cover screws in the front end.

**P1D cylinders with centre trunnion and cylinder mountings**

There are three different types of centre trunnion in the P1D family. A centre trunnion for the P1D Standard and one for the P1D Tie-Rod placed in the centre or an optional location of the cylinder, or a flange mounted centre trunnion on the front or rear end cover that fits all P1D cylinders.

For the P1D, the centre trunnion is available among the cylinder mountings in position 17. If G or 7 appears in position 17, the position of the centre trunnion should be specified as a three-digit measurement in positions 18-20. For P1D-S, 000 indicates a loose centre trunnion. If D or 6 appears in position 17, the centre trunnion is always centred on the cylinder (no

measurement specified in positions 18-20). For some of our previous cylinder series, the centre trunnion is selected back in position 5, e.g. P1C-C. Remember that C in position 5 for P1D means the Clean cylinder version and nothing else!

It is possible to equip the cylinders with factory installed piston rod mountings, sensors, fittings etc. in the usual way. For the version with optional location of the centre trunnion or loose centre trunnion, no choices can be made for positions 18-20 since they are used for the XV dimension. (See page 60)

1	2	3	4	5	6	7	8	9	10	11	12	13	14	15	16	17	18	19	20
P	1	D	-	T	0	4	0	M	S	-	0	3	2	0	N	D	N	N	N

Cylinder version	
S	Standard
C	Clean <sup>2)</sup>
F	Flexible Porting
T	Tie-Rod

Cylinder mountings		
90°	0°	90° = shaft square to, 0° = shaft in line with ports <sup>5)</sup>
1	3	Flange MF1/MF2 in front end
B	4	Flange MF1/MF2 in rear end
2	K	Flange MF1/MF2 in both ends
F	-	Foot brackets MS1 (both ends)
C	U	Clevis bracket GA
E	V	Clevis bracket MP4
S	W	Swivel eye bracket
T	Y	Clevis bracket MP2
L	Z	Clevis bracket MP2+MP4
X	5	Clevis bracket MP2+pivot bracket with rigid bearing
Q	0	Clevis bracket GA + pivot bracket with swivel bearing
M	A	Clevis bracket GA +swivel eye bracket
D	6	Centre trunnion MT4, mid position <sup>6)</sup>
G	7	Trunnion MT4, optional pos. (XV-meas. pos 18-20) <sup>7)</sup>
H	P	Trunnion flange in front end
J	8	Trunnion flange in rear end
N		None

- 2) P1D Clean without sensor function, see page 41.
- 5) Shaft or pivots square to or in line with the cylinder ports.
- 6) For versions P1D-S and P1D-T
- 7) For P1D-S and P1D-T, XV-measure (from the piston rod thread according to ISO to the centre of the pivots) stated in mm in positions 18-20 (max 999, or 000 if loose centre trunnion specified). For XV measures, see page 60.

**Examples of centre trunnion**

- P1D-S050MS-0250NDNNN      P1D Standard rod cylinder with centre trunnion installed in centre of cylinder.
- P1D-T050MS-0250NG205      P1D Tie rod cylinder with centre trunnion installed on XV dimension specified in positions 18,19 and 20.
- P1D-S032MS-0160NHNNN      P1D Standard cylinder with trunnion flange mounted on front end cover.
- P1D-S032MS-0160NJNNN      P1D Standard cylinder with trunnion flange mounted on rear end cover.

**Examples of other combinations**

- P1D-C050MS-02501HQN6      P1D Clean cylinder with trunnion flange mounted on front end cover, two reed sensors, 8 mm connector (1 m cable), cable connection on rear end cover, factory installed stainless steel swivel rod eye, push-in fittings (Prestolok, nickel plated brass) low elbow type for 6 mm tube, sealing plugs installed in unused end cover screws (code 1 for stainless swivel rod eye).
- P1D-F080MSJ0400XJFN0      P1D Flexible Porting cylinder with trunnion flange mounted on rear end cover, two threaded connections in rear end cover, extra zinc plated steel piston rod nut (i.e. a total of two zinc plated steel nuts), two factory installed electronic sensors, 24 VDC, PNP type, 3 m cable, factory installed push-in fittings (Prestolok, nickel plated brass) low elbow type for 10 mm tube.

# P1D Series Pneumatic Cylinders

## Factory-fitted sensors

All P1D cylinders can be supplied with up to four factory installed sensors (standard reed or electronic sensors) in specially designed grooves. Both cable and sensor are protected in the groove. Choose a sensor with 3 or 10 m cable or with 8 mm connector.

P1D Clean has a system of sensors fully integrated in the body extrusion, in specially designed grooves underneath a transparent, sealed moulding. The factory installed sensors are

installed at the end positions and can then easily be moved anywhere along the entire stroke during commissioning. The sensors can be ordered with cable exit in the front end cover, rear end cover or at both end covers.

For cylinders with 3 sensors, 2 sensors are installed in the rear end position and one sensor in the front end position.

Cylinders with 4 sensors are supplied with 2 sensors in each end position.

1	2	3	4	5	6	7	8	9	10	11	12	13	14	15	16	17	18	19	20
P	1	D	-	S	0	5	0	M	S	-	0	3	2	0	N	N	C	N	N

Factory-fitted sensors			
Front end or left <sup>1)</sup>	Rear end or right <sup>1)</sup>	Front and rear end	Cable exit
<b>F</b>	<b>R</b>	-	2 sensors 24 VDC pnp, 3 m cable
<b>G</b>	<b>H</b>	-	2 sensors 24 VDC pnp, 10 m cable
<b>C</b>	<b>S</b>	-	2 sensors 24 VDC pnp, 8 mm connector <sup>2)</sup>
<b>K</b>	<b>L</b>	-	2 sensors Reed type, 3 m cable
<b>T</b>	<b>V</b>	-	2 sensors Reed type, 10 m cable
<b>M</b>	<b>Q</b>	-	2 sensors Reed type, 8 mm connector <sup>2)</sup>
-	-	<b>3</b>	3 sensors 24 VDC pnp, 8 mm connector <sup>2)</sup>
-	-	<b>Z</b>	3 sensors Reed type, 8 mm connector <sup>2)</sup>
-	-	<b>4</b>	4 sensors 24 VDC pnp, 8 mm connector <sup>2)</sup>
-	-	<b>W</b>	4 sensors Reed type, 8 mm connector <sup>2)</sup>
<b>6</b> <sup>12)</sup>	<b>7</b> <sup>13)</sup>	<b>8</b> <sup>14)</sup>	No factory-fitted sensors P1D Clean
<b>N</b>			No sensors P1D (excl. P1D Clean)

11) Left and right valid for P1D Standard and P1D Tie-Rod seen from behind with the ports on top. The sensors can only be mounted on the left for P1D Flexible Porting.

12) No factory-fitted sensors, but prepared for cable exit in the front end (max. 2 sensors).

13) No factory-fitted sensors, but prepared for cable exit in the rear end (max. 2 sensors).

14) No factory-fitted sensors, but prepared for cable exit in both ends (max. 4 sensors).

21) The standard cable length is 0.27 m. However, P1D Clean is supplied with 1 m cable length.

Depending on the location of the sensors, the cable length (1 m) may limit the stroke of the P1D Clean cylinder

### Example of sensors

P1D-S050MS-0320NNCNCN P1D Standard with two factory installed sensors 24 VDC PNP, 8 mm connector

P1D-C063MS-0250NNLNN P1D Clean with two factory installed Reed sensors, 3 m cable and cable connection at rear end cover on left side

P1D-F080MS-0400NNMNN P1D Flexible Porting with two factory installed Reed sensors, 8 mm connector

# P1D Series Pneumatic Cylinders

## Pre-assembled fittings or speed controls

All P1D cylinders can be delivered with elbow or straight push-in fittings in nickel-plated brass (Prestolok) or speed controls in brass (series PTF). P1D Clean cylinders are factory-fitted nickel-plated versions of the PTF speed controls. Please see page 42 for the order code key for P1D Flexible Porting with pre-assembled fittings.

1	2	3	4	5	6	7	8	9	10	11	12	13	14	15	16	17	18	19	20	
<b>P</b>	<b>1</b>	<b>D</b>	<b>-</b>	<b>S</b>	<b>0</b>	<b>5</b>	<b>0</b>	<b>M</b>	<b>S</b>	<b>-</b>	<b>0</b>	<b>3</b>	<b>2</b>	<b>0</b>	<b>N</b>	<b>N</b>	<b>N</b>	<b>N</b>	<b>N</b>	<b>8</b>

Speed controls or fittings for tube dimension	
<b>Speed controls<sup>17)</sup> Series PTF 4PB<sup>16)</sup></b>	
<b>X</b>	in both ends for tube 4 mm
<b>Y</b>	in both ends for tube 6 mm
<b>Z</b>	in both ends for tube 8 mm
<b>P</b>	in both ends for tube 10 mm
<b>R</b>	in both ends for tube 12 mm
Push-in fitting, elbow type for:	
<b>4</b>	Tube dimension 4 mm
<b>6</b>	Tube dimension 6 mm
<b>8</b>	Tube dimension 8 mm
<b>0</b>	Tube dimension 10 mm
<b>2</b>	Tube dimension 12 mm
Push-in fitting, straight type for:	
<b>1</b>	Tube dimension 4 mm
<b>3</b>	Tube dimension 6 mm
<b>5</b>	Tube dimension 8 mm
<b>7</b>	Tube dimension 10 mm
<b>9</b>	Tube dimension 12 mm
<b>N</b>	None

Available fittings and speed controls for P1D Standard			
Cyl. bore	Speed controls for tube	Elbow fitting for tube	Straight fitting for tube
<b>32</b>	4, 6, 8	4, 6, 8	4, 6, 8
<b>40, 50</b>	6, 8	4, 6, 8, 10, 12	4, 6, 8, 10, 12
<b>63, 80</b>	8, 10, 12	8, 10, 12	8, 10, 12
<b>100, 125</b>	12	12	10, 12

16) P1D Clean cylinders have factory fitted nickel plated versions of the PTF series.

17) Not available for P1D Flexible Porting bore 32-63 mm.

### Example P1D Standard with factory-fitted fittings or speed controls

P1D-S050MS-0320NNNN8 P1D Standard cylinder with two push-in fittings, elbow type for 8 mm tube.

P1D-S125MS-0400NNNNR P1D Standard cylinder with two speed controls for 12 mm tube.



# P1D Series Pneumatic Cylinders

## Extended piston rod

All cylinders in the P1D family can be ordered with extended piston rod, for all piston rod materials. To make it possible to combine piston rod extension with all the functions and properties in the P1D system, the three positions which normally

specify cylinder bore are used to specify both bore and extension. When ordering a P1D cylinder with extended piston rod, specify this as below.

1	2	3	4	5	6	7	8	9	10	11	12	13	14	15
<b>P</b>	<b>1</b>	<b>D</b>	-	<b>S</b>	<b>K</b>	<b>R</b>	<b>5</b>	<b>M</b>	<b>S</b>	-	<b>0</b>	<b>3</b>	<b>2</b>	<b>0</b>

Cylinder bore mm	
<b>K</b>	32
<b>L</b>	40
<b>M</b>	50
<b>N</b>	63
<b>P</b>	80
<b>Q</b>	100
<b>R</b>	125

Piston rod extension			
E.g. KR5 = Cylinder bore 32 mm with piston rod extension = 255 mm			
<b>O1-O9</b>	1-99	<b>N0-N9</b>	220-229
<b>A0-A9</b>	100-109	<b>P0-P9</b>	230-239
<b>B0-B9</b>	110-119	<b>Q0-Q9</b>	240-249
<b>C0-C9</b>	120-129	<b>R0-R9</b>	250-259
<b>D0-D9</b>	130-139	<b>S0-S9</b>	260-269
<b>E0-E9</b>	140-149	<b>T0-T9</b>	270-279
<b>F0-F9</b>	150-159	<b>U0-U9</b>	280-289
<b>G0-G9</b>	160-169	<b>V0-V9</b>	290-299
<b>H0-H9</b>	170-179	<b>W0-W9</b>	300-309
<b>J0-J9</b>	180-189	<b>X0-X9</b>	310-319
<b>K0-K9</b>	190-199	<b>Y0-Y9</b>	320-329
<b>L0-L9</b>	200-209	<b>Z0-Z9</b>	330-339
<b>M0-M9</b>	210-219		

The maximum extended piston rod length that can be specified by the order key is 339 mm. If a longer extended piston rod is needed please contact us and we will organise a special part number.

By changing from 032 to KR5, the cylinder has been given a 255 mm extended piston rod. At the same time, the cylinder can be specified with all functions and properties in the other positions.

### Example of an extended piston rod

- P1D-SK45MS-0200      P1D Standard cylinder, bore 32 mm, with a 45 mm extended piston rod.
- P1D-TPD2MS-0500      P1D Tie-Rod cylinder, bore 80 mm, with 132 mm extended piston rod.

## Piston rod in alternative materials

P1D has a polished stainless steel piston rod as standard. If you want a different material and/or surface treatment, please order this in combination with seal material in position 10.

Piston rod nuts are supplied in zinc plated steel as standard, but stainless steel piston rod nuts are always supplied for P1D Clean. If an alternative material is used, the piston rod nut is always supplied in the same material.

1	2	3	4	5	6	7	8	9	10	11	12	13	14	15
<b>P</b>	<b>1</b>	<b>D</b>	-	<b>S</b>	<b>0</b>	<b>3</b>	<b>2</b>	<b>M</b>	<b>S</b>	-	<b>0</b>	<b>1</b>	<b>0</b>	<b>0</b>

Piston rod material				Seals
Stainless steel	Chromium-plated steel	Acid-proof steel	Chrom.-pl. stainless steel	
<b>S</b>	<b>C</b>	<b>M</b>	<b>R</b>	Standard -20 °C to +80 °C.

### Example of piston rod material

- P1D-S032MS-0100      P1D Standard cylinder, bore 32 mm, with stainless steel piston rod (standard)
- P1D-T040MC-0160      P1D Tie-Rod cylinder, bore 40 mm, with hard chromed steel piston rod

# P1D Series Pneumatic Cylinders

## Through piston rod

All P1D cylinders can be ordered with a through piston rod. Order this design in position 9 in combination with the scraper ring system as below.

1	2	3	4	5	6	7	8	9	10	11	12	13	14	15
P	1	D	-	S	0	3	2	F	S	-	0	1	0	0

End cover screws								Function
Standard				Stainless steel <sup>22)</sup>				
Std scraper	Metal scraper <sup>25)</sup>	HDPE scraper <sup>23)</sup>	FPM scraper <sup>26)</sup>	Std scraper	Metal scraper <sup>25)</sup>	HDPE scraper <sup>23)</sup>	FPM scraper <sup>26)</sup>	
M	Q	D	V	A	S	H	W	Double-acting
F	R	E	B	G	T	Y	Z	Double-acting through rod

22) If stainless steel end cover screws are selected, the piston rod nuts are also supplied in stainless steel.

23) For dry rod operation.

25) The metal scraper ring requires a hard-chromium plated piston rod

26) FPM scraper should be chosen for higher chemical resistance on standard temperature versions only.

### Example of through piston rod

P1D-S032FS-0100                      P1D Standard cylinder, bore 32 mm, with through piston rod  
 P1D-T050FS-0125                      P1D Tie-Rod cylinder, bore 50 mm, with through piston rod

## 3 and 4 position cylinders

Factory-fitted 3 and 4 position cylinders can be ordered in tie-rod design P1D-T. Through going tie-rods fix the two cylinders into a compact unit.

1	2	3	4	5	6	7	8	9	10	11	12	13	14	15	16	17	18	19	20
P	1	D	-	T	0	8	0	2	S	-	0	2	0	0	N	0	2	5	0

Cylinder version		End cover screws								Function
		Standard				Stainless steel <sup>22)</sup>				
S	Standard	Std scraper	Metal scraper <sup>25)</sup>	HDPE scraper <sup>23)</sup>	FPM scraper <sup>26)</sup>	Std scraper	Metal scraper <sup>25)</sup>	HDPE scraper <sup>23)</sup>	FPM scraper <sup>26)</sup>	
C	Clean									
F	Flexible Porting									
T	Tie-Rod	2	4	6	8	-	-	-	-	3 and 4 position cylinders
C		J	K	L	-	-	-	-	-	Tandem

22) If stainless steel end cover screws are selected, the piston rod nuts are also supplied in stainless steel.

23) For dry rod operation.

25) The metal scraper ring requires a hard-chromium plated piston rod

26) FPM scraper should be chosen for higher chemical resistance on standard temperature versions only.

### Equal stroke – 3 position cylinder

Specify letter T in position 5 (P1D-T) and figure 2 in position 9 (standard scraper ring)

### Unequal stroke – 4 position cylinder

Specify letter T in position 5 (P1D-T) and figure 2 in position 9 (standard scraper ring)  
 Specify the shortest stroke in the ordinary positions 12, 13, 14, 15 and the longest stroke in positions 17, 18, 19, 20.

### Example of 3 and 4 position cylinders

P1D-T0322S-0200SNNN4    P1D Tie-Rod cylinder with 3 position design, swivel rod eye in zinc plated steel, factory installed plug-in fittings (Prestolok, nickel plated brass) for 4 mm tube.

P1D-T0632S-0160            P1D Tie-Rod cylinder with 3 position design

P1D-T0802S-0200N0250    P1D Tie-Rod cylinder with 4 position design with stroke 200 mm and 250 mm.



# P1D Series Pneumatic Cylinders

## Tandem cylinders

The P1D-T is available in tandem design i.e. two cylinders in series, for almost double force. Order with the letter C in position 9.

1	2	3	4	5	6	7	8	9	10	11	12	13	14	15
<b>P</b>	<b>1</b>	<b>D</b>	<b>-</b>	<b>T</b>	<b>0</b>	<b>4</b>	<b>0</b>	<b>C</b>	<b>S</b>	<b>-</b>	<b>0</b>	<b>3</b>	<b>2</b>	<b>0</b>

End cover screws								Function
Standard				Stainless steel <sup>22)</sup>				
Std scraper	Metal scraper <sup>25)</sup>	HDPE scraper <sup>23)</sup>	FPM sscraper <sup>26)</sup>	Std scraper	Metal scraper <sup>25)</sup>	HDPE scraper <sup>23)</sup>	FPM sscraper <sup>26)</sup>	
<b>M</b>	<b>Q</b>	<b>D</b>	<b>V</b>	<b>A</b>	<b>S</b>	<b>H</b>	<b>W</b>	Double-acting
<b>F</b>	<b>R</b>	<b>E</b>	<b>B</b>	<b>G</b>	<b>T</b>	<b>Y</b>	<b>Z</b>	Double-acting through rod
<b>2</b>	<b>4</b>	<b>6</b>	<b>8</b>	-	-	-	-	3 and 4 position cylinders
<b>C</b>	<b>J</b>	<b>K</b>	<b>L</b>	-	-	-	-	Tandem

22) If stainless steel end cover screws are selected, the piston rod nuts are also supplied in stainless steel.

23) For dry rod operation.

25) The metal scraper ring requires a hard-chromium plated piston rod

26) FPM scraper should be chosen for higher chemical resistance on standard temperature versions only.

## Operation with a dry piston rod

The seal system for operation with a dry piston rod (HDPE scraper) is available as an option for all P1D cylinders except high and low temperature version and the hydraulic model.

Order this function by specifying letter D in position 9 (double acting cylinder) or E (double acting cylinder with through piston rod). Specify the code for the seal system in either the 15 or 20 digit part number.

1	2	3	4	5	6	7	8	9	10	11	12	13	14	15
<b>P</b>	<b>1</b>	<b>D</b>	<b>-</b>	<b>S</b>	<b>0</b>	<b>8</b>	<b>0</b>	<b>D</b>	<b>S</b>	<b>-</b>	<b>0</b>	<b>2</b>	<b>0</b>	<b>0</b>

Cylinder version		End cover screws								Function
		Standard				Stainless steel <sup>22)</sup>				
<b>S</b>	Standard	Std scraper	Metal scraper <sup>25)</sup>	HDPE scraper <sup>23)</sup>	FPM sscraper <sup>26)</sup>	Std scraper	Metal scraper <sup>25)</sup>	HDPE scraper <sup>23)</sup>	FPM sscraper <sup>26)</sup>	
<b>C</b>	Clean	<b>M</b>	<b>Q</b>	<b>D</b>	<b>V</b>	<b>A</b>	<b>S</b>	<b>H</b>	<b>W</b>	Double-acting
<b>F</b>	Flexible Porting	<b>F</b>	<b>R</b>	<b>E</b>	<b>B</b>	<b>G</b>	<b>T</b>	<b>Y</b>	<b>Z</b>	Double-acting through rod
<b>T</b>	Tie-Rod	<b>2</b>	<b>4</b>	<b>6</b>	<b>8</b>	-	-	-	-	3 and 4 position cylinders
		<b>C</b>	<b>J</b>	<b>K</b>	<b>L</b>	-	-	-	-	Tandem

22) If stainless steel end cover screws are selected, the piston rod nuts are also supplied in stainless steel.

23) For dry rod operation.

25) The metal scraper ring requires a hard-chromium plated piston rod

26) FPM scraper should be chosen for higher chemical resistance on standard temperature versions only.

### Example of seal system for dry rod

- P1D-S040DS-0200 P1D Standard cylinder with seal system for dry operation.
- P1D-C050DS-0250TERN6 P1D Clean cylinder with seal system for dry operation, stainless steel swivel rod eye, clevis bracket MP4, two factory-fitted electronic sensors, 24 VDC, PNP type, 3 m cable, cable exit at rear end cover, factory-fitted push-in fittings (Prestolok, nickel plated brass) of low elbow type for 6 mm tube. Four sealing plugs for unused end cover screws are enclosed.
- P1D-C063DSC0320DMSN6 P1D Clean cylinder with seal system for dry operation, two push-in low elbow fittings placed at rear end cover for 6 mm tube, stainless steel clevis, combination of clevis bracket GA + swivel eye bracket installed on rear end cover, two factory-fitted electronic sensors, 24 VDC, PNP type, 8 mm connector (1 m cable), cable exit at rear end cover. Four sealing plugs for unused end cover screws are enclosed.

# P1D Series Pneumatic Cylinders

## P1D Clean with built-in sensor

The entirely new P1D Clean with built-in sensors has a 20-digit part number to define all functions. Cylinder version P1D Clean is selected by putting the letter C in position 5 and the sensors are selected in position 18. These two positions determine the design of each P1D Clean cylinder. If required, the piston rod

and cylinder mountings, piston rod thread and fittings or speed controls can be selected in positions 16, 17, 19 and 20 to obtain a complete working unit. You can also specify the code for none of these options. But please remember that a code must be specified in all positions 16 – 20.

1	2	3	4	5	6	7	8	9	10	11	12	13	14	15	16	17	18	19	20
P	1	D	-	C	0	5	0	M	S	-	0	3	2	0	N	N	C	N	N

<b>Cylinder version</b>			
S	Standard		
C	Clean <sup>2)</sup>		
F	Flexible Porting		
T	Tie-Rod		

<b>Factory-fitted sensors, P1D Clean</b>			
Front end or left <sup>11)</sup>	Rear end or right <sup>11)</sup>	Front and rear end	<b>Cable exit</b>
F	R	-	2 sensors 24 VDC PNP, 3 m cable
G	H	-	2 sensors 24 VDC PNP, 10 m cable
C	S	-	2 sensors 24 VDC PNP, 8 mm connector, 1 m cable <sup>21)</sup>
K	L	-	2 sensors Reed type, 3 m cable
T	V	-	2 sensors Reed type, 10 m cable
M	Q	-	2 sensors Reed type, 8 mm connector, 1 m cable <sup>21)</sup>
-	-	3	3 sensors 24 VDC PNP, 8 mm connector, 1 m cable <sup>21)</sup>
-	-	Z	3 sensors Reed type, 8 mm connector, 1 m cable <sup>21)</sup>
-	-	4	4 sensors 24 VDC PNP, 8 mm connector, 1 m cable <sup>21)</sup>
-	-	W	4 sensors Reed type, 8 mm connector, 1 m cable <sup>21)</sup>
6 <sup>12)</sup>	7 <sup>13)</sup>	8 <sup>14)</sup>	No factory-fitted sensors P1D Clean
N			No sensors P1D (excl. P1D Clean)

2) P1D Clean without sensor function, see page 41.

11) Left and right valid for P1D Standard and P1D Tie-Rod seen from behind with the ports on top. The sensors can only be mounted on the left for P1D Flexible Porting.

12) No factory-fitted sensors, but prepared for cable exit in the front end (max. 2 sensors).

13) No factory-fitted sensors, but prepared for cable exit in the rear end (max. 2 sensors).

14) No factory-fitted sensors, but prepared for cable exit in both ends (max. 4 sensors).

21) Due to the sensor positions, the cable length (1 m) could limit the stroke of the P1D Clean cylinders.

### Example of P1D Clean

P1D-C032MS-0200NNCNCN P1D Clean cylinder with two electronic sensors, PNP type, with 8 mm connector, cable exit at front end cover, 4 sealing plugs for end cover screws are enclosed.

P1D-C050MS-0160TNHNN P1D Clean cylinder with two electronic sensors, PNP type, with 10 m cable, cable exit at rear end cover, swivel rod eye in stainless steel, 4 sealing plugs for end cover screws are enclosed.

P1D-C080MS-0250-3BMNNP1D Clean cylinder with two reed sensors, with 8 mm connector, cable connection at front end cover, stainless steel clevis, flange on rear end cover, sealing plugs installed in unused end cover screws.

P1D-C125MS-04004T3NN P1D Clean cylinder with three electronic sensors, PNP type, with 8 mm connector, cable exit at both front and rear end cover (1 cable front, 2 cables rear – can be moved to inverted configuration), extra stainless steel piston rod nut, clevis bracket MP2 on rear end cover, plugs installed in unused end cover screws.

P1D-C040MS-0320RHWN P1D Clean cylinder with four electronic sensors, PNP type, with 8 mm connector, cable exit at both front and rear end cover (2 cables in each end cover), flange mounted trunnion on front end cover, sealing plugs installed in unused end cover screws.

# P1D Series Pneumatic Cylinders

## P1D Clean

The order numbers on this page refer to P1D Clean with two built-in electronic sensors, factory-fitted in the cylinder end positions, with cable exit at the front end cover. See the order code key to select other sensors and other location of the cable exit.



## P1D Clean with electronic sensors 24 VDC, PNP, 1 m cable with 8 mm connector

Double acting

Cyl. bore mm	Stroke mm	Order code
<b>32</b> Conn. G1/8	25	P1D-C032MS-0025NNCNN
	40	P1D-C032MS-0040NNCNN
	50	P1D-C032MS-0050NNCNN
	80	P1D-C032MS-0080NNCNN
	100	P1D-C032MS-0100NNCNN
	125	P1D-C032MS-0125NNCNN
	160	P1D-C032MS-0160NNCNN
	200	P1D-C032MS-0200NNCNN
	250	P1D-C032MS-0250NNCNN
	320	P1D-C032MS-0320NNCNN
<b>40</b> Conn. G1/4	25	P1D-C040MS-0025NNCNN
	40	P1D-C040MS-0040NNCNN
	50	P1D-C040MS-0050NNCNN
	80	P1D-C040MS-0080NNCNN
	100	P1D-C040MS-0100NNCNN
	125	P1D-C040MS-0125NNCNN
	160	P1D-C040MS-0160NNCNN
	200	P1D-C040MS-0200NNCNN
	250	P1D-C040MS-0250NNCNN
	320	P1D-C040MS-0320NNCNN
<b>50</b> Conn. G1/4	25	P1D-C050MS-0025NNCNN
	40	P1D-C050MS-0040NNCNN
	50	P1D-C050MS-0050NNCNN
	80	P1D-C050MS-0080NNCNN
	100	P1D-C050MS-0100NNCNN
	125	P1D-C050MS-0125NNCNN
	160	P1D-C050MS-0160NNCNN
	200	P1D-C050MS-0200NNCNN
	250	P1D-C050MS-0250NNCNN
	320	P1D-C050MS-0320NNCNN
<b>63</b> Conn. G3/8	25	P1D-C063MS-0025NNCNN
	40	P1D-C063MS-0040NNCNN
	50	P1D-C063MS-0050NNCNN
	80	P1D-C063MS-0080NNCNN
	100	P1D-C063MS-0100NNCNN
	125	P1D-C063MS-0125NNCNN
	160	P1D-C063MS-0160NNCNN
	200	P1D-C063MS-0200NNCNN
	250	P1D-C063MS-0250NNCNN
	320	P1D-C063MS-0320NNCNN

Cyl. bore mm	Stroke mm	Order code
<b>80</b> Conn. G3/8	25	P1D-S080MS-0025NNCNN
	40	P1D-C080MS-0040NNCNN
	50	P1D-C080MS-0050NNCNN
	80	P1D-C080MS-0080NNCNN
	100	P1D-C080MS-0100NNCNN
	125	P1D-C080MS-0125NNCNN
	160	P1D-C080MS-0160NNCNN
	200	P1D-C080MS-0200NNCNN
	250	P1D-C080MS-0250NNCNN
	320	P1D-C080MS-0320NNCNN
<b>100</b> Conn. G1/2	25	P1D-C100MS-0025NNCNN
	40	P1D-C100MS-0040NNCNN
	50	P1D-C100MS-0050NNCNN
	80	P1D-C100MS-0080NNCNN
	100	P1D-C100MS-0100NNCNN
	125	P1D-C100MS-0125NNCNN
	160	P1D-C100MS-0160NNCNN
	200	P1D-C100MS-0200NNCNN
	250	P1D-C100MS-0250NNCNN
	320	P1D-C100MS-0320NNCNN
<b>125</b> Conn. G1/2	25	P1D-C125MS-0025NNCNN
	40	P1D-C125MS-0040NNCNN
	50	P1D-C125MS-0050NNCNN
	80	P1D-C125MS-0080NNCNN
	100	P1D-C125MS-0100NNCNN
	125	P1D-C125MS-0125NNCNN
	160	P1D-C125MS-0160NNCNN
	200	P1D-C125MS-0200NNCNN
	250	P1D-C125MS-0250NNCNN
	320	P1D-C125MS-0320NNCNN
500	P1D-C125MS-0500NNCNN	

The cylinders are supplied complete with one stainless steel piston rod nut and 4 sealing plugs to be used in the unused end cover screws.



# P1D Series Pneumatic Cylinders

## P1D Clean

The order numbers on this page refer to P1D Clean with two built-in reed sensors, factory-fitted in the cylinder end positions, with cable exit at the front end cover. See the order code key to select other sensors and other location of the cable exit.



## P1D Clean with Reed sensors, 1 m cable with 8 mm connector

Double acting

Cyl. bore mm	Stroke mm	Order code
<b>32</b> Conn. G1/8	25	P1D-C032MS-0025NNMNN
	40	P1D-C032MS-0040NNMNN
	50	P1D-C032MS-0050NNMNN
	80	P1D-C032MS-0080NNMNN
	100	P1D-C032MS-0100NNMNN
	125	P1D-C032MS-0125NNMNN
	160	P1D-C032MS-0160NNMNN
	200	P1D-C032MS-0200NNMNN
	250	P1D-C032MS-0250NNMNN
	320	P1D-C032MS-0320NNMNN
<b>40</b> Conn. G1/4	25	P1D-C040MS-0025NNMNN
	40	P1D-C040MS-0040NNMNN
	50	P1D-C040MS-0050NNMNN
	80	P1D-C040MS-0080NNMNN
	100	P1D-C040MS-0100NNMNN
	125	P1D-C040MS-0125NNMNN
	160	P1D-C040MS-0160NNMNN
	200	P1D-C040MS-0200NNMNN
	250	P1D-C040MS-0250NNMNN
	320	P1D-C040MS-0320NNMNN
<b>50</b> Conn. G1/4	25	P1D-C050MS-0025NNMNN
	40	P1D-C050MS-0040NNMNN
	50	P1D-C050MS-0050NNMNN
	80	P1D-C050MS-0080NNMNN
	100	P1D-C050MS-0100NNMNN
	125	P1D-C050MS-0125NNMNN
	160	P1D-C050MS-0160NNMNN
	200	P1D-C050MS-0200NNMNN
	250	P1D-C050MS-0250NNMNN
	320	P1D-C050MS-0320NNMNN
<b>63</b> Conn. G3/8	25	P1D-C063MS-0025NNMNN
	40	P1D-C063MS-0040NNMNN
	50	P1D-C063MS-0050NNMNN
	80	P1D-C063MS-0080NNMNN
	100	P1D-C063MS-0100NNMNN
	125	P1D-C063MS-0125NNMNN
	160	P1D-C063MS-0160NNMNN
	200	P1D-C063MS-0200NNMNN
	250	P1D-C063MS-0250NNMNN
	320	P1D-C063MS-0320NNMNN

Cyl. bore mm	Stroke mm	Order code
<b>80</b> Conn. G3/8	25	P1D-S080MS-0025NNMNN
	40	P1D-C080MS-0040NNMNN
	50	P1D-C080MS-0050NNMNN
	80	P1D-C080MS-0080NNMNN
	100	P1D-C080MS-0100NNMNN
	125	P1D-C080MS-0125NNMNN
	160	P1D-C080MS-0160NNMNN
	200	P1D-C080MS-0200NNMNN
	250	P1D-C080MS-0250NNMNN
	320	P1D-C080MS-0320NNMNN
<b>100</b> Conn. G1/2	25	P1D-C100MS-0025NNMNN
	40	P1D-C100MS-0040NNMNN
	50	P1D-C100MS-0050NNMNN
	80	P1D-C100MS-0080NNMNN
	100	P1D-C100MS-0100NNMNN
	125	P1D-C100MS-0125NNMNN
	160	P1D-C100MS-0160NNMNN
	200	P1D-C100MS-0200NNMNN
	250	P1D-C100MS-0250NNMNN
	320	P1D-C100MS-0320NNMNN
<b>125</b> Conn. G1/2	25	P1D-C125MS-0025NNMNN
	40	P1D-C125MS-0040NNMNN
	50	P1D-C125MS-0050NNMNN
	80	P1D-C125MS-0080NNMNN
	100	P1D-C125MS-0100NNMNN
	125	P1D-C125MS-0125NNMNN
	160	P1D-C125MS-0160NNMNN
	200	P1D-C125MS-0200NNMNN
	250	P1D-C125MS-0250NNMNN
	320	P1D-C125MS-0320NNMNN

The cylinders are supplied complete with one stainless steel piston rod nut and 4 sealing plugs to be used in the unused end cover screws.

# P1D Series Pneumatic Cylinders

## P1D Clean without sensor function

The only exception from the 20-digit part number is one version of P1D Clean which has a 15-digit order number. This version is a permanently sealed P1D Clean with no facility for installing sensors. The exterior of this cylinder is characterised by not having the big transparent cover, it has instead two short covers with a transparent moulding between. The cylinder has a very clean design and is intended for applications where no sensors are used.

The P1D without the sensor function can of course be combined with other equipment and functions by using a 20-digit order number. But please note that the letter N must always be used in position 18.



1	2	3	4	5	6	7	8	9	10	11	12	13	14	15
P	1	D	-	C	0	4	0	M	S	-	0	2	5	0

Cylinder version	
S	Standard
<b>C</b>	<b>Clean</b>
F	Flexible Porting
T	Tie-Rod

**P1D Clean without sensor function is defined by the letter C in position 5 and the 15-digit order number**

### Double acting

Cyl. bore mm	Stroke mm	Order code
<b>32</b> Conn. G1/8	25	<b>P1D-C032MS-0025</b>
	40	<b>P1D-C032MS-0040</b>
	50	<b>P1D-C032MS-0050</b>
	80	<b>P1D-C032MS-0080</b>
	100	<b>P1D-C032MS-0100</b>
	125	<b>P1D-C032MS-0125</b>
	160	<b>P1D-C032MS-0160</b>
	200	<b>P1D-C032MS-0200</b>
	250	<b>P1D-C032MS-0250</b>
	320	<b>P1D-C032MS-0320</b>
400	<b>P1D-C032MS-0400</b>	
500	<b>P1D-C032MS-0500</b>	
<b>40</b> Conn. G1/4	25	<b>P1D-C040MS-0025</b>
	40	<b>P1D-C040MS-0040</b>
	50	<b>P1D-C040MS-0050</b>
	80	<b>P1D-C040MS-0080</b>
	100	<b>P1D-C040MS-0100</b>
	125	<b>P1D-C040MS-0125</b>
	160	<b>P1D-C040MS-0160</b>
	200	<b>P1D-C040MS-0200</b>
	250	<b>P1D-C040MS-0250</b>
	320	<b>P1D-C040MS-0320</b>
400	<b>P1D-C040MS-0400</b>	
500	<b>P1D-C040MS-0500</b>	
<b>50</b> Conn. G1/4	25	<b>P1D-C050MS-0025</b>
	40	<b>P1D-C050MS-0040</b>
	50	<b>P1D-C050MS-0050</b>
	80	<b>P1D-C050MS-0080</b>
	100	<b>P1D-C050MS-0100</b>
	125	<b>P1D-C050MS-0125</b>
	160	<b>P1D-C050MS-0160</b>
	200	<b>P1D-C050MS-0200</b>
	250	<b>P1D-C050MS-0250</b>
	320	<b>P1D-C050MS-0320</b>
400	<b>P1D-C050MS-0400</b>	
500	<b>P1D-C050MS-0500</b>	

Cyl. bore mm	Stroke mm	Order code
<b>63</b> Conn. G3/8	25	<b>P1D-C063MS-0025</b>
	40	<b>P1D-C063MS-0040</b>
	50	<b>P1D-C063MS-0050</b>
	80	<b>P1D-C063MS-0080</b>
	100	<b>P1D-C063MS-0100</b>
	125	<b>P1D-C063MS-0125</b>
	160	<b>P1D-C063MS-0160</b>
	200	<b>P1D-C063MS-0200</b>
	250	<b>P1D-C063MS-0250</b>
	320	<b>P1D-C063MS-0320</b>
400	<b>P1D-C063MS-0400</b>	
500	<b>P1D-C063MS-0500</b>	
<b>80</b> Conn. G3/8	25	<b>P1D-C080MS-0025</b>
	40	<b>P1D-C080MS-0040</b>
	50	<b>P1D-C080MS-0050</b>
	80	<b>P1D-C080MS-0080</b>
	100	<b>P1D-C080MS-0100</b>
	125	<b>P1D-C080MS-0125</b>
	160	<b>P1D-C080MS-0160</b>
	200	<b>P1D-C080MS-0200</b>
	250	<b>P1D-C080MS-0250</b>
	320	<b>P1D-C080MS-0320</b>
400	<b>P1D-C080MS-0400</b>	
500	<b>P1D-C080MS-0500</b>	
<b>100</b> Conn. G1/2	25	<b>P1D-C100MS-0025</b>
	40	<b>P1D-C100MS-0040</b>
	50	<b>P1D-C100MS-0050</b>
	80	<b>P1D-C100MS-0080</b>
	100	<b>P1D-C100MS-0100</b>
	125	<b>P1D-C100MS-0125</b>
	160	<b>P1D-C100MS-0160</b>
	200	<b>P1D-C100MS-0200</b>
	250	<b>P1D-C100MS-0250</b>
	320	<b>P1D-C100MS-0320</b>
400	<b>P1D-C100MS-0400</b>	
500	<b>P1D-C100MS-0500</b>	

Cyl. bore mm	Stroke mm	Order code
<b>125</b> Conn. G1/2	25	<b>P1D-C125MS-0025</b>
	40	<b>P1D-C125MS-0040</b>
	50	<b>P1D-C125MS-0050</b>
	80	<b>P1D-C125MS-0080</b>
	100	<b>P1D-C125MS-0100</b>
	125	<b>P1D-C125MS-0125</b>
	160	<b>P1D-C125MS-0160</b>
	200	<b>P1D-C125MS-0200</b>
	250	<b>P1D-C125MS-0250</b>
	320	<b>P1D-C125MS-0320</b>
400	<b>P1D-C125MS-0400</b>	
500	<b>P1D-C125MS-0500</b>	

The cylinders are supplied complete with one stainless steel piston rod nut and 4 sealing plugs to be used in the unused end cover screws.

# P1D Series Pneumatic Cylinders

## P1D Flexible Porting

The P1D Flexible Porting with both cylinder ports in one end cover has a 20-digit part number. Position 11 is used to select the position of the cylinder ports (all cylinders with one connection in each end cover have a dash in this position). Please note that cylinder bores 32-63 mm only have the push-in fitting design and 80-125 mm is only available with threaded connections. Position 20 is used to specify the type of push-in fittings (low elbow or straight fitting) and tube dimension (4 or 6 mm

for Ø32 and 40, and 8 or 10 mm for Ø50 and 63). For cylinder bores Ø32-63 mm, the fittings are made of plastics material for Flexible Porting cylinders (nickel plated brass on all other P1D cylinders). These four smallest bores can not be equipped with speed controls. For cylinder bores Ø80-125 mm, position 20 is used to select the speed controls, fittings (Prestolok, nickel plated brass) or none (code N).

1	2	3	4	5	6	7	8	9	10	11	12	13	14	15	16	17	18	19	20
<b>P</b>	<b>1</b>	<b>D</b>	-	<b>F</b>	<b>0</b>	<b>6</b>	<b>3</b>	<b>M</b>	<b>S</b>	<b>B</b>	<b>0</b>	<b>3</b>	<b>2</b>	<b>0</b>	<b>N</b>	<b>N</b>	<b>N</b>	<b>N</b>	<b>0</b>

Cylinder version	
<b>S</b>	Standard
<b>C</b>	Clean
<b>F</b>	Flexible Porting
<b>T</b>	Tie-Rod

Cylinder ports				
	Front & rear	Both front	Both rear	
-	<b>H</b> <sup>3)</sup>	<b>J</b> <sup>3)</sup>		G threads, BSPP (Ø80-125 mm)
-	<b>B</b> <sup>4)</sup>	<b>C</b> <sup>4)</sup>		Push-in , metric (Ø32-63 mm)

Speed controls or fittings for tube dimension	
<b>Speed controls</b> <sup>17)</sup> <b>Series PTF4PB</b> <sup>16)</sup>	
<b>X</b>	in both ends for tube 4 mm
<b>Y</b>	in both ends for tube 6 mm
<b>Z</b>	in both ends for tube 8 mm
<b>P</b>	in both ends for tube 10 mm
<b>R</b>	in both ends for tube 12 mm
<b>Push-in fitting, elbow type for:</b>	
<b>4</b>	Tube dimension 4 mm
<b>6</b>	Tube dimension 6 mm
<b>8</b>	Tube dimension 8 mm
<b>0</b>	Tube dimension 10 mm
<b>2</b>	Tube dimension 12 mm
<b>Push-in fitting, straight type for:</b>	
<b>1</b>	Tube dimension 4 mm
<b>3</b>	Tube dimension 6 mm
<b>5</b>	Tube dimension 8 mm
<b>7</b>	Tube dimension 10 mm
<b>9</b>	Tube dimension 12 mm
<b>N</b>	None

3) Only for P1D-F bore 80-125 mm. Select optional fittings in position 20.

4) Only for P1D-F bore 32-63 mm. Select fittings in position 20.

16) P1D Clean cylinders have factory installed nickel plated versions of the PTF series.

17) Not available for P1D Flexible Porting bore 32-63 mm.

Available fittings and speed controls for P1D Flexible Porting			
Cyl. bore	Speed controls for tube	Elbow fitting for tube	Straight fitting for tube
<b>32, 40</b>	not available	4, 6	4, 6
<b>50, 63</b>	not available	8, 10	8, 10
<b>80</b>	8, 10, 12	8, 10, 12	8, 10, 12
<b>100, 125</b>	12	12	10, 12

### Examples of P1D Flexible Porting

P1D-F050MSB0160SMKN8 Flexible Porting cylinder with two plug-in low elbow fittings for 8 mm tube, placed at front end cover, zinc plated steel swivel rod eye, combination clevis bracket GA and swivel eye bracket installed on rear end cover, two factory-fitted reed sensors with 3 m cable.

P1D-F080MSH0500BFCN Flexible Porting cylinder with two threaded connections in front end cover, zinc plated steel clevis, foot brackets, two factory-fitted electronic sensors, PNP type, with 8 mm connector (0.3 m cable), sealing plugs installed in unused end cover screws.

P1D-F032MSB0250NNNN6 Flexible Porting cylinder with two push-in elbow fittings for 6 mm tube, placed at front end cover.

P1D-F063MSC0400NNNN7 Flexible Porting cylinder with two straight push-in fittings for 10 mm tube, placed at rear end cover (only possible to choose 8 or 10 mm for cylinder bore 50 and 63 mm).

P1D-F125MSJ0600NNNNN Flexible Porting cylinder with two threaded connections in rear end cover.

# P1D Series Pneumatic Cylinders

## P1D Flexible Porting

The order codes on this page refer to P1D Flexible Porting with both cylinder ports in the front end cover and with factory-fitted push-in elbow fittings. For Ø32-63 mm, the fittings are made of plastic, whereas Ø80-125 mm can be ordered with threaded ports only or with push-in Prestolok nickel plated brass fittings. See the order key to select fittings.



## P1D Flexible Porting

Double acting

Cyl. bore mm	Stroke mm	Order code
<b>32</b> Push-in elbow 6 mm	25	P1D-F032MSB0025NNNN6
	40	P1D-F032MSB0040NNNN6
	50	P1D-F032MSB0050NNNN6
	80	P1D-F032MSB0080NNNN6
	100	P1D-F032MSB0100NNNN6
	125	P1D-F032MSB0125NNNN6
	160	P1D-F032MSB0160NNNN6
	200	P1D-F032MSB0200NNNN6
	250	P1D-F032MSB0250NNNN6
	320	P1D-F032MSB0320NNNN6
	400	P1D-F032MSB0400NNNN6
500	P1D-F032MSB0500NNNN6	
<b>40</b> Push-in elbow 6 mm	25	P1D-F040MSB0025NNNN6
	40	P1D-F040MSB0040NNNN6
	50	P1D-F040MSB0050NNNN6
	80	P1D-F040MSB0080NNNN6
	100	P1D-F040MSB0100NNNN6
	125	P1D-F040MSB0125NNNN6
	160	P1D-F040MSB0160NNNN6
	200	P1D-F040MSB0200NNNN6
	250	P1D-F040MSB0250NNNN6
	320	P1D-F040MSB0320NNNN6
	400	P1D-F040MSB0400NNNN6
500	P1D-F040MSB0500NNNN6	
<b>50</b> Push-in elbow 10 mm	25	P1D-F050MSB0025NNNN0
	40	P1D-F050MSB0040NNNN0
	50	P1D-F050MSB0050NNNN0
	80	P1D-F050MSB0080NNNN0
	100	P1D-F050MSB0100NNNN0
	125	P1D-F050MSB0125NNNN0
	160	P1D-F050MSB0160NNNN0
	200	P1D-F050MSB0200NNNN0
	250	P1D-F050MSB0250NNNN0
	320	P1D-F050MSB0320NNNN0
	400	P1D-F050MSB0400NNNN0
500	P1D-F050MSB0500NNNN0	
<b>63</b> Push-in elbow 10 mm	25	P1D-F063MSB0025NNNN0
	40	P1D-F063MSB0040NNNN0
	50	P1D-F063MSB0050NNNN0
	80	P1D-F063MSB0080NNNN0
	100	P1D-F063MSB0100NNNN0
	125	P1D-F063MSB0125NNNN0
	160	P1D-F063MSB0160NNNN0
	200	P1D-F063MSB0200NNNN0
	250	P1D-F063MSB0250NNNN0
	320	P1D-F063MSB0320NNNN0
	400	P1D-F063MSB0400NNNN0
500	P1D-F063MSB0500NNNN0	

## P1D Flexible Porting

Double acting

Cyl. bore mm	Stroke mm	Order code
<b>80</b> Push-in elbow 10 mm	25	P1D-S080MSH0025NNNN0
	40	P1D-F080MSH0040NNNN0
	50	P1D-F080MSH0050NNNN0
	80	P1D-F080MSH0080NNNN0
	100	P1D-F080MSH0100NNNN0
	125	P1D-F080MSH0125NNNN0
	160	P1D-F080MSH0160NNNN0
	200	P1D-F080MSH0200NNNN0
	250	P1D-F080MSH0250NNNN0
	320	P1D-F080MSH0320NNNN0
	400	P1D-F080MSH0400NNNN0
500	P1D-F080MSH0500NNNN0	
<b>100</b> Push-in elbow 12 mm	25	P1D-F100MSH0025NNNN2
	40	P1D-F100MSH0040NNNN2
	50	P1D-F100MSH0050NNNN2
	80	P1D-F100MSH0080NNNN2
	100	P1D-F100MSH0100NNNN2
	125	P1D-F100MSH0125NNNN2
	160	P1D-F100MSH0160NNNN2
	200	P1D-F100MSH0200NNNN2
	250	P1D-F100MSH0250NNNN2
	320	P1D-F100MSH0320NNNN2
	400	P1D-F100MSH0400NNNN2
500	P1D-F100MSH0500NNNN2	
<b>125</b> Push-in elbow 12 mm	25	P1D-F125MSH0025NNNN2
	40	P1D-F125MSH0040NNNN2
	50	P1D-F125MSH0050NNNN2
	80	P1D-F125MSH0080NNNN2
	100	P1D-F125MSH0100NNNN2
	125	P1D-F125MSH0125NNNN2
	160	P1D-F125MSH0160NNNN2
	200	P1D-F125MSH0200NNNN2
	250	P1D-F125MSH0250NNNN2
	320	P1D-F125MSH0320NNNN2
	400	P1D-F125MSH0400NNNN2
500	P1D-F125MSH0500NNNN2	

The cylinders are supplied complete with one zinc plated steel piston rod nut.

**Combine P1D Clean and P1D Flexible Porting**

All Clean cylinders can be combined with the connections in the front or rear end cover in accordance with the Flexible Porting design. Specify cylinder version C in position 5, position of connection ports in position 11 (codes H, J, B or C), choice of built-in sensors in position 18 and type of fitting and

tube dimension in position 20. Naturally, the cylinder can be equipped with piston rod fittings and cylinder mountings in positions 16 and 17 if required. As with all clean cylinders a set of 4 sealing plugs is enclosed for installation in unused end cover screws.

1	2	3	4	5	6	7	8	9	10	11	12	13	14	15	16	17	18	19	20
<b>P</b>	<b>1</b>	<b>D</b>	-	<b>C</b>	<b>0</b>	<b>5</b>	<b>0</b>	<b>M</b>	<b>S</b>	<b>B</b>	<b>0</b>	<b>3</b>	<b>2</b>	<b>0</b>	<b>N</b>	<b>N</b>	<b>C</b>	<b>N</b>	<b>8</b>

Cylinder version	
<b>S</b>	Standard
<b>C</b>	Clean <sup>2)</sup>
<b>F</b>	Flexible Porting
<b>T</b>	Tie-Rod

Cylinder ports		
Front & rear	Both front	Both rear
<b>Port location</b>		
-	<b>H</b> <sup>3)</sup>	<b>J</b> <sup>3)</sup>
G threads, BSPP (Ø80-125 mm)		
-	<b>B</b> <sup>4)</sup>	<b>C</b> <sup>4)</sup>
Push-in , metric (Ø32-63 mm)		

Factory-fitted sensors			
Front end or left <sup>11)</sup>	Rear end or right <sup>11)</sup>	Front and rear end	<b>Cable exit</b>
<b>F</b>	<b>R</b>	-	2 sensors 24 VDC PNP, 3 m cable
<b>G</b>	<b>H</b>	-	2 sensors 24 VDC PNP, 10 m cable
<b>C</b>	<b>S</b>	-	2 sensors 24 VDC PNP, 8 mm connector, 1 m cable <sup>21)</sup>
<b>K</b>	<b>L</b>	-	2 sensors Reed type, 3 m cable
<b>T</b>	<b>V</b>	-	2 sensors Reed type, 10 m cable
<b>M</b>	<b>Q</b>	-	2 sensors Reed type, 8 mm connector, 1 m cable <sup>21)</sup>
-	-	<b>3</b>	3 sensors 24 VDC PNP, 8 mm connector, 1 m cable <sup>21)</sup>
-	-	<b>Z</b>	3 sensors Reed type, 8 mm connector, 1 m cable <sup>21)</sup>
-	-	<b>4</b>	4 sensors 24 VDC PNP, 8 mm connector, 1 m cable <sup>21)</sup>
-	-	<b>W</b>	4 sensors Reed type, 8 mm connector, 1 m cable <sup>21)</sup>
<b>6</b> <sup>12)</sup>	<b>7</b> <sup>13)</sup>	<b>8</b> <sup>14)</sup>	No factory-fitted sensors P1D Clean
<b>N</b>			No sensors P1D (excl. P1D Clean)

Speed controls or fittings for tube dimension	
<b>Speed controls</b> <sup>17)</sup> Series PTF 4/8PB <sup>16)</sup>	
<b>X</b>	in both ends for tube 4 mm <sup>15)</sup>
<b>Y</b>	in both ends for tube 6 mm <sup>15)</sup>
<b>Z</b>	in both ends for tube 8 mm <sup>15)</sup>
<b>P</b>	in both ends for tube 10 mm <sup>15)</sup>
<b>R</b>	in both ends for tube 12 mm <sup>15)</sup>
<b>Push-in fitting, elbow type for:</b>	
<b>4</b>	Tube dimension 4 mm <sup>15)</sup>
<b>6</b>	Tube dimension 6 mm <sup>15)</sup>
<b>8</b>	Tube dimension 8 mm <sup>15)</sup>
<b>0</b>	Tube dimension 10 mm <sup>15)</sup>
<b>2</b>	Tube dimension 12 mm <sup>15)</sup>
<b>Push-in fitting, straight type for:</b>	
<b>1</b>	Tube dimension 4 mm <sup>15)</sup>
<b>3</b>	Tube dimension 6 mm <sup>15)</sup>
<b>5</b>	Tube dimension 8 mm <sup>15)</sup>
<b>7</b>	Tube dimension 10 mm <sup>15)</sup>
<b>9</b>	Tube dimension 12 mm <sup>15)</sup>
<b>N</b>	None

- 2) P1D Clean without sensor function, see page 41.
- 3) Only for P1D-F bore 80-125 mm. Select optional fittings in position 20.
- 4) Only for P1D-F bore 32-63 mm. Select fittings in position 20.
- 11) Left and right valid for P1D Standard and P1D Tie-Rod seen from behind with the ports on top. The sensors can only be mounted on the left for P1D Flexible Porting.
- 12) No factory-fitted sensors, but prepared for cable exit in the front end (max. 2 sensors).
- 13) No factory-fitted sensors, but prepared for cable exit in the rear end (max. 2 sensors).
- 14) No factory-fitted sensors, but prepared for cable exit in both ends (max. 4 sensors).
- 15) To choose speed control and couplings, please refer to page 42.
- 16) P1D Clean cylinders have factory fitted nickel plated versions of the PTF series.
- 17) Not available with P1D Flexible Porting bore 32-63 mm.
- 21) Due to the sensor positions, the cable length (1 m) could limit the stroke of the P1D Clean cylinders.

**Examples of P1D Clean in combination with Flexible Porting**

P1D-C032MSC0200NNSN6 P1D Clean cylinder with two push-in elbow fittings for 6 mm tube, placed at front end cover, two factory-fitted electronic sensors, PNP type, with 8 mm connector, cable exit at rear end cover, 4 sealing plugs for end cover screws are enclosed.

P1D-C080MSJ0500AN3N0 P1D Clean cylinder with two threaded connections in rear end cover, factory-fitted push-in elbow fittings (Prestolok, nickel plated brass) for 10 mm tube in both connections, three factory-fitted electronic sensors, PNP type, with 8 mm connector, cable exit in both front and rear end covers, zinc plated steel swivel rod eye, 4 sealing plugs are installed in unused end cover screws.





**VIKING** ~~X~~ **TREME**



### P1D complete working unit

P1D Standard can be ordered with a factory-fitted valve and tubing. The valve series is the robust and compact Viking Xtreme series, with product code P2LAX (for cylinder bores 32-63), P2LBX (for cylinder bores 80-100) and P2LDX (for cylinder bore 125). This valve series was specially designed for harsh environments and a long service life. The valve is securely fitted to a fixing plate bolted onto the cylinder barrel. The unit is delivered complete with valve, Prestolok push-in connection in nickel plated brass, and hosing. The valve has built-in silencers (Siflow for speed regulation), and electrically-operated versions have solenoid valves (P2E with spring-loaded manual override) and a cable head with LED and spark dispersion. The supply voltage is 24V for AC as well as DC versions. This UC (Universal Current) is possible because of a built-in rectifier in the cable head, allowing the use of direct current and alternating current for actuation. Of course, the entire range of P1D accessories can also be used for the P1D with built-in valve, and cylinders can be ordered with factory-fitted accessories and sensors.

### Fast response

The large flow capacity of the valve and the short distance between the valve and the cylinder ports mean that the working unit operates quickly (short actuation time and with minimal flow restriction).

### No maintenance and easy to service

The working unit is built from standard components. The cylinders and the valves are designed to be used without supplementary lubrication.

### Wide range of applications

The complete working unit can be used in silo applications, for operating flaps and valves, in sawmills and in many similar installations in which the cylinders are scattered or the fast actuation is important. The unit with the valve installed is compact, so it can also be used in small spaces.

### Range of solenoid valve voltages

The solenoid valves are available in the standard voltages, for example;

24 V UC (24 V AC/DC, Universal Current)  
115 V/50 Hz, 120 V/60 Hz  
230 V/50 Hz, 240 V/60 Hz

**Technical data**

Working pressure	max 10 bar	
Working media	dry filtered compressed air. Please refer to page 18.	
Working temperature:	-40 °C to +70 °C (-15 °C to +60 °C with solenoid valve)	
Flow, P2LAX, acc. to ISO 6358	Qn = 720 NI/min	
Flow, P2LBX, acc. to ISO 6358	Qn = 1290 NI/min	
Flow, P2LDX, acc. to ISO 6358	Qn = 2650 NI/min	
Solenoid power consumption	Pull	Hold
P2E-KV32C1, 24 V DC	1,2 W	1,2 W
P2E-KV31C1, 24 VAC	3,5 VA	1,6 VA

**Material specification**

P1D cylinders	please refer to page 19.
Valves <sup>1)</sup>	
Housing and ends	Anodised aluminium
Solenoid valves	
Housing	Polyamide
Magnet coil	Epoxy coated
Fixing plate	Anodised aluminium
Fixing screws for plate	Stainless steel
Fixing screws for valve	Zinc-coated steel
Angle connections	Nickel-coated brass
Plastic tubes	PUR

1) see also catalogue for P2L series Viking Xtreme valves

**Accessories**

Name	Order code
Siflow silencer for P2LAX valve, G1/8	<b>9301050901</b>
Sintered plastic silencer for P2LAX valve, G1/8	<b>P6M-PAB1</b>
Siflow silencer for P2LBX valve, G1/4	<b>9301050902</b>
Sintered plastic silencer for P2LBX valve, G1/4	<b>P6M-PAB2</b>
Siflow silencer for P2LDX valve, G1/2	<b>9301050904</b>
Sintered plastic silencer for P2LDX valve, G1/2	<b>P6M-PAB4</b>
Fixing plate for Ø32 - Ø63, valve P2LAX, -BX	<b>9121742111</b>
Fixing plate for Ø80, Ø100, valve P2LAX, -BX, -DX	<b>9121742112</b>
Fixing plate for Ø125, valve P2LAX, -BX, -DX	<b>9121742113</b>

**Cable plugs DIN 43650, form C**

Name	Order code
12-24 VAC/DC, VDR + LED + REC IP65	<b>P8C-H36C</b>
110-120 VAC/DC, VDR + LED IP65	<b>P8C-H21E</b>
220-240 VAC/DC, VDR + LED IP65	<b>P8C-H21G</b>

**Factory Fitted Valve**

A 20-character order number is used to order the P1D Standard with factory fitted valve. Position 5 indicates the cylinder version, with the actuation type in position 11 and the valve type in position 20. Note that cylinder diameters 32-63 use valve P2LAX (1/8"), diameters 80-100 use P2LBX (1/4"),

and diameter 125 uses P2LDX (1/2"). This version of the cylinder can of course be combined with factory-fitted cylinder accessories, piston rod accessories and sensors. Fixing plates for different valve sizes may be ordered separately.

1	2	3	4	5	6	7	8	9	10	11	12	13	14	15	16	17	18	19	20
<b>P</b>	<b>1</b>	<b>D</b>	<b>-</b>	<b>V</b>	<b>0</b>	<b>5</b>	<b>0</b>	<b>M</b>	<b>S</b>	<b>1</b>	<b>0</b>	<b>3</b>	<b>2</b>	<b>0</b>	<b>N</b>	<b>N</b>	<b>N</b>	<b>N</b>	<b>H</b>

**Cylinder version**

<b>V</b>	Standard with factory fitted valve
<b>4</b>	Standard with lock unit and factory fitted valve

**Factory fitted valve type**

<b>0</b>	Air actuated
<b>1</b>	Electrically actuated 24 V UC, LED+VDR (AC/DC Universal Current) Complete with rectifier
<b>4</b>	Electrically actuated 24 V UC, LED+VDR with 5 m integral cable (AC/DC Universal Current) Complete with rectifier
<b>7</b>	Electrically actuated 24 V UC, LED+VDR with 10 m integral cable (AC/DC Universal Current) Complete with rectifier
<b>2</b>	Electrically actuated 115 V/50 Hz, 120 V/60 Hz, LED+VDR
<b>3</b>	Electrically actuated 230 V/50 Hz, 240 V/60 Hz, LED+VDR

**Valve function**

<b>Air actuated</b>	
<b>A</b>	Air-Air, 5/2
<b>B</b>	Air-Spring, 5/2
<b>C</b>	Air-Air, 5/3, closed centre position
<b>D</b>	Air-Air, 5/3, vented centre
<b>E</b>	Air-Air, 5/3, pressurised centre
<b>Electrically actuated internal supply</b>	
<b>F</b>	Elec-Elec, 5/2
<b>H</b>	Elec-Spring, 5/2
<b>K</b>	Spring-Elec*, 5/2
<b>M</b>	Elec-Elec, 5/3, closed centre position
<b>Q</b>	Elec-Elec, 5/3, vented centre
<b>S</b>	Elec-Elec, 5/3, pressurised centre
<b>Electrically actuated external supply</b>	
<b>G</b>	Elec-Elec, 5/2
<b>J</b>	Elec-Spring, 5/2
<b>L</b>	Spring-Elec*, 5/2

\* Piston rod in extended position with unactuated valve



CAD drawings on the Internet

Our home page [www.parker.com/euro\\_pneumatic](http://www.parker.com/euro_pneumatic) includes the AirCad Drawing Library with 2D and 3D drawings for the main versions.

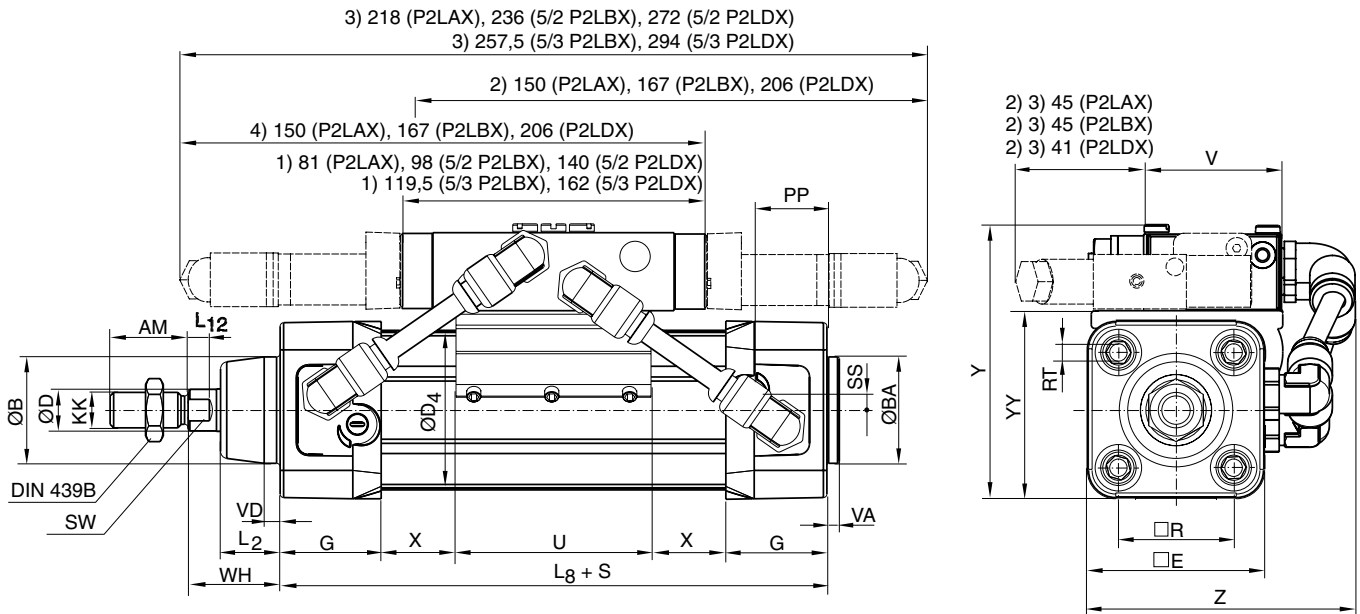

Dimensions

Cylinder bore mm	AM mm	B mm	BA mm	BG mm	D mm	D4 mm	E mm	G mm	KK	L2 mm	L8 mm	L12 mm
32	22	30	30	16	12	45,0	50,0	28,5	M10x1,25	16,0	94	6,0
40	24	35	35	16	16	52,0	57,4	33,0	M12x1,25	19,0	105	6,5
50	32	40	40	16	20	60,7	69,4	33,5	M16x1,5	24,0	106	8,0
63	32	45	45	16	20	71,5	82,4	39,5	M16x1,5	24,0	121	8,0
80	40	45	45	17	25	86,7	99,4	39,5	M20x1,5	30,0	128	10,0
100	40	55	55	17	25	106,7	116,0	44,5	M20x1,5	32,4	138	14,0
125	54	60	60	20	32	134,0	139,0	51,0	M27x2	45,0	160	18,0

Cylinder bore mm	PP mm	R mm	RT	SS mm	SW mm	VA mm	VD mm	WH mm	U mm	V mm	X mm
32	21,8	32,5	M6	4,0	10	3,5	4,5	26	55	40	-9+S/2
40	21,9	38,0	M6	8,0	13	3,5	4,5	30	55	40	-8+S/2
50	23,0	46,5	M8	4,0	17	3,5	5,0	37	55	40	-8+S/2
63	27,4	56,5	M8	6,5	17	3,5	5,0	37	55	40	-6,5+S/2
80	30,5	72,0	M10	0	22	3,5	4,0	46	55	40	-2,5+S/2
100	35,8	89,0	M10	0	22	3,5	4,0	51	55	40	-2,5+S/2
125	40,5	110,0	M12	0	27	5,5	6,0	65	55	48	2+S/2

Cylinder bore mm	Y mm	YY mm	Z mm	ZZ mm
32	80	56	80	90
40	88	64	87	96
50	102	78	96	105
63	109	85	107	116
80	127	102	132	125
100	142	117	148	140
125	180	146	183	159

S=Stroke

- 1) Air actuated 5/2 and 5/3
- 2) Electrically actuated 5/2 with spring return
- 3) Electrically actuated 5/2 and 5/3 (2 solenoid valves)
- 4) Electrically actuated 5/2 with spring return(reverse function)

- P2LAX Ø32 - Ø63 mm
- P2LBX Ø80 - Ø100 mm
- P2LDX Ø125 mm



**P1D-L****P1D-D****P1D cylinder with piston rod locking**

The P1D cylinder is available in a version with piston rod locking, allowing the piston rod to be locked in any position. The lock unit, of the air/spring actuated type, is integrated in the front end piece of the cylinder. With no signal pressure, the full force of the lock is applied to the piston rod, and the lock is released at 4 bar signal pressure. Lock units are available for P1D Standard (P1D-L) and P1D Clean (P1D-D) in bores 32-125 mm. P1D Standard can be ordered with a lock unit and a built-in valve (P1D-4). Of course, the entire range of P1D accessories can also be used for the locking cylinder, which can be ordered with factory fitted accessories, sensors and valves. However, the lock unit increases the overall length of the cylinder. Compare the dimensional diagrams on pages 26 and 50. The overall dimensions specified in the catalogue for built-in cylinder fittings, pages 55 - 63, are only correct for P1D standard versions without lock unit.

**Clean and compact design**

The front end piece and lock unit form an integrated block, keeping the length of the structure short. The design is easy to clean, sealed and waterproof. The exhaust air from the

lock unit can be removed by replacing the filter unit with a connector and hose. This is an advantage in terms of cleaning or when environmental factors are important.

**Locking and braking.**

The static locking force corresponds to 7 bar pressure. Under certain circumstances, the lock can also be used as a brake for positioning or similar applications. The maximum values set out in the graph on page 48 must not be exceeded.

**Function on pressure loss**

The piston rod lock can be used in all material handling systems where controlled fastening or positioning is required. The piston rod lock is also suitable for use as a pressure-loss brake for cylinders with suspended loads, for example. See lock forces.

The signal air to the lock unit can be connected directly to the air system or to the supply air for the valve controlling the cylinder in question. For controlled on/off operation of the lock unit, a separate valve, with large exhaust flow capacity, is used.

**Technical data**

Working pressure	max 10 bar
Working media	dry filtered compressed air
Working temperature	-20 °C to +80 °C
Release pressure <sup>1)</sup>	min 4 bar

1) Signal pressure to inlet port of lock unit.

**Static lock forces**

Lock forces at 0 bar signal pressure to lock unit

Cylinder dia. mm	Lock force N
32	550
40	860
50	1345
63	2140
80	3450
100	5390
125	8425

**Material specification, piston rod locking**

Housing/end piece	Black anodised aluminium
Lock collar/piston	Hardened steel
Springs	Stainless steel
Piston rod seal Dim 32-40	UHMWPE plastic
Piston rod seal Dim 50-125	Polyurethane
O-rings	Nitrile rubber, NBR
Scraper ring	Polyurethane
Air filter	Brass/sintered bronze

Other data as for relevant base cylinder.

The cylinders are supplied with a hard chrome plated piston rod.

**NOTE!**  
If rod guidance module is to be fitted, the piston rod must be extended to provide the same WH dimensions as for the P1D base cylinder. Please refer to page 51.

**Speed [m/s]**

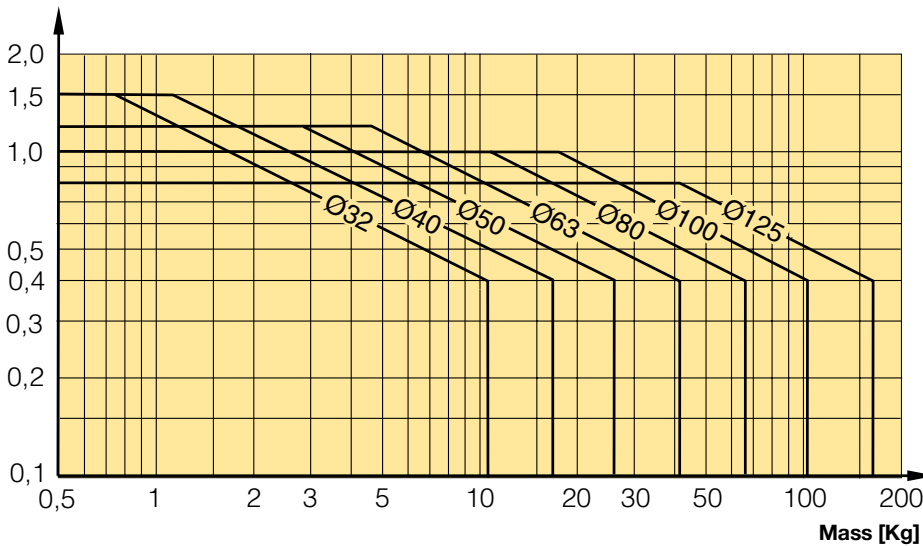

**Use as a brake**

The table shows the maximum values for speed and braking mass if the cylinder is used as a brake. The cylinder should not be exposed to additional compressive forces as this significantly reduces the external mass that can be braked. We recommend system solutions as shown at the top of page 45 (Fastening in position) or similar, in which the cylinder does not act as a motor during braking. Heat is generated if the brake is used frequently, and this must be taken into account to ensure that the maximum temperature is not exceeded.

**Piston rod locking**

To order a cylinder with piston rod locking, position 5 should contain L (P1D Standard with lock unit), D (P1D Clean cylinder with lock unit) or 4 (P1D with factory fitted valve and lock unit). Note that the P1D with piston rod locking requires a

chrome plated piston rod or chrome plated stainless steel piston rod because of the high surface pressure. For factory-fitted cylinder accessories, sensors, etc. please refer to the complete order code key on pages 78-79.

1	2	3	4	5	6	7	8	9	10	11	12	13	14	15
P	1	D	-	L	0	8	0	M	C	-	0	2	0	0

Cylinder version	
<b>L</b>	Standard with lock unit
<b>D</b>	Clean with lock unit
<b>4</b>	Standard with lock unit and factory fitted valve

Material		Seals
Piston rod		
Hard chrome plated steel	Hard chr. pl. stainless steel	
<b>C</b>	<b>R</b>	Standard -20 °C to +80 °C.

**Fastening in position**

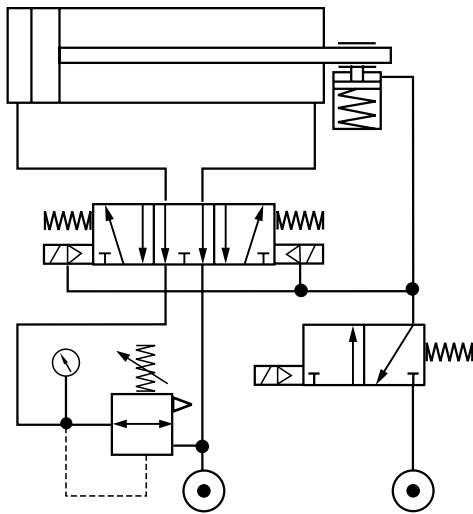

This is the optimum solution for straightforward fastening in any position, while preserving the maximum expected service life of the lock. The cylinder is supplied with compressed air via a 5/3 valve with vented centre. The valve is supplied with full pressure in port 3, port 2 is connected to the minus port on the cylinder, port 5 is supplied with a reduced pressure and port 4 is connected to the plus port on the cylinder. The reduced pressure to the cylinder plus port is to equalise the force, so that no forces can act on the lock when it is in the locked position. The solenoid valves of the 5/3 valve are supplied with compressed air from a 3/2 valve, which also supplies compressed air to release the lock. To cause the cylinder to move in either direction, the 3/2 must be actuated in order to release the lock and supply the solenoid valves with signal air, after which they can be actuated. This means that as soon as the 3/2 valve is deactuated, the lock is applied and no signal air is supplied to the solenoid valves, causing the 5/3 valve to switch to the centre position. The cylinder is now supplied by the two different pressure sources, is fully vented and no force is applied to the lock.

**Function on hose rupture**

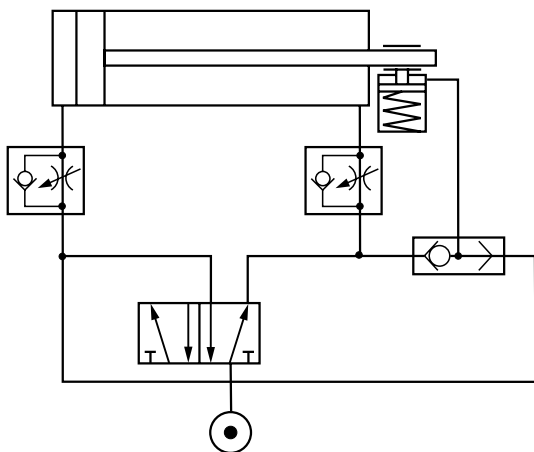

This arrangement helps to secure the piston rod if there is a pressure loss due to hose rupture. The cylinder is supplied by a 5/2 valve and the cylinder speed is controlled using flow control valves with by-pass fitted near the cylinder. A TEE piece is fitted in the pipe between the working valve and the cylinder, going to a changeover valve with air passing to the lock. In the event of a pressure loss, the pressure to the 5/2 valve ceases, as does the pressure via the changeover valve to the lock. The lock is then applied.

**Function on pressure loss**

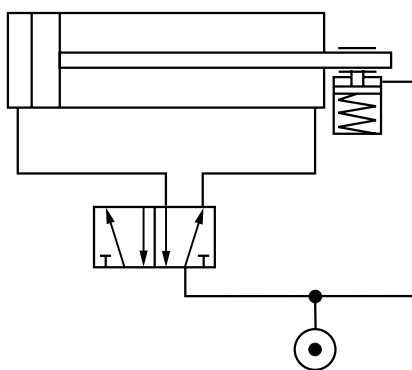

This solution is used to lock the cylinder in the event of a pressure loss in the system. A TEE piece is fitted in the pipe feeding the working valve for the cylinder. The lock on the cylinder is supplied from this TEE piece. In the event of a pressure loss, the lock is vented immediately and is applied.



CAD drawings on the Internet

Our home page [www.parker.com/euro\\_pneumatic](http://www.parker.com/euro_pneumatic) includes the AirCad Drawing Library with 2D and 3D drawings for the main versions.

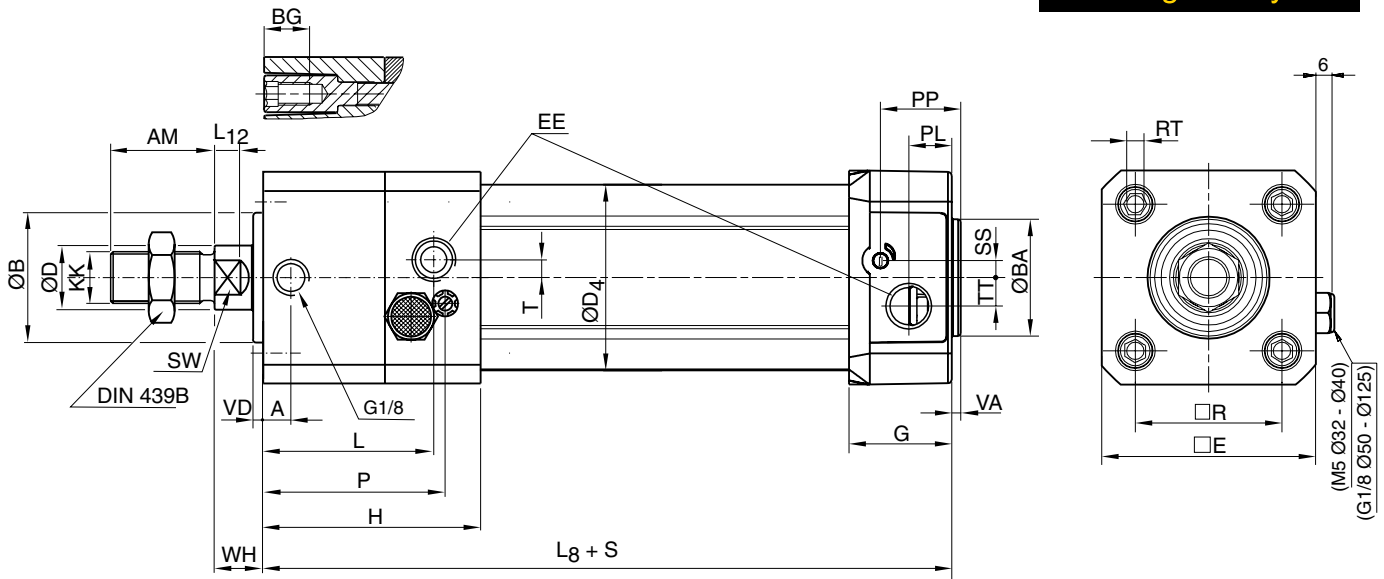

Dimensions

Cylinder bore mm	A	AM	B	BA	BG	D	D4	E	EE	G	H	KK	L
mm	mm	mm	mm	mm	mm	mm	mm	mm	mm	mm	mm	mm	mm
32	18,5	22	30	30	16	12	45,0	50,0	G1/8	28,5	71,0	M10x1,25	53,0
40	20,0	24	35	35	16	16	52,0	57,4	G1/4	33,0	76,5	M12x1,25	56,0
50	21,0	32	40	40	16	20	60,7	69,4	G1/4	33,5	80,0	M16x1,5	65,0
63	30,0	32	45	45	16	20	71,5	82,4	G3/8	39,5	96,0	M16x1,5	76,5
80	35,0	40	45	45	17	25	86,7	99,4	G3/8	39,5	110,0	M20x1,5	89,0
100	54,0	40	55	55	17	25	106,7	116,0	G1/2	44,5	132,0	M20x1,5	112,0
125	65,5	54	60	60	20	32	134,0	139,0	G1/2	51,0	144,5	M27x2	124,5

Cylinder bore mm	L8	L12	P	PL	PP	R	RT	SS	SW	T	TT	VA	VD	WH
mm	mm	mm	mm	mm	mm	mm	mm	mm	mm	mm	mm	mm	mm	mm
32	137	6,0	63,0	13,0	21,8	32,5	M6	4,0	10	4,5	4,5	3,5	4,5	15
40	149	6,5	67,5	14,0	21,9	38,0	M6	8,0	13	3,0	5,5	3,5	4,5	16
50	153	8,0	71,0	14,0	23,0	46,5	M8	4,0	17	5,5	7,5	3,5	5,0	17
63	178	8,0	87,0	16,4	27,4	56,5	M8	6,5	17	3,0	11,0	3,5	5,0	17
80	199	10,0	101,0	16,0	30,5	72,0	M10	0	22	6,0	15,0	3,5	4,0	20
100	226	14,0	122,0	18,0	35,8	89,0	M10	0	22	6,0	20,0	3,5	4,0	20
125	254	18,0	134,5	28,0	40,5	110,0	M12	0	27	6,0	17,5	5,5	6,0	27

S=Stroke

Tolerances

Cylinder bore mm	B	BA	L <sub>8</sub>	L <sub>9</sub>	R	Stroke tolerance up to stroke 500 mm	Stroke tolerance for stroke over 500 mm
mm	mm	mm	mm	mm	mm		
32	d11	d11	±0,4	±2	±0,5	+0,3/+2,0	+0,3/+3,0
40	d11	d11	±0,7	±2	±0,5	+0,3/+2,0	+0,3/+3,0
50	d11	d11	±0,7	±2	±0,6	+0,3/+2,0	+0,3/+3,0
63	d11	d11	±0,8	±2	±0,7	+0,3/+2,0	+0,3/+3,0
80	d11	d11	±0,8	±3	±0,7	+0,3/+2,0	+0,3/+3,0
100	d11	d11	±1,0	±3	±0,7	+0,3/+2,0	+0,3/+3,0
125	d11	d11	±1,0	±3	±1,1	+0,3/+2,0	+0,3/+3,0

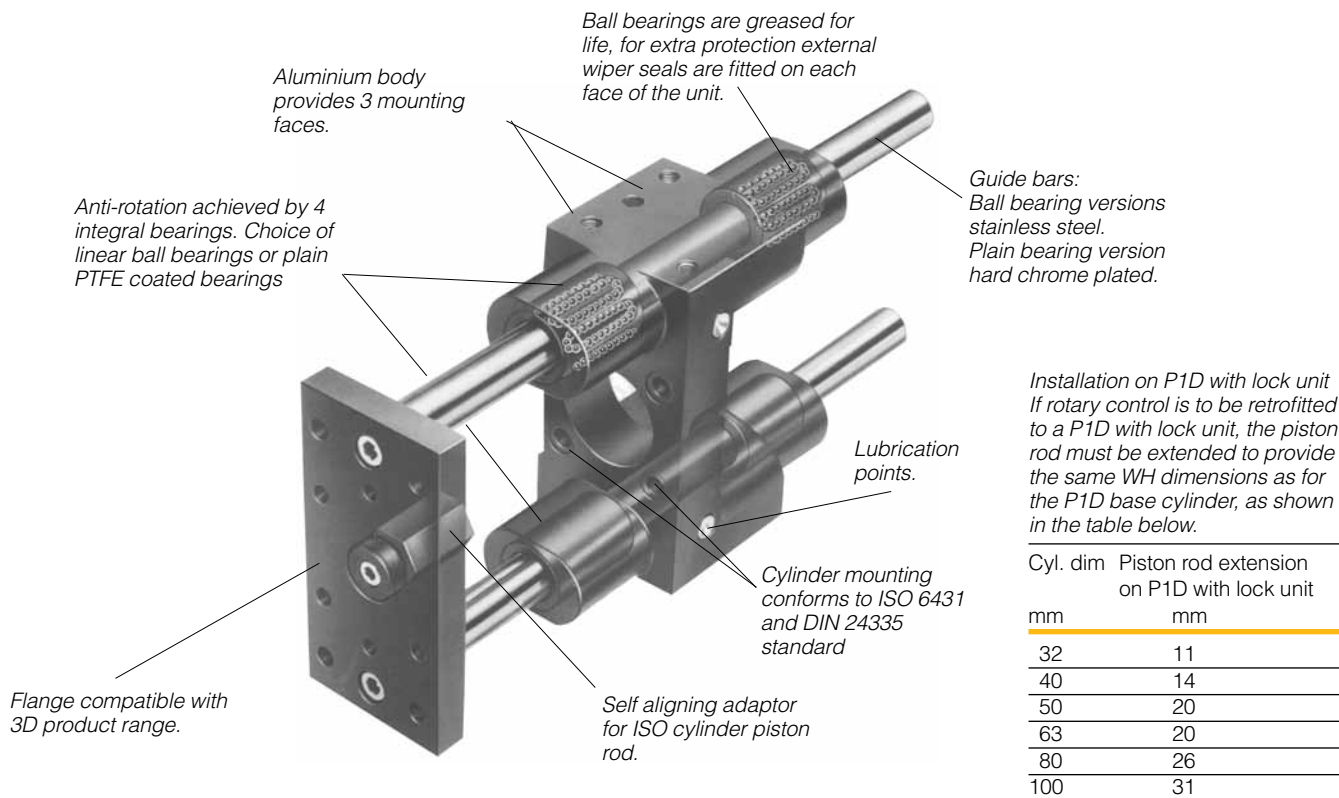

Installation on P1D with lock unit  
If rotary control is to be retrofitted to a P1D with lock unit, the piston rod must be extended to provide the same WH dimensions as for the P1D base cylinder, as shown in the table below.

Cyl. dim mm	Piston rod extension on P1D with lock unit mm
32	11
40	14
50	20
63	20
80	26
100	31

**P1D with rod guidance modules**

The P1D series cylinders can be equipped with an external guiding device to prevent the piston rod from turning. The factory fitted guide gives a guided piston movement and enables the cylinder to take up turning moments on the piston rod, as well as greater transverse forces. The rod guidance is available with plain bearings or linear ball bearings and with H or U style. The bracket, which has pre-drilled mounting holes, is connected to the piston rod by means of a flexofitting, which prevents the build-up of stresses in the cylinder. P1D cylinders with guiding device are available with bores from 32 to 100 mm, and standard stroke lengths from 25 to 250 mm. Special stroke lengths up to 500 mm can also be obtained. Factory-fitting of the guiding device can be specified according to the order key on page 30. Separate guiding device kits can be supplied on request according to the order key below.

**Technical data**

Load See diagram on page 36  
Working medium Dry, filtered compressed air  
Working temperature -20 °C to +80 °C

**Material specifications, guidance modules**

Body Anodised aluminium  
Guide bars, H style Stainless steel for ball bearing  
chrome plated for plain bearing  
Front plate Anodised aluminium  
Guide bars, U style Stainless steel  
Front plate Zinc-plated steel  
Bearings Plain bearings  
Linear ball bearings

Other data as standard cylinder.

**Order specifications for complete unit, please refer to pages 30 and 78**

**Order key for separate guidance module**

<b>P1E</b>		-	<b>4KRH</b>		-	<b>0100</b>	
<b>Cylinder version</b>		<b>Bore size mm</b>		<b>Guide module type</b>		<b>Stroke length (mm)</b>	
<b>E</b>	ISO 6431/ VDMA cylinders	<b>K</b>	32	<b>H</b>	H style, ball bearings	Same as for the cylinder e.g. <b>0100</b> = 100 mm.	
		<b>L</b>	40	<b>J</b>	H style, plain bearings		
		<b>M</b>	50	<b>K</b>	U style, plain bearings		
		<b>N</b>	63				
		<b>P</b>	80				
		<b>Q</b>	100				

Technical information 'H style'

Rod guide with ball bearings

Maximum load carried

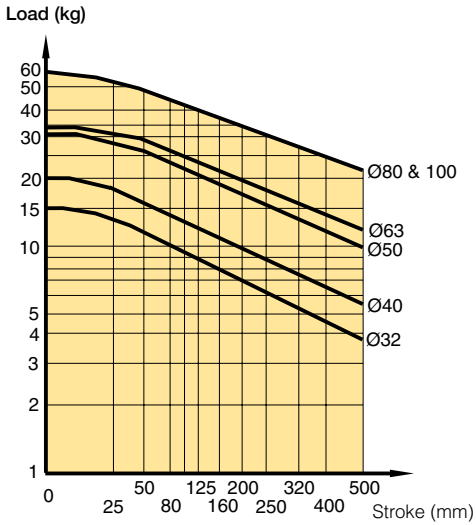

Graphs established at mid point of stroke

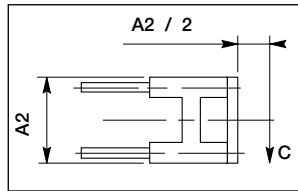

Rod guide with plain bearings

Maximum load carried

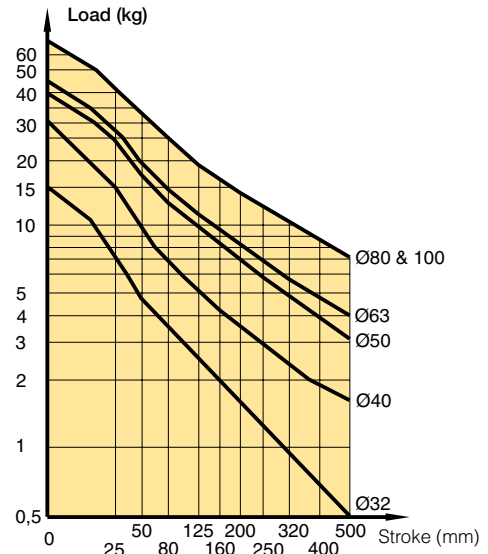

Maximum deflection/max load

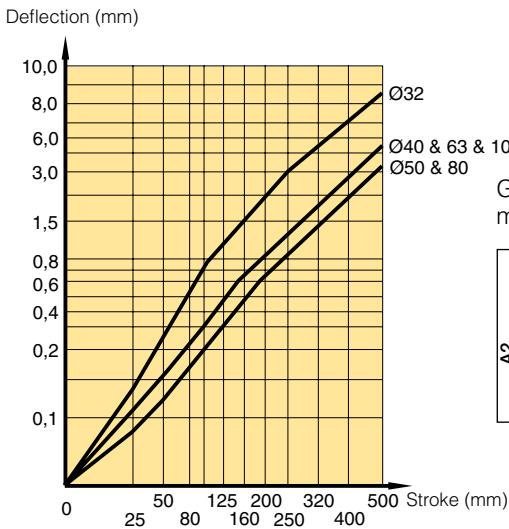

Graphs established at mid point of stroke

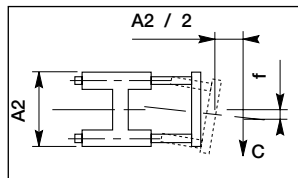

Maximum deflection/max load

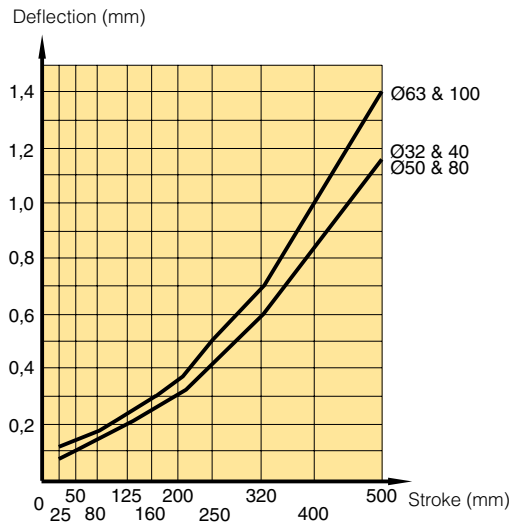

Maximum permissible torque (Nm)

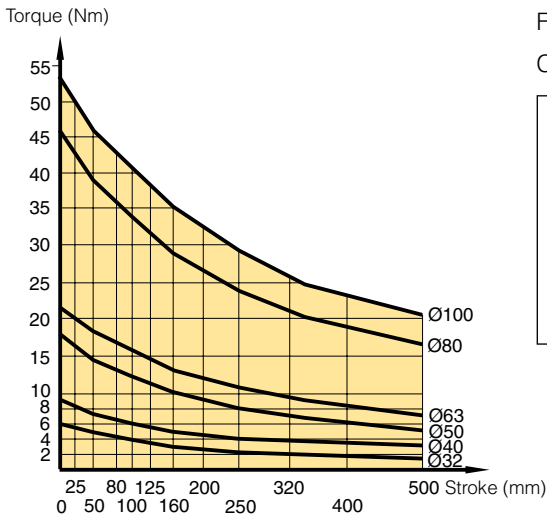

Formula:

$$C(Nm) = F(N) \times L(m)$$

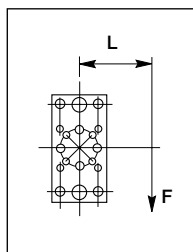

Maximum permissible torque (Nm)

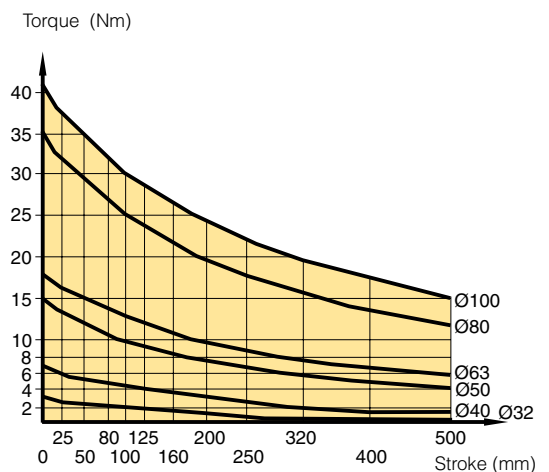

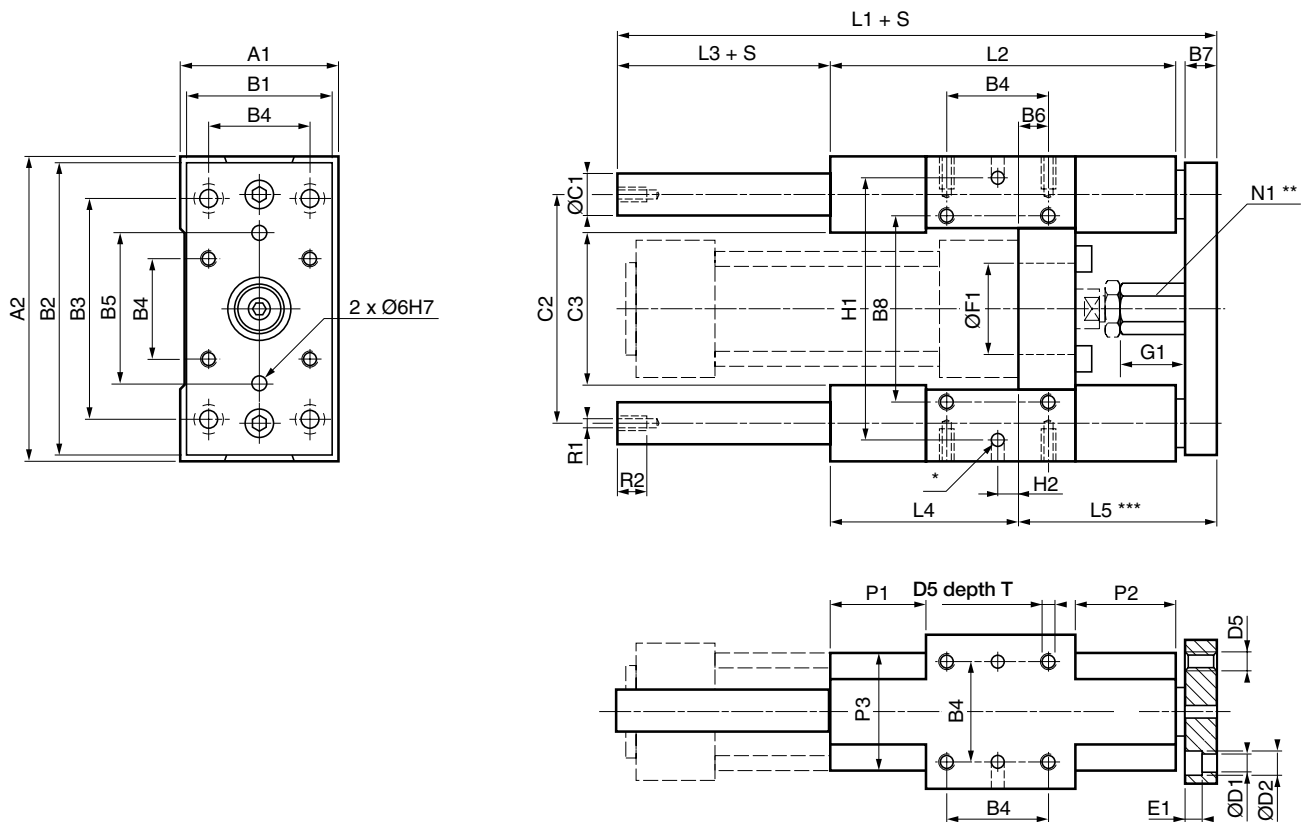

**Dimensions, H style guidance modules**

Cyl. bore mm	A <sub>1</sub> mm	A <sub>2</sub> mm	B <sub>1</sub> mm	B <sub>2</sub> mm	B <sub>3</sub> mm	B <sub>4</sub> mm	B <sub>5</sub> mm	B <sub>6</sub> mm	B <sub>7</sub> mm	B <sub>8</sub> mm	ØC <sub>1</sub> mm	C <sub>2</sub> mm	C <sub>3</sub> mm	ØD <sub>1</sub> mm	ØD <sub>2</sub> mm	D <sub>5</sub>
32	50	97	45	90	78	32,5	50	4,2	12	61	12	73,5	50	6,6	11	M6
40	58	115	54	110	84	38,0	54	11,0	12	69	16	86,5	58	6,6	11	M6
50	70	137	63	130	100	46,5	72	18,8	15	85	20	103,5	70	8,4	15	M8
63	85	152	80	145	105	56,5	82	15,0	15	100	20	118,5	83	8,4	15	M8
80	105	189	100	180	130	72,0	106	21,0	20	130	25	147,0	102	10,5	18	M10
100	130	213	120	200	150	89,0	131	24,5	20	150	25	171,5	125	10,5	18	M10

Cyl. bore mm	E <sub>1</sub> mm	ØF <sub>1</sub> <sup>+0,1/0</sup> mm	G <sub>1</sub> mm	L <sub>1</sub> mm	L <sub>2</sub> mm	L <sub>3</sub> mm	L <sub>4</sub> mm	L <sub>5</sub> mm	N <sub>1</sub> mm	P <sub>1</sub> <sup>±1</sup> mm	P <sub>2</sub> <sup>±1</sup> mm	P <sub>3</sub> mm	R <sub>1</sub> mm	R <sub>2</sub> mm	W mm
32	7	30	17	150	120	15	71	64	17	36	31	40	M6	11	5
40	7	35	24	170	130	25	71	74	17	36	36	44	M6	11	6
50	9	40	27	197	150	24	79	89	24	42	44	50	M8	16	8
63	9	45	27	222	180	24	109	89	24	58	44	60	M8	16	8
80	11	45	32	247	200	24	113	110	30	50	52	70	M10	16	10
100	11	55	32	267	220	24	128	115	30	49	51	70	M10	16	10

Cyl. bore mm	H <sub>1</sub> <sup>±0,05</sup> mm	H <sub>2</sub> mm	T mm	Weight at 0 mm stroke kg	Supplement weight per 10 mm stroke kg
32	81	11,7	12	0,970	0,018
40	99	8,0	12	1,550	0,032
50	119	4,2	16	2,560	0,050
63	132	13,0	16	3,570	0,050
80	166	15,0	20	6,530	0,078
100	190	20,5	20	8,760	0,078

S = Stroke length

\* 6 hole Ø6 H<sub>7</sub>, depth 10<sup>+1/0</sup>

\*\* Hexagon profile

\*\*\* Min adjustment=0, max.=W



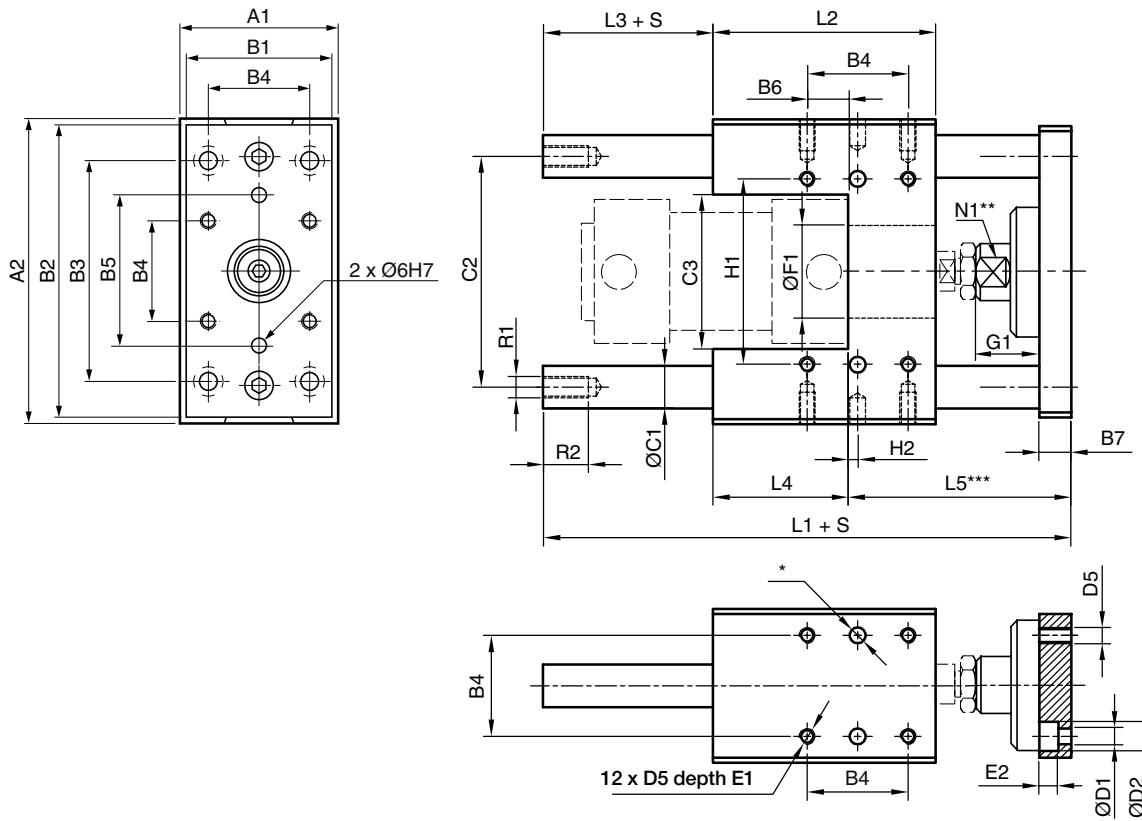

**Dimensions, U style guidance modules**

Cyl. bore. mm	A <sub>1</sub> mm	A <sub>2</sub> mm	B <sub>1</sub> mm	B <sub>2</sub> mm	B <sub>3</sub> mm	B <sub>4</sub> mm	B <sub>5</sub> mm	B <sub>6</sub> mm	B <sub>7</sub> mm	C <sub>1</sub> mm	C <sub>2</sub> mm	C <sub>3</sub> mm	D <sub>1</sub> mm	D <sub>2</sub> mm	D <sub>5</sub>
32	50	97	45	90	78	32,5	50	18,0	12	12	74	50	6,6	11	M6
40	58	115	54	110	84	38,0	54	15,5	12	16	87	58	6,6	11	M6
50	70	137	63	130	100	46,5	72	19,5	15	20	104	70	9,0	15	M8
63	85	152	80	145	105	56,5	82	29,5	15	20	119	85	9,0	15	M8
80	105	189	100	180	130	72,0	106	39,0	20	25	148	105	11,0	18	M10
100	130	213	120	200	150	89,0	131	53,5	20	25	172	130	11,0	18	M10

Cyl. bore. mm	E <sub>1</sub> mm	E <sub>2</sub> mm	Ø F <sub>1</sub> <sup>+0,1/0</sup> mm	G <sub>1</sub>	L <sub>1</sub> mm	L <sub>2</sub> mm	L <sub>3</sub> mm	L <sub>4</sub> mm	L <sub>5</sub> mm	N <sub>1</sub> mm	R <sub>1</sub> mm	R <sub>2</sub>	H <sub>1</sub> <sup>±0,05</sup> mm	H <sub>2</sub> mm	W <sup>***</sup> mm
32	10	6,5	30	30	133	72	14	44	75	13	M6	11	61	1,75	5
40	10	6,5	35	36	149	84	12	51	86	15	M8	12	69	3,50	5
50	13	9,0	40	42	175	100	12	60	103	22	M8	12	85	3,75	5
63	13	9,0	45	42	190	115	12	75	103	22	M8	12	100	1,25	5
80	16	11,0	45	49	238	162	0	112	126	27	M10	16	130	3,00	6
100	16	11,0	55	49	249	167	6	112	131	27	M10	16	150	8,50	6

Cyl. bore mm	Weight at 0 mm stroke kg	Supplement weight per 10 mm stroke kg
32	0,970	0,018
40	1,550	0,315
50	2,560	0,493
63	3,570	0,493
80	6,530	0,770
100	8,760	0,770

S = Stroke length

\* 6 hole Ø6<sup>H7</sup>, depth 10<sup>+1/0</sup>

\*\* Width of jaw

\*\*\* Min adjustment=0, max.=W

**Cylinder mountings**

Type	Description	Cyl. bore Ø mm	Weight kg	Order code
<b>Flange MF1/MF2</b>	Intended for fixed mounting of cylinder. Flange can be fitted to front or rear end cover of cylinder.  Materials Flange: Surface-treated steel, black Mounting screws acc. to DIN 6912: Zinc-plated steel 8.8  Supplied complete with mounting screws for attachment to cylinder.	32	0,23	<b>P1C-4KMB</b> <b>P1C-4LMB</b> <b>P1C-4MMB</b> <b>P1C-4NMB</b> <b>P1C-4PMB</b> <b>P1C-4QMB</b> <b>P1C-4RMB</b>
		40	0,28	
		50	0,53	
		63	0,71	
		80	1,59	
		100	2,19	
125	3,78			

**Flange MF1/MF2**



Materials  
Flange: Surface-treated steel, black  
Mounting screws acc. to DIN 6912: Zinc-plated steel 8.8

Supplied complete with mounting screws for attachment to cylinder.

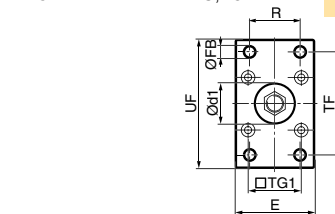

According to ISO MF1/MF2, VDMA 24 562, AFNOR

Cyl. bore mm	d1 mm	FB H13 mm	TG1 mm	E mm	R JS14 mm	MF JS14 mm	TF JS14 mm	UF mm	l1 -0,5 mm	W* mm	ZF* mm	ZB* mm
32	30	7	32,5	45	32	10	64	80	5,0	16	130	123,5
40	35	9	38,0	52	36	10	72	90	5,0	20	145	138,5
50	40	9	46,5	65	45	12	90	110	6,5	25	155	146,5
63	45	9	56,5	75	50	12	100	120	6,5	25	170	161,5
80	45	12	72,0	95	63	16	126	150	8,0	30	190	177,5
100	55	14	89,0	115	75	16	150	170	8,0	35	205	192,5
125	60	16	110,0	140	90	20	180	205	10,5	45	245	230,5

S = Stroke length \* Does not apply to cylinders with lock unit, please refer to page 48

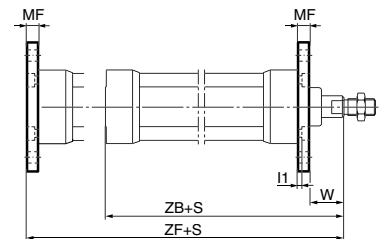

**Foot bracket MS1**



Intended for fixed mounting of cylinder. Foot bracket can be fitted to front and rear end covers of cylinder.

Materials  
Foot bracket: Surface-treated steel, black  
Mounting screws acc. to DIN 912: Zinc-plated steel 8.8

Supplied in pairs with mounting screws for attachment to cylinder.

32	0,06**	<b>P1C-4KMF</b> <b>P1C-4LMF</b> <b>P1C-4MMF</b> <b>P1C-4NMF</b> <b>P1C-4PMF</b> <b>P1C-4QMF</b> <b>P1C-4RMF</b>
40	0,08**	
50	0,16**	
63	0,25**	
80	0,50**	
100	0,85**	
125	1,48**	

\*\* Weight per item

According to ISO MS1, VDMA 24 562, AFNOR

Cyl. bore mm	AB H14 mm	TG1 mm	E mm	TR JS14 mm	AO mm	AU mm	AH JS15 mm	I7 mm	AT mm	I9 JS14 mm	SA* mm
32	7	32,5	45	32	10	24	32	30	4,5	17,0	142
40	9	38,0	52	36	8	28	36	30	4,5	18,5	161
50	9	46,5	65	45	13	32	45	36	5,5	25,0	170
63	9	56,5	75	50	13	32	50	35	5,5	27,5	185
80	12	72,0	95	63	14	41	63	49	6,5	40,5	210
100	14	89,0	115	75	15	41	71	54	6,5	43,5	220
125	16	110,0	140	90	22	45	90	71	8,0	60,0	250

S = Stroke length \* Does not apply to cylinders with lock unit, please refer to page 48

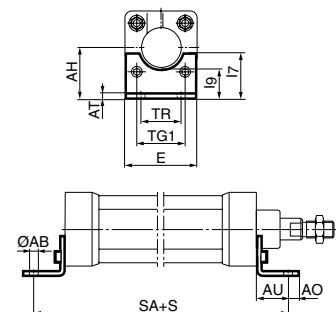

**Pivot bracket with rigid bearing**



Intended for flexible mounting of cylinder. The pivot bracket can be combined with clevis bracket MP2.

Materials  
Pivot bracket: Surface-treated aluminium, black  
Bearing: Sintered oil-bronze bushing

32	0,06	<b>P1C-4KMD</b> <b>P1C-4LMD</b> <b>P1C-4MMD</b> <b>P1C-4NMD</b> <b>P1C-4PMD</b> <b>P1C-4QMD</b> <b>P1C-4RMD</b>
40	0,08	
50	0,15	
63	0,20	
80	0,33	
100	0,49	
125	1,02	

According to CETOP RP 107 P, VDMA 24 562, AFNOR

Cyl. bore mm	CK H9 mm	S5 H13 mm	K1 JS14 mm	K2 mm	G1 JS14 mm	G2 JS14 mm	EM mm	G3 mm	CA JS15 mm	H6 mm	R1 mm
32	10	6,6	38	51	21	18	25,5	31	32	8	10,0
40	12	6,6	41	54	24	22	27,0	35	36	10	11,0
50	12	9,0	50	65	33	30	31,0	45	45	12	13,0
63	16	9,0	52	67	37	35	39,0	50	50	12	15,0
80	16	11,0	66	86	47	40	49,0	60	63	14	15,0
100	20	11,0	76	96	55	50	59,0	70	71	15	19,0
125	25	14,0	94	124	70	60	69,0	90	90	20	22,5

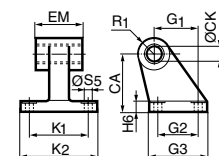



**Cylinder mountings**

Type	Description	Cyl. bore Ø mm	Weight kg	Order code
 <p><b>Swivel eye bracket</b></p>	Intended for use together with clevis bracket GA	32	0,08	<b>P1C-4KMSA</b> <b>P1C-4LMSA</b> <b>P1C-4MMSA</b> <b>P1C-4NMSA</b> <b>P1C-4PMSA</b> <b>P1C-4QMSA</b> <b>P1C-4RMSA</b>
	Material	40	0,11	
	Bracket: Surface-treated aluminium, black	50	0,20	
	Swivel bearing acc. to DIN 648K: Hardened steel	63	0,27	
		80	0,52	
		100	0,72	
	Supplied complete with mounting screws for attachment to cylinder.	125	1,53	

According to VDMA 24 562, AFNOR

Cyl. bore mm	E	B1	B2	EN	R1	R2	FL	I2	L	CN H7	XD*	Z
32	45	10,5	-	14	16	-	22	5,5	12	10	142	4°
40	52	12,0	-	16	18	-	25	5,5	15	12	160	4°
50	65	15,0	51	21	21	19	27	6,5	15	16	170	4°
63	75	15,0	-	21	23	-	32	6,5	20	16	190	4°
80	95	18,0	-	25	29	-	36	10,0	20	20	210	4°
100	115	18,0	-	25	31	-	41	10,0	25	20	230	4°
125	140	25,0	-	37	40	-	50	10,0	30	30	275	4°

S = Stroke length \* Does not apply to cylinders with lock unit, please refer to page 48

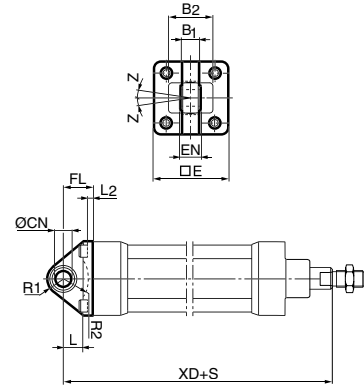

 <p><b>Clevis bracket MP2</b></p>	Intended for flexible mounting of cylinder. Clevis bracket MP2 can be combined with clevis bracket MP4.	32	0,08	<b>P1C-4KMT</b> <b>P1C-4LMT</b> <b>P1C-4MMT</b> <b>P1C-4NMT</b> <b>P1C-4PMT</b> <b>P1C-4QMT</b> <b>P1C-4RMT</b>
	Materials	40	0,11	
	Clevis bracket: Surface-treated aluminium, black	50	0,14	
	Pin: Surface hardened steel	63	0,29	
	Circlips according to DIN 471: Spring steel	80	0,36	
	Mounting screws acc. to DIN 912: Zinc-plated steel 8.8	100	0,64	
	Supplied complete with mounting screws for attachment to cylinder.	125	1,17	

According to ISO MP2, VDMA 24 562, AFNOR

Cyl. bore mm	C	E	UB h14	CB H14	FL ±0,2	L	I2	CD H9	MR	XD*
32	53	45	45	26	22	13	5,5	10	10	142
40	60	52	52	28	25	16	5,5	12	12	160
50	68	65	60	32	27	16	6,5	12	12	170
63	78	75	70	40	32	21	6,5	16	16	190
80	98	95	90	50	36	22	10,0	16	16	210
100	118	115	110	60	41	27	10,0	20	20	230
125	139	140	130	70	50	30	10,0	25	25	275

S = Stroke length \* Does not apply to cylinders with lock unit, please refer to page 48

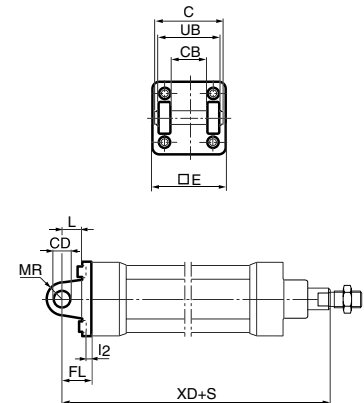

For mounting screws in stainless steel see page 65.

**Cylinder mountings**

Type	Description	Cyl. bore Ø mm	Weight kg	Order code
 <p><b>Clevis bracket MP4</b></p>	Intended for flexible mounting of cylinder. Clevis bracket MP4 can be combined with clevis bracket MP2.	32	0,09	<b>P1C-4KME</b> <b>P1C-4LME</b> <b>P1C-4MME</b> <b>P1C-4NME</b> <b>P1C-4PME</b> <b>P1C-4QME</b> <b>P1C-4RME</b>
		40	0,13	
	50	0,17		
	63	0,36		
	80	0,46		
	100	0,83		
	125	1,53		
Materials Clevis bracket: Surface-treated aluminium, black Mounting screws acc. to DIN 912: Zinc-plated steel 8.8				
Supplied complete with mounting screws for attachment to cylinder.				

According to ISO MP4, VDMA 24 562, AFNOR

Cyl. bore mm	E mm	EW mm	FL mm	L ±0,2 mm	I2 mm	CD mm	MR mm	XD* mm
32	45	26	22	13	5,5	10	10	142
40	52	28	25	16	5,5	12	12	160
50	65	32	27	16	6,5	12	12	170
63	75	40	32	21	6,5	16	16	190
80	95	50	36	22	10,0	16	16	210
100	115	60	41	27	10,0	20	20	230
125	140	70	50	30	10,0	25	25	275

S = Stroke length \* Does not apply to cylinders with lock unit, please refer to page 48

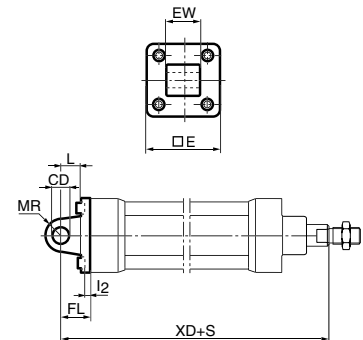

**Clevis bracket GA**



Intended for flexible mounting of cylinder. Clevis bracket GA can be combined with pivot bracket with swivel bearing, swivel eye bracket and swivel rod eye.

Materials  
 Clevis bracket: Surface-treated aluminium  
 Pin: Surface hardened steel  
 Locking pin: Spring steel  
 Circlips according to DIN 471: Spring steel  
 Mounting screws acc. to DIN 912: Zinc-plated steel 8.8

Supplied complete with mounting screws for attachment to cylinder.

According to VDMA 24 562, AFNOR

Cyl. bore mm	C mm	E mm	B2 d12 mm	B1 H14 mm	T mm	B3 mm	R2 mm	L1 mm	FL ±0,2 mm	I2 mm	L mm	CN F7 mm	R1 mm	XD* mm
32	41	45	34	14	3	3,3	17	11,5	22	5,5	12	10	11	142
40	48	52	40	16	4	4,3	20	12,0	25	5,5	15	12	13	160
50	54	65	45	21	4	4,3	22	14,0	27	6,5	17	16	18	170
63	60	75	51	21	4	4,3	25	14,0	32	6,5	20	16	18	190
80	75	95	65	25	4	4,3	30	16,0	36	10,0	20	20	22	210
100	85	115	75	25	4	4,3	32	16,0	41	10,0	25	20	22	230
125	110	140	97	37	6	6,3	42	24,0	50	10,0	30	30	30	275

S = Stroke length \* Does not apply to cylinders with lock unit, please refer to page 48

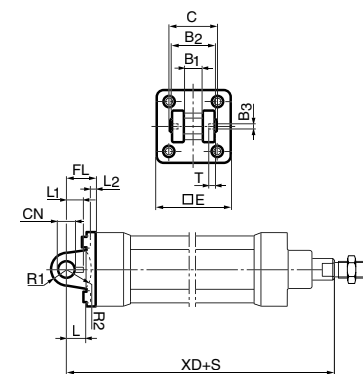

**Stainless steel Pin Set GA**

Materials  
 Pin: Stainless steel  
 Locking pin: Stainless steel  
 Circlips according to DIN 471: Stainless steel

32	0,05	<b>9301054311</b>
40	0,06	<b>9301054312</b>
50	0,07	<b>9301054313</b>
63	0,07	<b>9301054314</b>
80	0,17	<b>9301054315</b>
100	0,31	<b>9301054316</b>
125	0,54	<b>9301054317</b>

For mounting screws in stainless steel see page 65.

**Cylinder mountings**

Type	Description	Cyl. bore Ø mm	Weight kg	Order code
<b>Pivot bracket with swivel bearing</b> 	Intended for use together with clevis bracket GA.	32	0,18	<b>P1C-4KMA</b> <b>P1C-4LMA</b> <b>P1C-4MMA</b> <b>P1C-4NMA</b> <b>P1C-4PMA</b> <b>P1C-4QMA</b> <b>P1C-4RMA</b>
	Material	40	0,25	
	Pivot bracket: Surface-treated steel, black	50	0,47	
	Swivel bearing acc. to DIN 648K: Hardened steel	63	0,57	
		80	1,05	
		100	1,42	
		125	3,10	

According to VDMA 24 562, AFNOR

Cyl. bore mm	CN H7 mm	S5 H13 mm	K1 JS14 mm	K2 mm	EU mm	G1 JS14 mm	G2 JS14 mm	EN mm	G3 mm	CH JS15 mm	H6 mm	ER mm	Z mm
32	10	6,6	38	51	10,5	21	18	14	31	32	10	16	4°
40	12	6,6	41	54	12,0	24	22	16	35	36	10	18	4°
50	16	9,0	50	65	15,0	33	30	21	45	45	12	21	4°
63	16	9,0	52	67	15,0	37	35	21	50	50	12	23	4°
80	20	11,0	66	86	18,0	47	40	25	60	63	14	28	4°
100	20	11,0	76	96	18,0	55	50	25	70	71	15	30	4°
125	30	14,0	94	124	25,0	70	60	37	90	90	20	40	4°

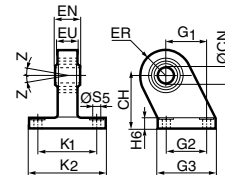

**Mounting kit**

	Mounting kit for back to back mounted cylinders, 3 and 4 position cylinders.	32	0,060	<b>P1E-6KB0</b> <b>P1E-6LB0</b> <b>P1E-6MB0</b> <b>P1E-6NB0</b> <b>P1E-6PB0</b> <b>P1E-6QB0</b>
	Material:	40	0,078	
	Mounting: Aluminium	50	0,162	
	Mounting screws: Zinc-plated steel 8.8	63	0,194	
		80	0,450	
		100	0,672	
		125	0,672	

Cyl. bore mm	E mm	TG mm	ØFB mm	MF mm	A mm	ØBA mm
32	50	32,5	6,5	5	16	30
40	60	38,0	6,5	5	16	35
50	66	46,5	8,5	6	20	40
63	80	56,5	8,5	6	20	45
80	100	72,0	10,5	8	25	45
100	118	89,0	10,5	8	25	55

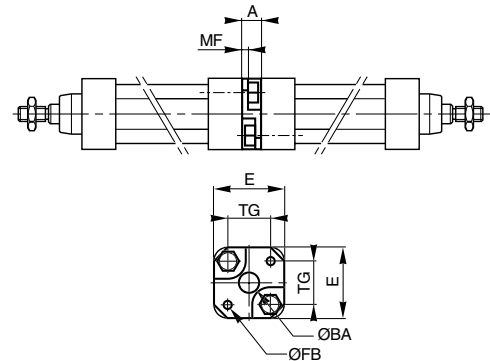

**Pivot bracket for MT4**

	Intended for use together with centre trunnion MT4.	32	0,04*	<b>9301054261</b> <b>9301054262</b> <b>9301054262</b> <b>9301054264</b> <b>9301054264</b> <b>9301054266</b> <b>9301054266</b>
	Material	40	0,07*	
	Pivot bracket: Surface-treated aluminium	50	0,07*	
	Bearing acc. to DIN 1850 C: Sintered oil-bronze bushing	63	0,12*	
	Supplied in pairs.	80	0,12*	
		100	0,21*	
		125	0,21*	

\* Weight per item.

According to ISO, VDMA 24 562, AFNOR

Cyl. bore mm	B1 mm	B2 mm	A mm	C mm	d1 mm	d2 H13 mm	H1 mm	H2 mm	fx45° min mm
32	46	18,0	32	10,5	12	6,6	30	15	1,0
40	55	21,0	36	12,0	16	9,0	36	18	1,6
50	55	21,0	36	12,0	16	9,0	36	18	1,6
63	65	23,0	42	13,0	20	11,0	40	20	1,6
80	65	23,0	42	13,0	20	11,0	40	20	1,6
100	75	28,5	50	16,0	25	14,0	50	25	2,0
125	75	28,5	50	16,0	25	14,0	50	25	2,0

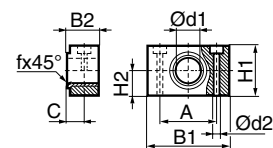

**Cylinder mountings**

Type	Description	Cyl. bore Ø mm	Weight kg	Order code
<b>Centre trunnion MT4 for P1D-S</b> 	Intended for articulated mounting of cylinder. This mounting is available for the P1D Standard and for the tie-rod design of P1D. The trunnion is factory-fitted in the centre of the cylinder or at an optional location specified by the XV-measure – see the order code key. Combined with pivot bracket for MT4. Material: Trunnion: zinc plated steel	32	0,13	<b>See order key on pages 31 and 80-82</b>
		40	0,31	
		50	0,37	
		63	0,69	
		80	0,89	
		100	1,58	
		125	2,60	

**Centre trunnion MT4 for P1D-T**



**Trunnion centred**

The centre trunnion for the P1D-S and P1D-T is ordered with letter D in position 17 (no dimension specified in positions 18-20). See the order code key at pages 31.

**Trunnion with optional location**

The centre trunnion for the P1D-S and P1D-T is ordered with letter G in position 17 and desired XV-measure (3-digit measure in mm) in positions 18-20. See the order code key at page 31.

**Trunnion loose**

P1D-S can also be ordered with the centre trunnion loosely fitted to the cylinder (not fixed in position). This allows the position to be established at the time of installation.

Ordered with letter G in position 17 and 000 in positions 18-20. Please refer to the order code key on page 31.

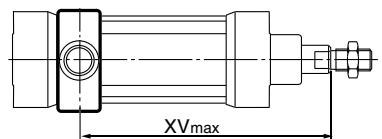
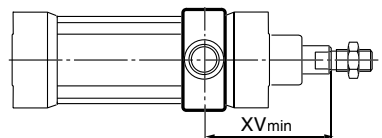
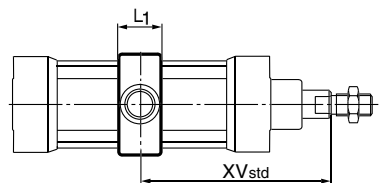
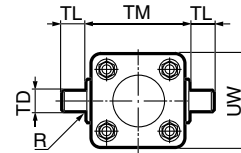

According to ISO MT4, VDMA 24 562, AFNOR

Cyl. bore mm	TM h14 mm	TL h14 mm	TD e9 mm	R mm	UW		L1		X1*	XV <sub>min</sub>			X2		
					P1D-S	P1D-T	P1D-S	P1D-T		P1D-S	P1D-T	P1D-L	P1D-S	P1D-T	P1D-L
32	50	12	12	1,0	52	46	18	15	73,0	89	62	121	57	84	88
40	63	16	16	1,6	59	59	20	20	82,5	95	73	125	70	92	99
50	75	16	16	1,6	71	69	20	20	90,0	113	81	140	67	99	93
63	90	20	20	1,6	84	84	26	25	97,5	118	89	155	78	106	114
80	110	20	20	1,6	105	102	26	25	110,0	132	98	177	88	122	132
100	132	25	25	2,0	129	125	32	30	120,0	140	111	197	100	129	156
125	160	25	25	2,0	159	155	33	32	145,0	168	132	224	122	158	177

XVstd = X1 + Stroke length/2, XVmax = X2 + Stroke length  
8

**Flange mounted trunnion**



Intended for articulated mounting of cylinder. This trunnion can be flange mounted on the front or rear end cover of all P1D cylinders. At your choice, you can order a complete cylinder with factory-fitted flange mounted trunnion – see the order code key at pages 31 and 80-82. Individual trunnions have order code as shown to the right.

Material:  
Trunnion: zinc plated steel  
Screws: zinc plated steel, 8.8

Delivered complete with mounting screws for attachment to the cylinder

According to ISO MT4, VDMA 24 562, AFNOR

Cyl. bore mm	TM h14 mm	TL h14 mm	TD e9 mm	R mm	UW mm	L1 mm	XV <sub>1</sub> * mm	X* mm	Y mm
32	50	12	12	1,0	46	14	19,5	126,5	11
40	63	16	16	1,6	59	19	21,0	144,0	14
50	75	16	16	1,6	69	19	28,0	152,0	20
63	90	20	20	1,6	84	24	25,5	169,5	20
80	110	20	20	1,6	102	24	34,5	185,5	26
100	132	25	25	2,0	125	29	37,0	203,0	31

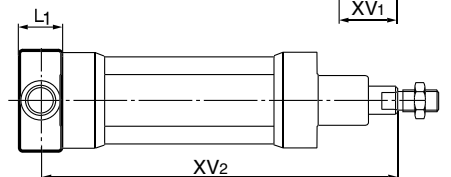
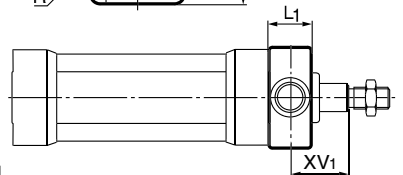
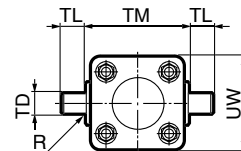

XV<sub>2</sub> = X + Stroke length \* Does not apply to cylinders with lock unit, please refer to page 48

To fit a flange mounted trunnion at the front end cover of a P1D cylinder with lock unit, the piston rod must be extended. This is in order to provide the same WH dimensions as for the P1D base cylinder with dimension Y.



**P1D-4KMYF**  
**P1D-4LMYF**  
**P1D-4MMYF**  
**P1D-4NMYF**  
**P1D-4PMYF**  
**P1D-4QMYF**



**Piston rod mountings**

Type	Description	Cyl. bore Ø mm	Weight kg	Order code
<b>Swivel rod eye</b> 	Swivel rod eye for articulated mounting of cylinder. Swivel rod eye can be combined with clevis bracket GA. Maintenance-free.  Materials Swivel rod eye: Zinc-plated steel Swivel bearing according to DIN 648K: Hardened steel	32	0,08	<b>P1C-4KRS</b> <b>P1C-4LRS</b> <b>P1C-4MRS</b> <b>P1C-4MRS</b> <b>P1C-4PRS</b> <b>P1C-4PRS</b> <b>P1C-4RRS</b>
		40	0,12	
		50	0,25	
		63	0,25	
		80	0,46	
		100	0,46	
<b>Stainless steel swivel rod eye</b> 	Stainless-steel swivel rod eye for articulated mounting of cylinder. Swivel rod eye can be combined with clevis bracket GA. Maintenance-free.  Materials Swivel rod eye: Stainless steel Swivel bearing according to DIN 648K: Stainless steel  Use stainless steel nut (see page 62) with stainless steel swivel rod eye.	32	0,08	<b>P1S-4JRT</b> <b>P1S-4LRT</b> <b>P1S-4MRT</b> <b>P1S-4MRT</b> <b>P1S-4PRT</b> <b>P1S-4PRT</b> <b>P1S-4RRT</b>
		40	0,12	
		50	0,25	
		63	0,25	
		80	0,46	
		100	0,46	
125	1,28			

According to ISO 8139

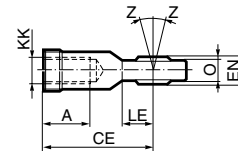
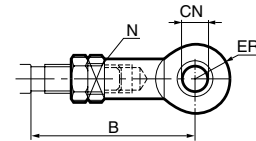
Cyl. bore mm	A mm	B min mm	B max mm	CE mm	CN H9 mm	EN h12 mm	ER mm	KK mm	LE min mm	N mm	O mm	Z mm
32	20	48,0	55	43	10	14	14	M10x1,25	15	17	10,5	12°
40	22	56,0	62	50	12	16	16	M12x1,25	17	19	12,0	12°
50	28	72,0	80	64	16	21	21	M16x1,5	22	22	15,0	15°
63	28	72,0	80	64	16	21	21	M16x1,5	22	22	15,0	15°
80	33	87,0	97	77	20	25	25	M20x1,5	26	32	18,0	15°
100	33	87,0	97	77	20	25	25	M20x1,5	26	32	18,0	15°
125	51	123,5	137	110	30	37	35	M27x2	36	41	25,0	15°



<b>Clevis</b> 	Clevis for articulated mounting of cylinder.  Material Clevis, clip: Galvanized steel Pin: Hardened steel	32	0,09	<b>P1C-4KRC</b> <b>P1C-4LRC</b> <b>P1C-4MRC</b> <b>P1C-4MRC</b> <b>P1C-4PRC</b> <b>P1C-4PRC</b> <b>P1C-4RRC</b>
		40	0,15	
		50	0,35	
		63	0,35	
		80	0,75	
		100	0,75	
<b>Stainless steel clevis</b> 	Stainless-steel clevis for articulated mounting of cylinder.  Material Clevis: Stainless steel Pin: Stainless steel Circlips according to DIN 471: Stainless steel  Use stainless steel nut (see page 62) with stainless steel swivel rod eye.	32	0,09	<b>P1S-4JRD</b> <b>P1S-4LRD</b> <b>P1S-4MRD</b> <b>P1S-4MRD</b> <b>P1S-4PRD</b> <b>P1S-4PRD</b> <b>P1S-4RRD</b>
		40	0,15	
		50	0,35	
		63	0,35	
		80	0,75	
		100	0,75	
125	2,10			

According to ISO 8140

Cyl. bore mm	A mm	B min mm	B max mm	CE mm	CK h11/E9 mm	CL mm	CM mm	ER mm	KK mm	LE mm	O mm
32	20	45,0	52	40	10	20	10	16	M10x1,25	20	28,0
40	24	54,0	60	48	12	24	12	19	M12x1,25	24	32,0
50	32	72,0	80	64	16	32	16	25	M16x1,5	32	41,5
63	32	72,0	80	64	16	32	16	25	M16x1,5	32	41,5
80	40	90,0	100	80	20	40	20	32	M20x1,5	40	50,0
100	40	90,0	100	80	20	40	20	32	M20x1,5	40	50,0
125	56	123,5	137	110	30	55	30	45	M27x2	54	72,0

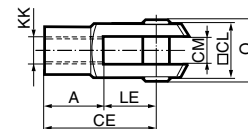
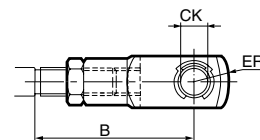





**Piston rod mountings**

Type	Description	Cyl. bore Ø mm	Weight kg	Order code
<b>Flexo coupling</b> 	Flexo coupling for articulated mounting of piston rod.	32	0,21	<b>P1C-4KRF</b> <b>P1C-4LRF</b> <b>P1C-4MRF</b> <b>P1C-4MRF</b> <b>P1C-4PRF</b> <b>P1C-4PRF</b> <b>P1C-4RRF</b>
	Flexo fitting is intended to take up axial angle errors within a range of ±4°.	40	0,22	
		50	0,67	
		63	0,67	
	Material	80	0,72	
	Flexo coupling, nut: Zinc-plated steel	100	0,72	
	125	1,80		

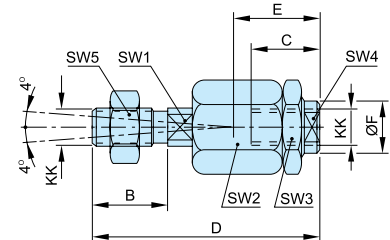
Supplied complete with galvanized adjustment nut.

Cyl. bore mm	KK mm	B mm	C mm	D mm	E mm	ØF mm	SW1 mm	SW2 mm	SW3 mm	SW4 mm	SW5 mm
32	M10x1.25	20	23	73	31	21	12	30	30	19	17
40	M12x1.25	24	23	77	31	21	12	30	30	19	19
50	M16x1.5	32	32	108	45	33.5	19	41	41	30	24
63	M16x1.5	32	32	108	45	33.5	19	41	41	30	24
80	M20x1.5	40	42	122	56	33.5	19	41	41	30	30
100	M20x1.5	40	42	122	56	33.5	19	41	41	30	30
125	M27x2	54	48	147	51	39	24	55	55	32	41



<b>Nut</b> 	Intended for fixed mounting of accessories to the piston rod.	32	0,007	<b>9128985601</b> <b>0261109910</b> <b>9128985603</b> <b>9128985603</b> <b>0261109911</b> <b>0261109911</b> <b>0261109912</b>
	Material: Zinc-plated steel	40	0,010	
	All P1D cylinders are delivered with a zinc-plated steel piston rod nut, except P1D Clean, which is delivered with a stainless steel piston rod nut instead.	50	0,021	
		63	0,021	
		80	0,040	
		100	0,040	
<b>Stainless steel nut</b> 	Intended for fixed mounting of accessories to the piston rod.	32	0,007	<b>9126725404</b> <b>9126725405</b> <b>9126725406</b> <b>9126725406</b> <b>0261109921</b> <b>0261109921</b> <b>0261109922</b>
	Material: Stainless steel A2	40	0,010	
	All P1D cylinders are delivered with a zinc-plated steel piston rod nut, except P1D Clean, which is delivered with a stainless steel piston rod nut instead.	50	0,021	
		63	0,021	
		80	0,040	
		100	0,040	
<b>Acid-proof nut</b> 	Intended for fixed mounting of accessories to the piston rod.	32	0,007	<b>0261109919</b> <b>0261109920</b> <b>0261109917</b> <b>0261109917</b> <b>0261109916</b> <b>0261109916</b> <b>0261109916</b>
	Material: Acid-proof steel A4	40	0,010	
	Cylinders with acid-proof piston rod are supplied with nut of acid-proof steel	50	0,021	
		63	0,021	
		80	0,040	
		100	0,040	
	125	0,100		

According to DIN 439 B

Cyl. bore mm	A mm	B mm	C
32	17	5,0	M10x1,25
40	19	6,0	M12x1,25
50	24	8,0	M16x1,5
63	24	8,0	M16x1,5
80	30	10,0	M20x1,5
100	30	10,0	M20x1,5
125	41	13,5	M27x2

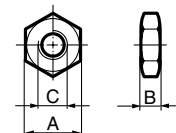



**Combinations**

Type	Description	Cyl. bore Ø mm	Weight kg	Order code			
<b>Clevis bracket MP4</b> 	<b>Clevis bracket MP2</b> In this combination the clevis bracket MP4 is attached to the cylinder.	32	0,17	<b>P1C-4KML</b> <b>P1C-4LML</b> <b>P1C-4MML</b> <b>P1C-4NML</b> <b>P1C-4PML</b> <b>P1C-4QML</b> <b>P1C-4RML</b>			
		40	0,24				
		50	0,31				
		63	0,65				
		80	0,82				
		100	1,47				
		125	2,70				
			Same as above but with screws and pin in stainless steel.		32	0,13	<b>P1C-4KMG</b> <b>P1C-4LMG</b> <b>P1C-4MMG</b> <b>P1C-4NMG</b> <b>P1C-4PMG</b> <b>P1C-4QMG</b> <b>P1C-4RMG</b>
		40	0,23				
		50	0,35				
		63	0,61				
		80	0,66				
100	1,53						
125	2,83						

Delivered as individual mountings, not mounted together, and complete with mounting screws for attachment to cylinder.

Cyl. bore mm	A	B	C	CD	d3	E	FL	L	TG1	XA*	XD*	Z
mm	mm	mm	mm	H9	H13	mm	±0,2	mm	mm	mm	mm	mm
32	9	44	53	10	6,6	45	22	13	32,5	164	142	112°
40	9	50	60	12	6,6	52	25	16	38,0	185	160	122°
50	11	54	68	12	9,0	65	27	16	46,5	197	170	94°
63	11	64	78	16	9,0	75	32	21	56,5	222	190	112°
80	14	72	98	16	11,0	95	36	22	72,0	246	210	82°
100	14	82	118	20	11,0	115	41	27	89,0	271	230	90°
125	20	100	139	25	13,5	140	50	30	110,0	325	275	94°

S = Stroke length \* Does not apply to cylinders with lock unit, please refer to page 48

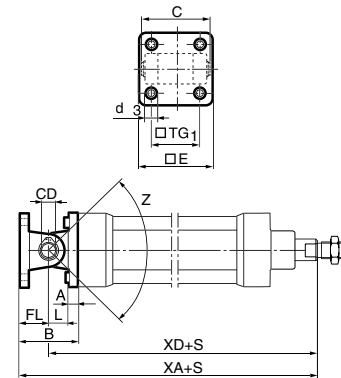

<b>Clevis bracket MP2</b> 	<b>Pivot bracket with rigid bearing</b> In this combination the clevis bracket MP2 is attached to the cylinder.	32	0,14	<b>P1C-4KMP</b> <b>P1C-4LMP</b> <b>P1C-4MMP</b> <b>P1C-4NMP</b> <b>P1C-4PMP</b> <b>P1C-4QMP</b> <b>P1C-4RMP</b>			
		40	0,19				
		50	0,29				
		63	0,49				
		80	0,69				
		100	1,13				
		125	2,83				
			Same as above but with screws and pin in stainless steel.		32	0,10	<b>P1C-4KMK</b> <b>P1C-4LMK</b> <b>P1C-4MMK</b> <b>P1C-4NMK</b> <b>P1C-4PMK</b> <b>P1C-4QMK</b> <b>P1C-4RMK</b>
		40	0,18				
		50	0,33				
		63	0,45				
		80	0,93				
100	1,19						
125	2,32						

Delivered as individual mountings, not mounted together, and complete with mounting screws for attachment to cylinder.

Cyl. bore mm	A	CA	D	E	G1	G2	G3	H6	k1	k2	S5	XA*	XD*	Z1	Z2
mm	mm	JS15	mm	mm	JS14	JS14	mm	mm	mm	JS14	H13	mm	mm	mm	mm
32	43	32	53	45	21	18	31	8	38	51	6,6	169,5	142	150°	18°
40	49	36	60	52	24	22	35	10	41	54	6,6	190,5	160	155°	18°
50	60	45	68	65	33	30	45	12	50	65	9,0	210,5	170	145°	18°
63	69	50	78	75	37	35	50	12	52	67	9,0	234,5	190	155°	20°
80	83	63	98	95	47	40	60	14	66	86	11,0	267,0	210	150°	20°
100	96	71	118	115	55	50	70	15	76	96	11,0	295,0	230	150°	15°
125	120	90	139	140	70	60	90	20	94	124	14,0	360,0	275	145°	18°

S = Stroke length \* Does not apply to cylinders with lock unit, please refer to page 48

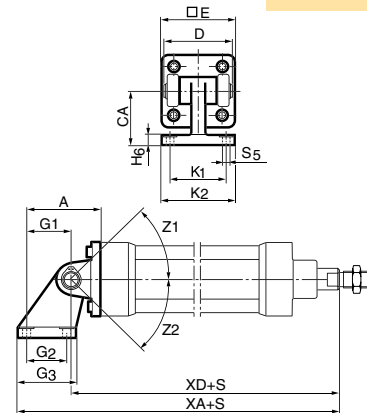



**Combinations**

Type	Description	Cyl. bore Ø mm	Weight kg	Order code
<b>Clevis bracket GA</b> 	<b>Pivot bracket with swivel bearing</b>  In this combination the clevis bracket GA is attached to the cylinder.  Delivered as individual mountings, not mounted together, and complete with mounting screws for attachment to cylinder.	32	0,40	<b>P1C-4KMQA</b> <b>P1C-4LMQA</b> <b>P1C-4MMQA</b> <b>P1C-4NMQA</b> <b>P1C-4PMQA</b> <b>P1C-4QMQA</b> <b>P1C-4RMQA</b>
		40	0,54	
		50	0,95	
		63	1,25	
		80	2,44	
		100	3,46	
		125	7,15	

Cyl. bore mm	CH mm	E mm	ER mm	G1 mm	G2 mm	G3 mm	H6 mm	k1 mm	k2 mm	I3 mm	S5 mm	XD* mm	Z1 °	Z2 °	Z3 °
	JS15			JS14	JS14			JS14			H13				
32	32	45	16	21	18	31	10	38	51	41	6,6	142	4°	130°	10°
40	36	52	18	24	22	35	10	41	54	48	6,6	160	4°	140°	15°
50	45	65	21	33	30	45	12	50	65	54	9,0	170	4°	130°	8°
63	50	75	23	37	35	50	12	52	67	60	9,0	190	4°	140°	20°
80	63	95	28	47	40	60	14	66	86	75	11,0	210	4°	125°	4°
100	71	115	30	55	50	70	15	76	96	85	11,0	230	4°	130°	4°
125	90	140	40	70	60	90	20	94	124	110	14,0	275	4°	120°	3°

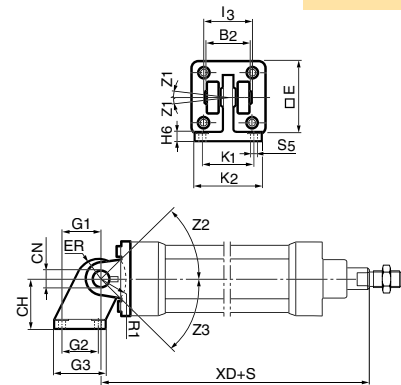
S = Stroke length \* Does not apply to cylinders with lock unit, please refer to page 48



Type	Description	Cyl. bore Ø mm	Weight kg	Order code
<b>Clevis bracket GA</b> 	<b>Swivel eye bracket</b>  In this combination the clevis bracket GA or the Swivel eye bracket can be attached to the cylinder.  Delivered as individual mountings, not mounted together, and complete with mounting screws for attachment to cylinder.	32	0,42	<b>P1C-4KMMA</b> <b>P1C-4LMMA</b> <b>P1C-4MMMA</b> <b>P1C-4NMMA</b> <b>P1C-4PMMA</b> <b>P1C-4QMQA</b> <b>P1C-4RMMA</b>
		40	0,59	
		50	0,98	
		63	1,38	
		80	2,59	
		100	3,64	
		125	5,85	

Cyl. bore mm	A mm	B mm	C mm	CN h9 mm	d3 H13 mm	E mm	FL ±0,2 mm	L mm	TG1 mm	XA* mm	XD* mm	Z1 °	Z2 °
32	10	44	41	10	6,6	45	22	12	32,5	164	142	4°	105°
40	10	50	48	12	6,6	52	25	15	38,0	185	160	4°	122°
50	10	54	54	16	9,0	65	27	17	46,5	197	170	4°	84°
63	12	64	60	16	9,0	75	32	20	56,5	222	190	4°	116°
80	16	72	75	20	11,0	95	36	20	72,0	246	210	4°	84°
100	16	82	85	20	11,0	115	41	25	89,0	271	230	4°	90°

S = Stroke length \* Does not apply to cylinders with lock unit, please refer to page 48

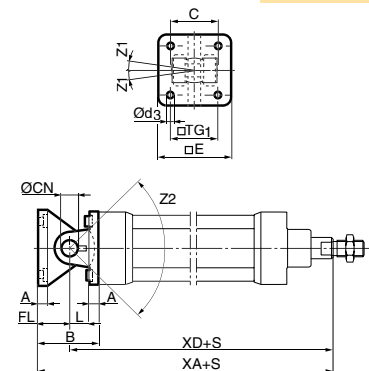

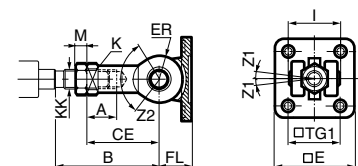

Type	Description	Cyl. bore Ø mm	Weight kg	Order code
<b>Swivel rod eye</b> 	<b>Clevis bracket GA</b>  In this combination the swivel rod eye is attached to the cylinder.  Same as above but with Swivel rod eye, screws and pin in stainless steel.	32	0,30	<b>P1C-4KRVA</b> <b>P1C-4LRVA</b> <b>P1C-4MRVA</b> <b>P1C-4NRVA</b> <b>P1C-4PRVA</b> <b>P1C-4QRVA</b> <b>P1C-4RRVA</b>
		40	0,41	
		50	0,73	
		63	0,93	
		80	1,85	
		100	2,50	
		125	5,33	

Cyl. bore mm	A mm	B <sub>min</sub> mm	B <sub>max</sub> mm	CE mm	E mm	ER mm	FL mm	k mm	kk mm	M mm	I mm	TG1 mm	Z1 °	Z2 °
32	20	48,0	55	43	45	14	22	17	M10x1,25	5,0	41	32,5	4°	208°
40	22	56,0	62	50	52	16	25	19	M12x1,25	6,0	48	38,0	4°	214°
50	28	72,0	80	64	65	21	27	22	M16x1,5	8,0	54	46,5	4°	206°
63	28	72,0	80	64	75	21	32	22	M16x1,5	8,0	60	56,5	4°	214°
80	33	87,0	97	77	95	25	36	32	M20x1,5	10,0	75	72,0	4°	198°
100	33	87,0	97	77	115	25	41	32	M20x1,5	10,0	85	89,0	4°	208°
125	51	123,5	137	110	140	35	50	41	M27x2	13,5	110	110,0	4°	200°



## Accessories

Type	Description	Cyl. bore Ø mm	Weight kg	Order code
<b>Stainless steel screw set MP2, MP4, MS1 and GA</b>  	Set of stainless steel screws for fitting clevis brackets MP2, MP4 and GA onto the cylinder. The screws have an internal hexagonal head and are used in special environments, e.g. the food industry, or where there are extra demands for protection against corrosion.  Material: According to DIN 912, Stainless steel, A2  4 pcs per pack.	32	0,02	<b>9301054321</b>
		40	0,02	<b>9301054321</b>
		50	0,05	<b>9301054322</b>
		63	0,05	<b>9301054322</b>
		80	0,09	<b>9301054323</b>
		100	0,09	<b>9301054323</b>
		125	0,15	<b>9301054324</b>
<b>Stainless steel screw set for MF1/MF2</b>  	Set of stainless steel screws for fitting flanges MF1/MF2 onto the cylinder. The screws have an internal hexagonal head and are used in special environments, e.g. the food industry, or where there are extra demands for protection against corrosion.  Material: According to DIN 6912, Stainless steel, A2  4 pcs per pack	32	0,02	<b>9301054331</b>
		40	0,02	<b>9301054331</b>
		50	0,04	<b>9301054332</b>
		63	0,04	<b>9301054332</b>
		80	0,07	<b>9301054333</b>
		100	0,07	<b>9301054333</b>
		125	0,12	<b>9301054334</b>
<b>Sealing plugs</b>  	Set of 4 threaded plugs to be fitted in unused end cover screws. A rubber gasket is supplied with every plug. The seal off function is equal to IP67. The plugs can be used for all P1D cylinders to avoid collecting dirt and fluids in the end cover screw recesses.  Material: Plug Polyamid PA Gasket Nitrile rubber  4 pcs per pack	32	0,01	<b>460104801</b>
		40	0,01	<b>460104801</b>
		50	0,02	<b>460104802</b>
		63	0,02	<b>460104802</b>
		80	0,02	<b>460104803</b>
		100	0,02	<b>460104803</b>
		125	0,03	<b>460104804</b>

**Combinations**

Type and description

**Cylinders complete with mountings, sensors, speed regulation, fittings etc.**

Order a complete working unit on a single order code instead of a lot of separate numbers. Save time in all phases, such as purchasing, goods reception and installation. A factory installed complete cylinder makes your work more efficient! Configure functions and equipment in the order key. See pages 78-79.



**3 and 4 position cylinders**

This type of cylinder function consists of two cylinders installed back to back. Two cylinders with the same stroke give a 3 position cylinder with a symmetrical centre position, whereas different strokes give a 4 position cylinder where the two central positions can be calculated from the different stroke lengths.

3 and 4 position cylinders can be ordered in two ways.



**Factory-fitted P1D-T**

Tie-rod P1D cylinders are completed at the factory and are joined together as one unit by special tie-rods, see position 9 in the order key. See pages 35 and 78-79.

**Installation kit for all designs**

There is an installation kit for cylinder bores 32 – 100 mm which makes it possible to join any two P1D cylinders together at any time, to make a 3 or 4 position cylinder.

Please refer to cylinder mountings, page 58.

Cylinder bore. mm	A, P1D-T mm	A, P1D-S mm
32	247	256
40	277	286
50	293	306
63	323	336
80	355	373
100	385	403
125	461	–

S=Stroke

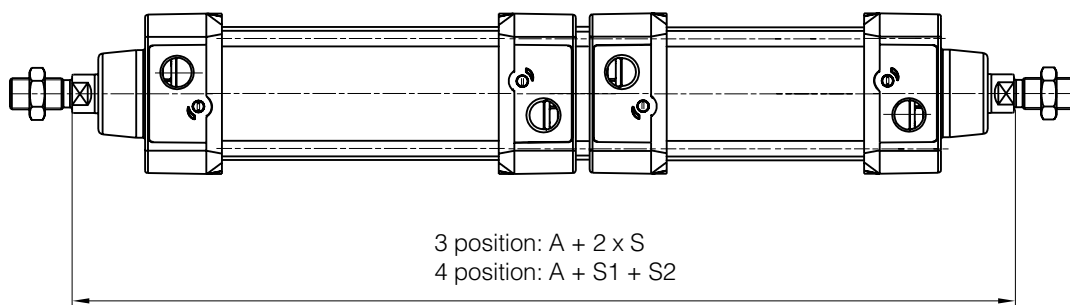

## Drop-in sensors

The P1D sensors can easily be installed from the side in the sensor groove, at any position along the piston stroke. The sensors are completely recessed and thus mechanically protected. Choose between electronic or reed sensors and several cable lengths and 8 mm and M12 connectors. The same standard sensors are used for all P1D versions.



## Electronic sensors

The electronic sensors are "Solid State", i.e. they have no moving parts at all. They are provided with short-circuit protection and transient protection as standard. The built-in electronics make the sensors suitable for applications with high on and off switching frequency, and where very long service life is required.

### Technical data

Design	GMR (Giant Magnetic Resistance) magneto-resistive function
Installation	From side, down into the sensor groove, so-called drop-in
Outputs	PNP, normally open (also available in NPN design, normally closed, on request)
Voltage range	10-30 VDC 10-18 V DC, ATEX sensor
Ripple	max 10%
Voltage drop	max 2,5 V
Load current	max 100 mA
Internal consumption	max 10 mA
Actuating distance	min 9 mm
Hysteresis	max 1,5 mm
Repeatability accuracy	max 0,2 mm
On/off switching frequency	max 5 kHz
On switching time	max 2 ms
Off switching time	max 2 ms
Encapsulation	IP 67 (EN 60529)
Temperature range	-25 °C to +75 °C -20 °C to +45 °C, ATEX sensor
Indication	LED, yellow
Material housing	PA 12
Material screw	Stainless steel
Cable	PVC or PUR 3x0.25 mm <sup>2</sup> see order code respectively

## Reed sensors

The sensors are based on proven reed switches, which offer reliable function in many applications. Simple installation, a protected position on the cylinder and clear LED indication are important advantages of this range of sensors.

### Technical data

Design	Reed element
Mounting	From side, down into the sensor groove, so-called drop-in
Output	Normally open , or normally closed
Voltage range	10-30 V AC/DC or 10-120 V AC/DC 24-230 V AC/DC
Load current	max 500 mA for 10-30 V or max 100 mA for 10-120 V max 30 mA for 24-230 V
Breaking power (resistive)	max 6 W/VA
Actuating distance	min 9 mm
Hysteresis	max 1,5 mm
Repeatability accuracy	0,2 mm
On/off switching frequency	max 400 Hz
On switching time	max 1,5 ms
Off switching time	max 0,5 ms
Encapsulation	IP 67 (EN 60529)
Temperature range	-25 °C to +75 °C
Indication	LED, yellow
Material housing	PA12
Material screw	Stainless steel
Cable	PVC or PUR 3x0.14 mm <sup>2</sup> see order code respectively

**Electronic sensors**

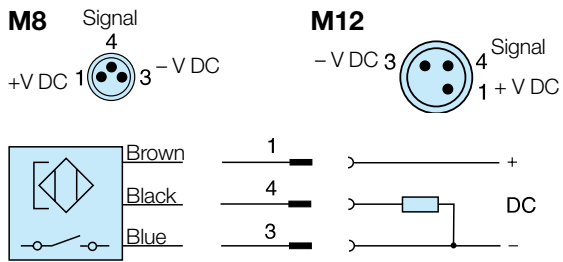

**Reed sensors**

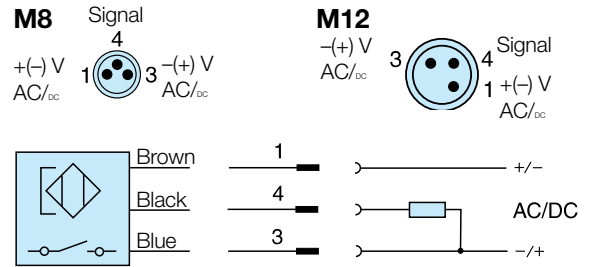

**P8S-GCFPX**

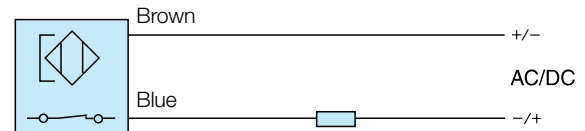

**P8S-GRFLX / P8S-GRFLX2**

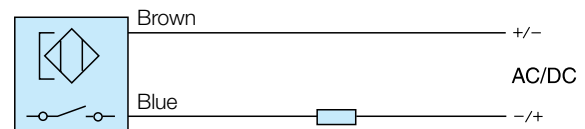

**Dimensions**

**Sensors**

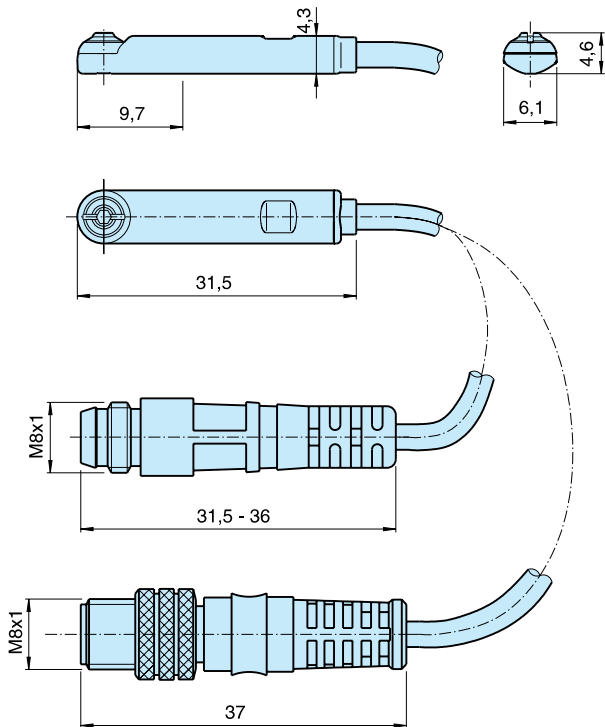

**Sensor Installation**

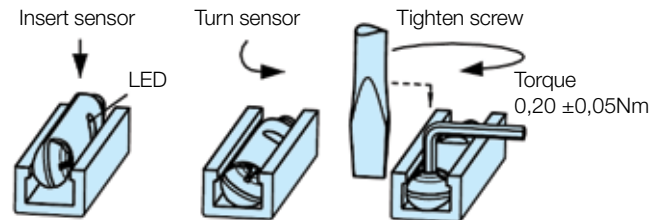



## Ordering data

Output/function	Cable/connector	Weight kg	Order code
<b>Electronic sensors , 10-30 V DC</b>			
PNP type, normally open	0,27 m PUR-cable and 8 mm snap-in male connector <sup>1)</sup>	0,007	<b>P8S-GPSHX</b>
PNP type, normally open	0,27 m PUR-cable and M12 screw male connector <sup>1)</sup>	0,015	<b>P8S-GPMHX</b>
PNP type, normally open	3 m PVC-cable without connector	0,030	<b>P8S-GPFLX</b>
PNP type, normally open	10 m PVC-cable without connector	0,110	<b>P8S-GPFTX</b>
<b>Reed sensors , 10-30 V AC/DC</b>			
Normally open	0,27 m PUR-cable and 8 mm snap-in male connector <sup>1)</sup>	0,007	<b>P8S-GSSHX</b>
Normally open	0,27 m PUR-cable and M12 screw male connector <sup>1)</sup>	0,015	<b>P8S-GSMHX</b>
Normally open	3 m PVC-cable without connector	0,030	<b>P8S-GSFLX</b>
Normally open	10 m PVC-cable without connector	0,110	<b>P8S-GSFTX</b>
Normally closed	5m PVC-cable without connector <sup>2)</sup>	0,050	<b>P8S-GCFPX</b>
<b>Reed sensors, 10-120 V AC/DC</b>			
Normally open	3 m PVC-cable without connector	0,030	<b>P8S-GRFLX</b>
<b>Reed sensorer, 24-230 V AC/DC</b>			
Normally open	3 m PVC-cable without connector	0,030	<b>P8S-GRFLX2</b>

1) Not in combination with P1D Clean (too short cable)

2) Without LED

## Adapter for tie-rod design

Description	Weight kg	Order code
Double jointed adapter for cylinder P1D-T cylinder bore Ø32 to Ø125 mm	0,07	<b>P8S-TMA0X</b>



## Connecting cables with one connector

The cables have an integral snap-in female connector.



Type of cable	Cable/connector	Weight kg	Order code kg
<b>Cables for sensors, complete with one female connector</b>			
Cable, Flex PVC	3 m, 8 mm Snap-in connector	0,07	<b>9126344341</b>
Cable, Flex PVC	10 m, 8 mm Snap-in connector	0,21	<b>9126344342</b>
Cable, Polyurethane	3 m, 8 mm Snap-in connector	0,01	<b>9126344345</b>
Cable, Polyurethane	10 m, 8 mm Snap-in connector	0,20	<b>9126344346</b>
Cable, Polyurethane	5 m, M12 screw connector	0,07	<b>9126344348</b>
Cable, Polyurethane	10 m, M12 screw connector	0,20	<b>9126344349</b>

## Male connectors for connecting cables

Cable connectors for producing your own connecting cables. The connectors can be quickly attached to the cable without special tools. Only the outer sheath of the cable is removed. The connectors are available for M8 and M12 screw connectors and meet protection class IP 65.



Connector	Weight kg	Order code
M8 screw connector	0,017	<b>P8CS0803J</b>
M12 screw connector	0,022	<b>P8CS1204J</b>

## Pneumatic cylinder sensor for P1D-T

An ideal solution where a direct pneumatic signal is wanted from a cylinder sensor to a pneumatic control system, for example. This could be a machine or device in which only compressed air is available, and an electricity supply to normal cylinder sensors would involve serious problems or considerable expense.

### Function:

Non-contacting sensing of a pneumatic cylinder, triggering an output signal (conn. 2) from the integrated 3/2 NC valve, which is activated by a magnetic field or iron core and has a return spring.

If more than one sensor is used with a cylinder there must be a distance of at least 20 mm between sensors to prevent them influencing each other.

To avoid interference, there must be a minimum spacing of 15 mm to steel details.

The outlet (conn. 3) must not be blocked or restricted as this can impair the function of the sensor.

The sensor is fastened to the cylinder using the special sensor fixing.

### Technical data:

Working pressure:	min 2 to max 6 bar
Temperature:	-15 to +60 °C
Air quality:	3.4.3 to ISO 8573-1 (must be oil free)
Function:	3/2 NC valve
Flow:	40 NI per minute
Connection:	for plastic pipe with 2,5-3 mm internal diameter
Activation distance:	for magnet: min 9 mm
Activation distance:	for Fe: approx. 2 mm
Repetition accuracy:	+/- 0.2 mm
Cylinder velocity:	max 1 m/s (depends on magnetic field, interference from steel in environment, signal length requirement from control system...)
Distance between sensors:	min 20 mm
Distance from sensor to steel details:	min 15 mm
Fixing:	with sensor fixing or with an M4 thread in case
Sensing:	non-contacting (also through a wall of non-magnetic material)

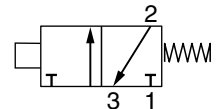

### Order codes

Name	Weight kg	Order code
Pneumatic sensor	0,02	<b>P8S-A34X</b>
Cylinder fixing	0,01	<b>P8S-AMA1</b>

### Cylinder fixing

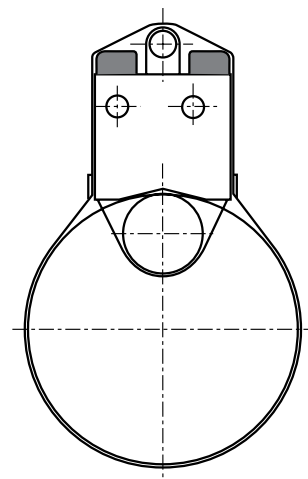



**P1D Seal kits**

- Complete seal kits consisting of:
- Piston seals
- Cushioning seals
- Piston rod bearing
- Combined piston rod seal and scraper ring
- O-rings
- Material specification, see page 19



**Order codes**

Cyl.bore mm	P1D cylinder version			
	Standard P1D-S, P1D-T, P1D-C, P1D-F	High Temp P1D-S	Low Temp P1D-S	Hydraulic P1D-S
32	<b>P1D-6KRN</b>	<b>P1D-6KRF</b>	<b>P1D-6KRL</b>	<b>P1D-6KRH</b>
40	<b>P1D-6LRN</b>	<b>P1D-6LRF</b>	<b>P1D-6LRL</b>	<b>P1D-6LRH</b>
50	<b>P1D-6MRN</b>	<b>P1D-6MRF</b>	<b>P1D-6MRL</b>	<b>P1D-6MRH</b>
63	<b>P1D-6NRN</b>	<b>P1D-6NRF</b>	<b>P1D-6NRL</b>	<b>P1D-6NRH</b>
80	<b>P1D-6PRN</b>	<b>P1D-6PRF</b>	<b>P1D-6PRL</b>	<b>P1D-6PRH</b>
100	<b>P1D-6QRN</b>	<b>P1D-6QRF</b>	<b>P1D-6QRL</b>	<b>P1D-6QRH</b>
125	<b>P1D-6RRN</b>	<b>P1D-6RRF</b>	<b>P1D-6RRL</b>	<b>P1D-6RRH</b>







Cyl.bore mm	P1D cylinder version			
	Standard temperature with FPM scraper ring  P1D-S, P1D-T, P1D-C, P1D-F	Standard temperature Dry piston rod with HDPE scraper ring  P1D-S, P1D-T, P1D-C, P1D-F	Standard temperature with metal scraper ring  P1D-S, P1D-T, P1D-C, P1D-F	Standard temperature with piston rod locking  P1D-L, P1D-D, P1D-4
32	<b>P1D-6KRV</b>	<b>P1D-6KRD</b>	<b>P1D-6KRQ</b>	<b>P1D-6KRNL</b>
40	<b>P1D-6LRV</b>	<b>P1D-6LRD</b>	<b>P1D-6LRQ</b>	<b>P1D-6LRNL</b>
50	<b>P1D-6MRV</b>	<b>P1D-6MRD</b>	<b>P1D-6MRQ</b>	<b>P1D-6MRNL</b>
63	<b>P1D-6NRV</b>	<b>P1D-6NRD</b>	<b>P1D-6NRQ</b>	<b>P1D-6NRNL</b>
80	<b>P1D-6PRV</b>	<b>P1D-6PRD</b>	<b>P1D-6PRQ</b>	<b>P1D-6PRNL</b>
100	<b>P1D-6QRV</b>	<b>P1D-6QRD</b>	<b>P1D-6QRQ</b>	<b>P1D-6QRNL</b>
125	<b>P1D-6RRV</b>	<b>P1D-6RRD</b>	<b>P1D-6RRQ</b>	<b>P1D-6RRNL</b>

Cyl.bore mm	P1D optional cylinder versions
	Through rod Standard temperature P1D-S, P1D-T, P1D-C, P1D-F
32	<b>P1D-6KRNf</b>
40	<b>P1D-6LRNf</b>
50	<b>P1D-6MRNf</b>
63	<b>P1D-6NRNf</b>
80	<b>P1D-6PRNf</b>
100	<b>P1D-6QRNf</b>
125	<b>P1D-6RRNf</b>







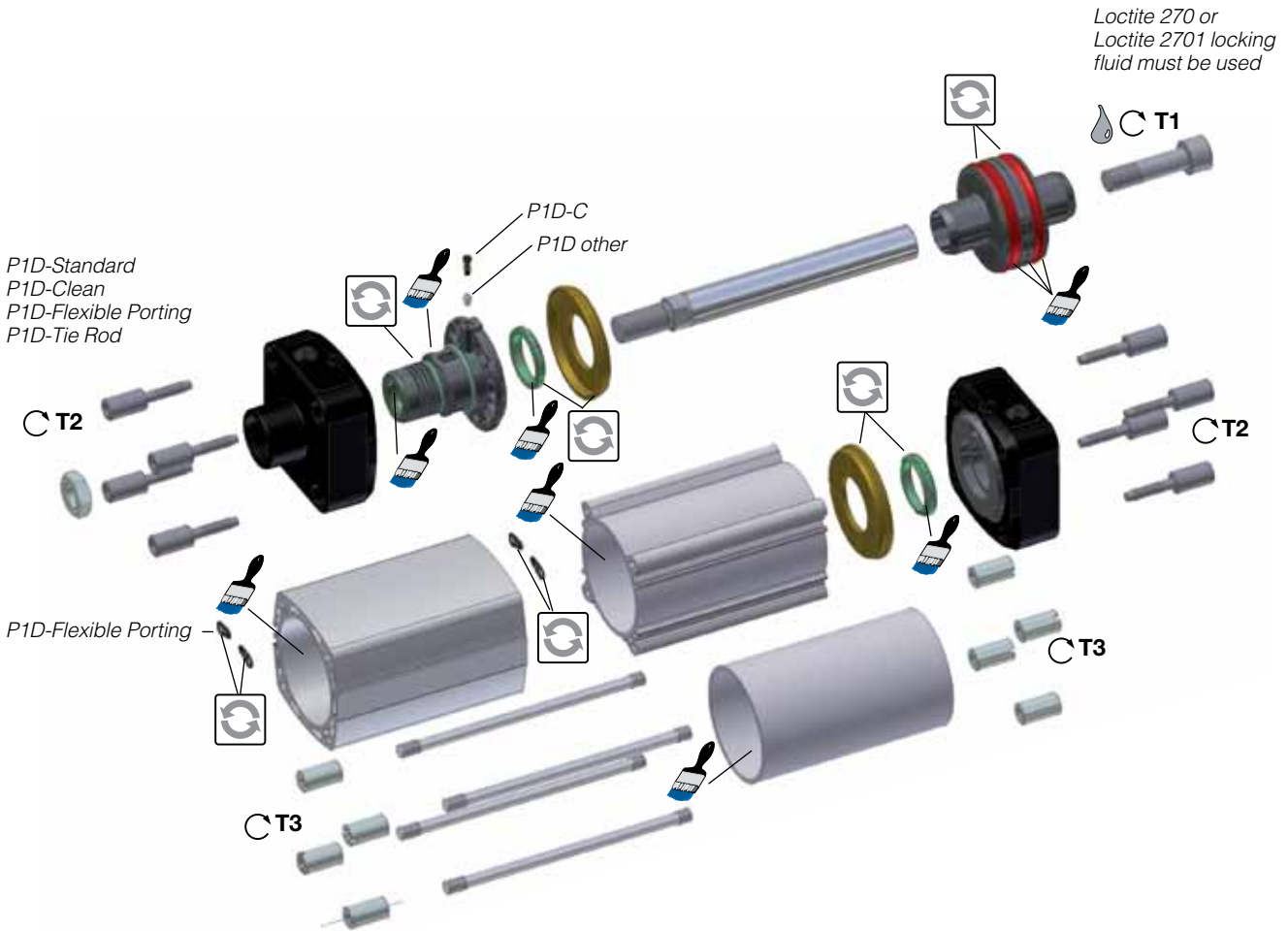

For other design variants with through rods, order double seal kits as above.  
Example: For a P1D-S Ø63 with through rod, high temperature version, order 2 x P1D-6NRF

Grease for P1D			
	Standard	30g	<b>9127394541</b>
	High temperature	30g	<b>9127394521</b>
	Low temperature	30g	<b>9127394541</b>







**Seal kit**

-  = Included in seal kit
-  = Screwdriver head
-  = Insexgrepp
-  = Tightening torque
-  = Lubricated with grease, see page 71.
-  = Locking fluid



Cyl.-dia mm	Plastic piston	Alu. piston	 NV mm	 T2 Nm	 NV mm	 T3 Nm	 NV mm	 NV mm
	T1  Nm	T1  Nm						
32	4,5	15	6	8	6	6	6	
40	11	30	8	8	6	6	6	
50	20	40	10	20	8	11	8	
63	20	40	10	20	8	11	8	
80	40	120	14	20	6	20		3x16
100	120	120	14	20	6	20		3x16
125	120	120	14	70	8	40		4x18

**Seal kit**

-  = Included in seal kit
-  = Screwdriver head
-  = Insexgrepp
-  = Tightening torque
-  = Lubricated with grease, see page 71.
-  = Locking fluid

*Loctite 270 or  
 Loctite 2701  
 locking fluid must  
 be used*

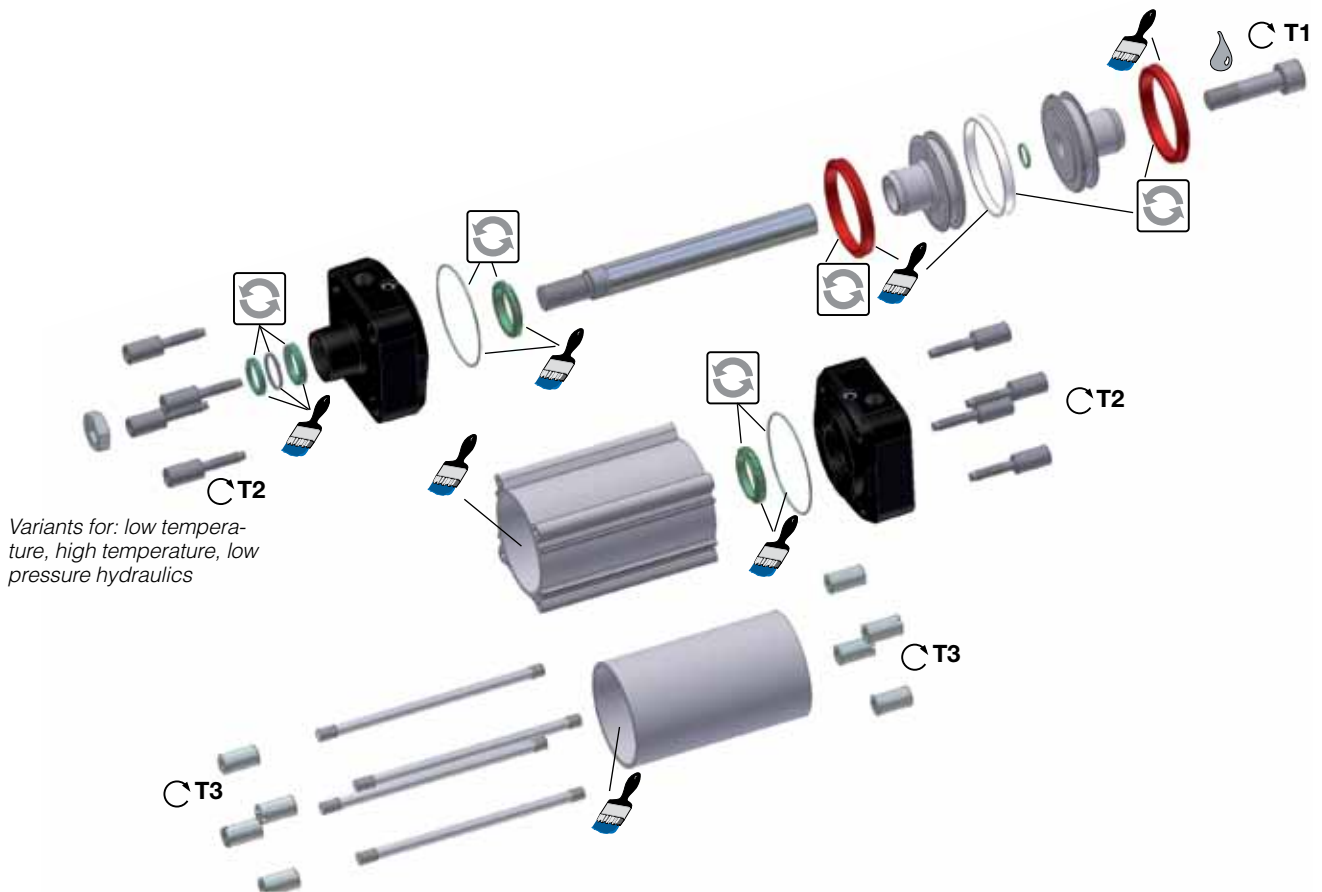

Cyl.-dia mm	Plastic piston T1	Alu. piston T1	NV mm	T2 Nm	NV mm	T3 Nm	NV mm	NV mm
	Nm	Nm						
32	4,5	15	6	8	6	6	6	
40	11	30	8	8	6	6	6	
50	20	40	10	20	8	11	8	
63	20	40	10	20	8	11	8	
80	40	120	14	20	6	20		3x16
100	120	120	14	20	6	20		3x16
125	120	120	14	70	8	40		4x18



Order key, spare parts

1	2	3	4	5	6	7	8	9	10	11	12	13	14	15
<b>P</b>	<b>1</b>	<b>D</b>	<b>-</b>	<b>8</b>	<b>0</b>	<b>3</b>	<b>2</b>	<b>D</b>	<b>G</b>	<b>-</b>	<b>0</b>	<b>1</b>	<b>0</b>	<b>0</b>

<b>8 Spare parts</b>
----------------------

Cylinder dia. mm
<b>032</b>
<b>040</b>
<b>050</b>
<b>063</b>
<b>080</b>
<b>100</b>
<b>125</b>

Piston rod
<b>D</b> Double-acting
<b>F</b> Piston rod locking, only chromium-plated rod
<b>G</b> Internal thread
<b>H</b> Through rod
<b>L</b> Through rod + piston rod locking
Cylinder barrel*
<b>A</b> Profile cylinder
<b>B</b> Cylindrical (for tie rod)
Tie rods
<b>T</b> Tie rods (order 4 for a cylinder)

\* Cylinder barrel for P1D Clean and P1D Flexport cannot be ordered with this order key. Contact customer service

Piston rod
<b>G</b> Stainless steel
<b>H</b> Hard-chromium plated
<b>J</b> Acid-resistant steel
<b>K</b> Chromium plated stainless
Cylinder barrel*
<b>A</b> Aluminium
Tie rods
<b>V</b> Stainless steel (order 4 for a cylinder)

Stroke** (mm) e.g. 0100 = 100 mm
Any stroke up to max. 2800 mm.

\*\* When ordering piston rods for cylinders with extended piston rod, add together the stroke and the extension in the order key.  
For example, a cylinder with stroke 100 mm and a piston rod extension of 25 mm is ordered with 0125 in the order number.

P1D with profile cylinder



P1D with tie rods

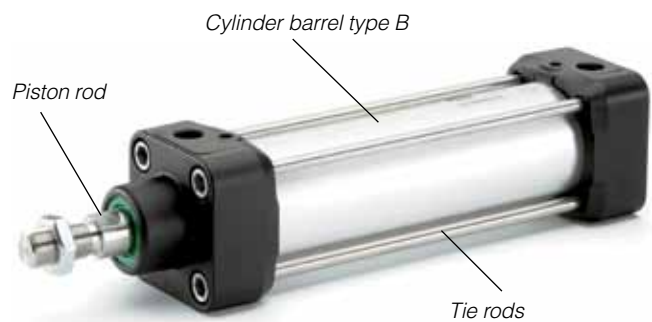



# There is a P1D cylinder for every application

## P1D Standard

The basic platform in the P1D family offers high performance, thanks to its very durable and user-friendly design.

1	2	3	4	5	6	7	8	9	10	11	12	13	14	15
P	1	D	-	S	0	3	2	M	S	-	0	1	0	0



## P1D Clean with integrated sensors

The obvious choice for stringent hygiene requirements, specially designed for demanding applications. The perfect fit for the food processing industry. Built-in sensors are selected in position 18.

1	2	3	4	5	6	7	8	9	10	11	12	13	14	15	16	17	18	19	20
P	1	D	-	C	0	5	0	M	S	-	0	3	2	0	N	N	C	N	N



## P1D Clean without sensor function

The clean cylinder for applications which do not require sensors. This is the only P1D Clean cylinder which is ordered with a 15-digit order code.

1	2	3	4	5	6	7	8	9	10	11	12	13	14	15
P	1	D	-	C	0	5	0	M	S	-	0	2	5	0



## Flexible Porting

The P1D Flexible Porting cylinder is available with both connections in one end of the end covers. This cylinder always has a 20-digit order code, where the position of the cylinder ports is defined in position 11 and the type of fitting and tube dimension is chosen in position 20.

1	2	3	4	5	6	7	8	9	10	11	12	13	14	15	16	17	18	19	20
P	1	D	-	F	0	5	0	M	S	B	0	3	2	0	N	N	N	N	0



**P1D Clean with Flexible Porting**

Combine P1D Clean with having both connections in one end, by using the Flexible Porting option.

1	2	3	4	5	6	7	8	9	10	11	12	13	14	15	16	17	18	19	20
P	1	D	-	C	0	5	0	M	S	B	0	3	2	0	N	N	C	N	8



**P1D Tie-Rod**

The same basic high technology design as all other P1D cylinder versions, but with a tie-rod design. Follows the same order code principles as our previous P1E range.

1	2	3	4	5	6	7	8	9	10	11	12	13	14	15
P	1	D	-	T	0	5	0	M	S	-	0	1	2	5



**P1D cylinder with piston rod locking**

The P1D cylinder is available in a version with piston rod locking, allowing the piston rod to be locked in any position. The lock unit, of the air/spring actuated type, is integrated in the front end piece of the cylinder.

**P1D Standard with piston rod locking**

1	2	3	4	5	6	7	8	9	10	11	12	13	14	15
P	1	D	-	L	0	5	0	M	C	-	0	2	5	0

**P1D Clean with piston rod locking**

1	2	3	4	5	6	7	8	9	10	11	12	13	14	15
P	1	D	-	D	0	5	0	M	C	-	0	2	5	0



**P1D complete working unit**

P1D Standard can be ordered with a factory-fitted valve and hosing. The valve series is the robust and compact Viking series, with product code P2L-A (for cylinder bores 32-63), P2L-B (for cylinder bores 80-100) and P2L-D (for cylinder bore 125).

1	2	3	4	5	6	7	8	9	10	11	12	13	14	15	16	17	18	19	20
P	1	D	-	V	0	5	0	M	S	1	0	3	2	0	N	N	N	N	H



15-digit order code

1	2	3	4	5	6	7	8	9	10	11	12	13	14	15
<b>P</b>	<b>1</b>	<b>D</b>	<b>-</b>	<b>S</b>	<b>0</b>	<b>4</b>	<b>0</b>	<b>M</b>	<b>S</b>	<b>-</b>	<b>0</b>	<b>3</b>	<b>2</b>	<b>0</b>

**5**

Cylinder version	
<b>S</b>	Standard
<b>C</b>	Clean <sup>2)</sup>
<b>F</b>	Flexible Porting
<b>T</b>	Tie-Rod
<b>V</b>	Standard with factory fitted valve
<b>L</b>	Standard with lock unit <sup>19)</sup>
<b>D</b>	Clean with lock unit <sup>19)</sup>
<b>4</b>	Standard with lock unit and factory fitted valve <sup>19)</sup>

**6-7-8**

Cylinder bore mm
<b>032</b>
<b>040</b>
<b>050</b>
<b>063</b>
<b>080</b>
<b>100</b>
<b>125</b>

**6** Rod extension only

Cylinder bore mm	
<b>K</b>	32
<b>L</b>	40
<b>M</b>	50
<b>N</b>	63
<b>P</b>	80
<b>Q</b>	100
<b>R</b>	125

**7-8**

Piston rod extension			
E.g. KR5 = Cylinder bore 32 mm with piston rod extension = 255 mm			
<b>01-99</b>	1-99	<b>N0-N9</b>	220-229
<b>A0-A9</b>	100-109	<b>P0-P9</b>	230-239
<b>B0-B9</b>	110-119	<b>Q0-Q9</b>	240-249
<b>C0-C9</b>	120-129	<b>R0-R9</b>	250-259
<b>D0-D9</b>	130-139	<b>S0-S9</b>	260-269
<b>E0-E9</b>	140-149	<b>T0-T9</b>	270-279
<b>F0-F9</b>	150-159	<b>U0-U9</b>	280-289
<b>G0-G9</b>	160-169	<b>V0-V9</b>	290-299
<b>H0-H9</b>	170-179	<b>W0-W9</b>	300-309
<b>J0-J9</b>	180-189	<b>X0-X9</b>	310-319
<b>K0-K9</b>	190-199	<b>Y0-Y9</b>	320-329
<b>L0-L9</b>	200-209	<b>Z0-Z9</b>	330-339
<b>M0-M9</b>	210-219		



Valid for P1D-S\*\*\*MS-\*\*\*\*, see ATEX information pages 22 - 25.

**12-13-14-15**

Stroke length see next page

**11**

Cylinder ports Flexible porting		Port location
Both front	Both rear	
<b>H<sup>3)</sup></b>	<b>J<sup>3)</sup></b>	G threads, BSPP (Ø 80-125)
<b>B<sup>4)</sup></b>	<b>C<sup>4)</sup></b>	Push-in, metric (Ø 32-80)
Cylinder ports Other		
— G threads, BSPP rear and front		
Factory fitted valve type		
<b>0</b>	air actuated	
<b>1</b>	Electrically actuated 24 V UC, LED+VDR (AC/DC Universal Current) Complete with rectifier	
<b>4</b>	Electrically actuated 24 V UC, LED+VDR med with 5 m integral cable (AC/DC Universal Current) Complete with rectifier	
<b>7</b>	Electrically actuated 24 V UC, LED+VDR med with 10 m integral cable (AC/DC Universal Current) Complete with rectifier	
<b>2</b>	115 V/50 Hz, 120 V/60 Hz, LED+VDR	
<b>3</b>	230 V/50 Hz, 240 V/60 Hz, LED+VDR	

**10**

Piston rod material				Seals	
Stainless steel	Chromium-plated steel	Acid-proof steel	Chrom.-pl. stainless steel		
<b>S</b>	<b>C</b>	<b>M</b>	<b>R</b>	Standard -20 °C to +80 °C.	

**9**

End cover screws						Function
Standard			Stainless steel <sup>22)</sup>			
Std scraper	HDPE scraper <sup>23)</sup>	FPM scraper <sup>24)</sup>	Std scraper	HDPE scraper <sup>23)</sup>	FPM scraper <sup>24)</sup>	
<b>M</b>	<b>D</b>	<b>V</b>	<b>A</b>	<b>H</b>	<b>W</b>	Double-acting
<b>F</b>	<b>E</b>	<b>B</b>	<b>G</b>	<b>Y</b>	<b>Z</b>	Double-acting through rod
<b>2</b>	<b>6</b>	<b>8</b>	-	-	-	3 and 4 position cylinders
<b>C</b>	<b>K</b>	<b>L</b>	-	-	-	Tandem

**16**

Factory-fitted piston rod mountings and sealing plugs		
No plugs <sup>6)</sup>	With plugs <sup>6)</sup>	
<b>S</b>	<b>A</b>	Swivel rod eye, zinc-plated steel
<b>T</b>	<b>1</b>	Swivel rod eye, stainless steel
<b>V</b>	<b>E</b>	Swivel rod eye, zinc-plated steel and clevis bracket GA
<b>W</b>	<b>2</b>	Swivel rod eye, stainless steel and clevis bracket GA
<b>C</b>	<b>B</b>	Clevis, zinc-plated steel
<b>D</b>	<b>3</b>	Clevis, stainless steel
<b>F</b>	<b>G</b>	Flexo coupling, zinc-plated steel
<b>X</b>	<b>P</b>	One additional piston rod nut <sup>9)</sup>
<b>Y</b>	<b>4</b>	Piston rod nut in stainless steel <sup>10)</sup>
<b>Z</b>	<b>5</b>	Piston rod nut in acid-proof steel
<b>6</b>	<b>7</b>	Without piston rod nut
<b>H</b>	<b>L</b>	Rod guidance, H, ball bearings <sup>18)</sup>
<b>J</b>	<b>M</b>	Rod guidance, H, plain bearings <sup>18)</sup>
<b>K</b>	<b>Q</b>	Rod guidance, U, plain bearings <sup>18)</sup>
<b>N</b>	<b>R</b>	None



20-digit order code

16 17 18 19 20

S	N	N	N <sup>1)</sup>	N
---	---	---	-----------------	---

17

Cylinder mountings	
90° 0°	90° = shaft square to, 0° = shaft in line with ports <sup>5)</sup>
<b>1 3</b>	Flange MF1/MF2 in front end
<b>B 4</b>	Flange MF1/MF2 in rear end
<b>2 K</b>	Flange MF1/MF2 in both ends
<b>F -</b>	Foot brackets MS1 (both ends)
<b>C U</b>	Clevis bracket GA
<b>E V</b>	Clevis bracket MP4
<b>S W</b>	Swivel eye bracket
<b>T Y</b>	Clevis bracket MP2
<b>L Z</b>	Clevis bracket MP2+MP4
<b>X 5</b>	Clevis bracket MP2+pivot bracket with rigid bearing
<b>Q 0</b>	Clevis bracket GA + pivot bracket with swivel bearing
<b>M A</b>	Clevis bracket GA +swivel eye bracket
<b>D 6</b>	Centre trunnion MT4, mid position <sup>6)</sup>
<b>G 7</b>	Trunnion MT4, optional pos. (XV-meas. pos 18-20) <sup>7)</sup>
<b>H P</b>	Trunnion flange in front end
<b>J 8</b>	Trunnion flange in rear end
<b>N</b>	None

18

Factory-fitted sensors			
Front end or left <sup>1)</sup>	Rear end or right <sup>1)</sup>	Front and rear end	Cable exit
<b>F</b>	<b>R</b>	-	2 sensors 24 VDC pnp, 3 m cable
<b>G</b>	<b>H</b>	-	2 sensors 24 VDC pnp, 10 m cable
<b>C</b>	<b>S</b>	-	2 sensors 24 VDC pnp, 8 mm connector, 1 m cable <sup>2)</sup>
<b>K</b>	<b>L</b>	-	2 sensors Reed type, 3 m cable
<b>T</b>	<b>V</b>	-	2 sensors Reed type, 10 m cable
<b>M</b>	<b>Q</b>	-	2 sensors Reed type, 8 mm connector, 1 m cable <sup>2)</sup>
-	-	<b>3</b>	3 sensors 24 VDC pnp, 8 mm connector, 1 m cable <sup>2)</sup>
-	-	<b>Z</b>	3 sensors Reed type, 8 mm connector, 1 m cable <sup>2)</sup>
-	-	<b>4</b>	4 sensors 24 VDC pnp, 8 mm connector, 1 m cable <sup>2)</sup>
-	-	<b>W</b>	4 sensors Reed type, 8 mm connector, 1 m cable <sup>2)</sup>
<b>6<sup>2)</sup></b>	<b>7<sup>3)</sup></b>	<b>8<sup>4)</sup></b>	No factory-fitted sensors P1D Clean
<b>N</b>	No sensors P1D (excl. P1D Clean)		

12-13-14-15

<b>Stroke (mm) e.g. 0100 = 100 mm</b>
Optional stroke lengths up to 2800 mm. Standard strokes see table page 18

20

Speed controls or fittings for tube dimension	Valve function
<b>Speed controls<sup>17)</sup>, Series PTF4PB<sup>16)</sup></b>	<b>Air actuated</b>
<b>X</b> in both ends for tube 4 mm <sup>15)</sup>	<b>A</b> Air-Air, 5/2
<b>Y</b> in both ends for tube 6 mm <sup>15)</sup>	<b>B</b> Air-Spring, 5/2
<b>Z</b> in both ends for tube 8 mm <sup>15)</sup>	<b>C</b> Air-Air, 5/3, closed centre position
<b>P</b> in both ends for tube 10 mm <sup>15)</sup>	<b>D</b> Air-Air, 5/3, vented centre
<b>R</b> in both ends for tube 12 mm <sup>15)</sup>	<b>E</b> Air-Air, 5/3, pressurised centre
<b>Push-in fitting, elbow type for:</b>	<b>Electrically actuated internal supply</b>
<b>4</b> Tube dimension 4 mm <sup>15)</sup>	<b>F</b> Elec-Elec, 5/2
<b>6</b> Tube dimension 6 mm <sup>15)</sup>	<b>H</b> Elec-Spring, 5/2
<b>8</b> Tube dimension 8 mm <sup>15)</sup>	<b>K</b> Spring-Elec, 5/2 <sup>20)</sup>
<b>0</b> Tube dimension 10 mm <sup>15)</sup>	<b>M</b> Elec-Elec, 5/3, closed centre position
<b>2</b> Tube dimension 12 mm <sup>15)</sup>	<b>Q</b> Elec-Elec, 5/3, vented centre
<b>Push-in fitting, straight type for:</b>	<b>S</b> Elec-Elec, 5/3, pressurised centre
<b>1</b> Tube dimension 4 mm <sup>15)</sup>	<b>Electrically actuated external supply</b>
<b>3</b> Tube dimension 6 mm <sup>15)</sup>	<b>G</b> Elec-Elec, 5/2
<b>5</b> Tube dimension 8 mm <sup>15)</sup>	<b>J</b> Elec-Spring, 5/2
<b>7</b> Tube dimension 10 mm <sup>15)</sup>	<b>L</b> Spring-Elec, 5/2 <sup>20)</sup>
<b>9</b> Tube dimension 12 mm <sup>15)</sup>	
<b>N</b> None	

19

Piston rod thread	
<b>N</b>	According to ISO-standard <sup>1)</sup>
<b>6</b>	Internal piston rod thread

17-18-19-20 4-position cylinders only

<b>Stroke (mm) e.g. 0100 = 100 mm</b>
The longest stroke in a 4 position cylinder. (Total stroke length up to max 2800 mm, see ordering example on page 36)

1-24) Information notes see page 80



**Information notes**

- 1) Code N for piston rod thread according to the ISO-standard. Other threads on request.
- 2) P1D Clean without sensor function, see page 41.
- 3) Only for P1D-F bore 80-125 mm. Select optional fittings in position 20, see page 42.
- 4) Only for P1D-F (Flexible Porting) bore 32-63 mm. Select fittings in position 20, see page 42.
- 5) Shaft or pivots square to or in line with the cylinder ports.
- 6) For versions P1D-S and P1D-T.
- 7) Only for P1D-T and P1D-S, XV-measure (from the piston rod thread according to ISO to the centre of the pivots) stated in mm in positions 18-20 (max 999).
- 8) Valid only for cylinders with factory-fitted cylinder mountings. P1D Clean cylinders are always delivered with 4 sealing plugs.
- 9) P1D cylinders are always delivered with one piston rod nut in zinc-plated steel, except P1D Clean which is delivered with the piston rod nut in stainless steel. Codes X and P mean that the cylinder is delivered with one additional nut of the same type.
- 10) The piston rod nut in zinc-plated steel is replaced by a nut in stainless steel (P1D Clean is always delivered with one piston rod nut in stainless steel).
- 11) Left and right valid for P1D Standard and P1D Tie-Rod seen from behind with the ports on top. The sensors can only be mounted on the left for P1D Flexible Porting.
- 12) No factory-fitted sensors, but prepared for cable exit in the front end (max. 2 sensors).
- 13) No factory-fitted sensors, but prepared for cable exit in the rear end (max. 2 sensors).
- 14) No factory-fitted sensors, but prepared for cable exit in both ends (max. 4 sensors).
- 15) To choose speed control and fittings, please refer to page 33 for P1D Standard and page 42 for P1D Flexible Porting.
- 16) P1D Clean cylinders have factory installed nickel plated versions of the PTF series.
- 17) Not available with P1D Flexible Porting bore 32-63 mm.
- 18) Valid for bore 32-100 mm.
- 19) Only for piston rod material type C and R.
- 20) Piston in extended position with unactuated valve.
- 21) The standard cable length is 0.277 m. However, P1D Clean is supplied with 1 m cable length.
- 22) If stainless steel end cover screws are selected, the piston rod nuts are also supplied in stainless steel.
- 23) For operation with dry piston rod. Intended for variants P1D-S, P1D-C, P1D-F, P1D-T and P1D-V
- 24) FPM scraper should be chosen for higher chemical resistance on standard temperature versions only.

**Air Reservoirs**

The Air Reservoir is produced by a cylinder tube and two standard rear end covers. The reservoir is kept together with standard end cover screws and sealed with standard static end cover seals. It's available in two versions, one with foot bracket and one without.

**Material specification**

Body extrusion: Natural colour, anodised aluminium  
 End covers: Black anodised aluminium  
 End cover screws: Zinc plated steel 8.8.  
 Seals: PUR

**Operation data**

Working pressure: Max 10 bar,  
 Working Temperature: Max 80°C

**Important**

Pressure Equipment Directive.  
 According (PED) to the directive 97/23/EC, for uncertified pressure vessels: Max Working pressure x Volume maximized to 50 Bar x Litre, i.e. max 10 bar and 5 litres volume.  
 In accordance we therefore maximized the volume to max 5 litres

**Order codes**

Volume cm <sup>3</sup>	Without foot bracket.	With foot bracket
75	<b>P1DVS032MA-0050</b>	<b>P1DVS032MB-0050</b>
280	<b>P1DVS050MA-0100</b>	<b>P1DVS050MB-0100</b>
480	<b>P1DVS050MA-0200</b>	<b>P1DVS050MB-0200</b>
1030	<b>P1DVS080MA-0160</b>	<b>P1DVS080MB-0160</b>
1870	<b>P1DVS080MA-0320</b>	<b>P1DVS080MB-0320</b>
3090	<b>P1DVS125MA-0200</b>	<b>P1DVS125MB-0200</b>
4680	<b>P1DVS125MA-0320</b>	<b>P1DVS125MB-0320</b>



**Using of Air Reservoirs**

Air reservoirs are used, e.g. together with throttle valves to achieve a timer function in a pneumatic system. The delay of time will be varies by changing the throttle valve and by the size of air reservoir. With a well functional throttle valve and a suitable air reservoir it would be possible to achieve a accuracy of ± 5%.. The reservoir is also used to equal pressure various into the system and to handling short extreme air consumptions without functional disorders. The air reservoirs could also be used together with check valve in order to retain a pressure which is essential, for example safety reasons.

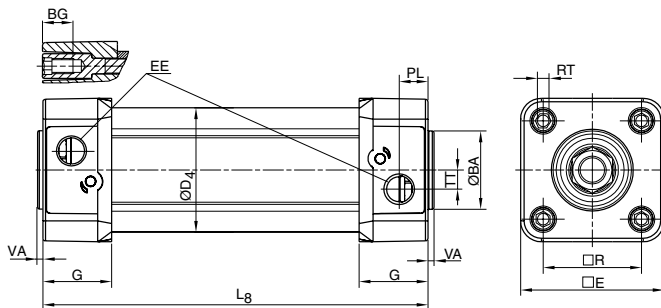

**Dimensions**

Order codes	BA	BG	D4	E	EE	G	L8	PL	R	RT	TT	VA
	mm	mm	mm	mm	mm	mm	mm	mm	mm		mm	mm
P1DVS032MA-0050	30	16	45,0	50,0	G1/8	28,5	144	13,0	32,5	M6	4,5	3,5
P1DVS050MA-0100	40	16	60,7	69,4	G1/4	33,5	206	14,0	46,5	M8	7,5	3,5
P1DVS050MA-0200	40	16	60,7	69,4	G1/4	33,5	306	14,0	46,5	M8	7,5	3,5
P1DVS080MA-0160	45	17	86,7	99,4	G3/8	39,5	288	16,0	72,0	M10	15,0	3,5
P1DVS080MA-0320	45	17	86,7	99,4	G3/8	39,5	458	16,0	72,0	M10	15,0	3,5
P1DVS125MA-0200	60	20	134,0	139,0	G1/2	51,0	360	28,0	110,0	M12	17,5	5,5
P1DVS125MA-0320	60	20	134,0	139,0	G1/2	51,0	480	28,0	110,0	M12	17,5	5,5

Order codes	AB	TG1	E	TR	AO	AU	AH	I7	AT	I9	SA
	mm	mm	mm	mm	mm	mm	mm	mm	mm	mm	mm
P1DVS032MB-0050	7	32,5	45	32	10	24	32	30	4,5	17,0	192
P1DVS050MB-0100	9	46,5	65	45	13	32	45	36	5,5	25,0	270
P1DVS050MB-0200	9	46,5	65	45	13	32	45	36	5,5	25,0	370
P1DVS080MB-0160	12	72,0	95	63	14	41	63	49	6,5	40,5	370
P1DVS080MB-0320	12	72,0	95	63	14	41	63	49	6,5	40,5	530
P1DVS125MB-0200	16	110,0	140	90	22	45	90	71	8,0	60,0	450
P1DVS125MB-0320	16	110,0	140	90	22	45	90	71	8,0	60,0	570

